



OPERATOR'S MANUAL

ECR235E

English

Volvo Construction Equipment  
Building Tomorrow



# OPERATOR'S MANUAL

ECR235E





**⚠ WARNING:** Breathing diesel engine exhaust exposes you to chemicals known to the State of California to cause cancer and birth defects or other reproductive harm.

- Always start and operate the engine in a well-ventilated area.
- If in an enclosed area, vent the exhaust to the outside.
- Do not modify or tamper with the exhaust system.
- Do not idle the engine except as necessary.

For more information go to [www.P65warnings.ca.gov/diesel](http://www.P65warnings.ca.gov/diesel).

**⚠ ADVERTENCIA:** Respirar los gases del escape de motores a diésel le expone a químicos conocidos por el Estado de California como causantes de cáncer y defectos de nacimiento u otros daños reproductivos.

- Siempre encienda y opere el motor en un área bien ventilada.
- Si es en un área cerrada, ventile el orificio del escape hacia el exterior.
- No modifique ni altere el sistema de escape.
- No encienda el motor, excepto cuando sea necesario.

Para mayor información visite [www.P65warnings.ca.gov/diesel](http://www.P65warnings.ca.gov/diesel).

**⚠ WARNING:** Operating, servicing and maintaining a passenger vehicle or offroad vehicle can expose you to chemicals including engine exhaust, carbon monoxide, phthalates, and lead, which are known to the State of California to cause cancer and birth defects or other reproductive harm. To minimize exposure, avoid breathing exhaust, do not idle the engine except as necessary, service your vehicle in a well-ventilated area and wear gloves or wash your hands frequently when servicing your vehicle. For more information go to [www.P65Warnings.ca.gov/passenger-vehicle](http://www.P65Warnings.ca.gov/passenger-vehicle).

**⚠ ADVERTENCIA:** Operar, dar servicio y mantenimiento a un vehículo de pasajeros o vehículo todo terreno puede exponerle a químicos incluyendo gases del escape, monóxido de carbono, ftalatos y plomo, los cuales son conocidos por el Estado de California como causantes de cáncer y defectos de nacimiento u otros daños reproductivos. Para minimizar la exposición, evite respirar los gases del escape, no encienda el motor excepto si es necesario, dé servicio a su vehículo en un área bien ventilada y utilice guantes o lave sus manos frecuentemente cuando dé servicio a su vehículo. Para mayor información visite [www.P65Warnings.ca.gov/passenger-vehicle](http://www.P65Warnings.ca.gov/passenger-vehicle).



## ECR235E L

### Foreword

This operator's manual is intended as a guide for the correct use and maintenance of the machine. Read this manual carefully before you start and move the machine or before you carry out any preventive maintenance.

Keep this manual in the lockable storage compartment so that it is always available for easy reference. Replace it immediately if it is lost.

The operator's manual describes the applications for which the machine was primarily designed. It has been written to be valid on all markets. Therefore, please ignore any sections which do not relate to your machine or to the work that you do with your machine.

**NOTE!**

If the manual covers more than one machine, the information relates to all machines unless otherwise specified.

When designing this machine, much time has been invested in achieving the best possible efficiency and safety. But accidents do happen, and most of them can be attributed to human error. A safety-conscious person and a well-maintained machine make up a reliable, powerful, and profitable combination. **Therefore, read the safety instructions and follow them.**

We constantly strive to develop and improve the efficiency of our products by making changes to their design. We reserve the right to make design modifications to the products even after they have been delivered. Also, we reserve the right to change data and equipment, as well as the service and maintenance instructions, without prior notice.

### OPERATOR'S MANUAL

Table of contents

Presentation

Instrument panels

Other controls

Operating instructions

Operating techniques

 Safety when servicing

Maintenance

Specifications

Alphabetical index

## Foreword

## 2

---

**Safety regulations**

The machine operator is responsible for being aware of and complying with the relevant, legally prescribed, national and regional safety instructions. The safety instructions in this operator's manual are applicable only in cases where no legislated safety instructions are in force.

** DANGER**

The safety symbol combined with this signal word indicates a hazardous situation which, if not avoided, ***will result in death or serious injury***. Danger is limited to the most extreme situations.

** WARNING**

The safety symbol combined with this signal word indicates a hazardous situation which, if not avoided, could result in ***death or serious injury***.

** CAUTION**

The safety symbol combined with this signal word indicates a hazardous situation which, if not avoided, could result in ***moderate or minor injury***.

**NOTICE**

Indicates a potentially hazardous situation which may result in machine damage.

**NOTE!**

Used in order to refer to installation, operating, or maintenance information which is important but not danger-related.

**Get to know the capacity and limits of your machine!**



## Identification numbers

Make a note below of the identification numbers of the machine and its components. Always use this information when contacting the manufacturer and when ordering spare parts.

<b>Manufacturer:</b>	Volvo Group Korea Co., Ltd. Seongsan-gu, Changwon-si, Gyeongsangnam-do, Korea 51710
Machine PIN (Serial number)	
Engine	
Main pump	
Swing motor	
Track motor	
Main control valve	

Please send any comments about the Operator's Manual to [om@volvo.com](mailto:om@volvo.com).



A series of horizontal dotted lines for writing, spanning the width of the page.



## Table of contents

<b>Foreword</b> .....	<b>1</b>
Identification numbers .....	3
<b>Presentation</b> .....	<b>9</b>
Machine view .....	19
CE-marking, EMC-directive .....	20
Communication equipment, installation .....	23
Safety components .....	24
Product plates .....	25
Information and warning decals .....	27
<b>Instrument panels</b> .....	<b>35</b>
Instrument panel, left .....	36
Instrument panel, front .....	38
Display unit .....	44
Instrument panel, right .....	80
Instrument panel, rear .....	94
<b>Other controls</b> .....	<b>95</b>
Controls .....	96
Cab .....	107
Control lockout system .....	111
Operator comfort .....	112
<b>Operating instructions</b> .....	<b>160</b>
Safety rules when operating .....	166
Measures before operating .....	171
Starting engine .....	172
Hydraulic system, warming up .....	177
Operating .....	179
Exhaust aftertreatment system .....	180
Stopping .....	192
Parking .....	193
Retrieving and towing .....	195
Transporting machine .....	197



Table of contents

---

<b>Operating techniques .....</b>	<b>202</b>
Whole-body vibrations .....	203
Rules for digging .....	205
Working within dangerous areas .....	208
Attachments .....	219
Attachments, connecting and disconnecting .....	221
Buckets .....	237
Hammer .....	239
Working with long range attachments .....	245
Hose rupture valves .....	246
Selecting track shoes .....	248
Lifting objects .....	250
Signalling diagram .....	256
<b>Safety when servicing .....</b>	<b>259</b>
Service position .....	260
Before service, read .....	261
Entering, leaving and climbing the machine	267
Fire prevention .....	268
Handling hazardous materials .....	271
Handling line, tubes and hoses .....	276
<b>Maintenance .....</b>	<b>277</b>
Lubrication and service chart .....	279
Maintenance service, every 10 hours .....	287
Maintenance service, every 50 hours .....	289
Maintenance service, every 250 hours .....	296
Maintenance service, every 500 hours .....	300
Maintenance service, every 1000 hours .....	303
Maintenance service, every 2000 hours .....	306
Maintenance service, every 4000 hours .....	309
Maintenance service, when required .....	310





Table of contents

---

<b>Specifications .....</b>	<b>338</b>
Recommended lubricants .....	338
Fuel system .....	345
Service capacities and change intervals .....	353
Engine .....	356
Electrical system .....	357
Cab .....	360
Hydraulic system .....	362
Machine weights .....	364
Ground pressure .....	366
Dimensions .....	370
Working ranges .....	374
Recommended bucket sizes .....	376
Digging forces .....	378
Lifting capacities .....	380
Service history .....	394
<b>Alphabetical index .....</b>	<b>397</b>



A series of horizontal dotted lines for writing, consisting of 20 lines spaced evenly down the page.

## Presentation

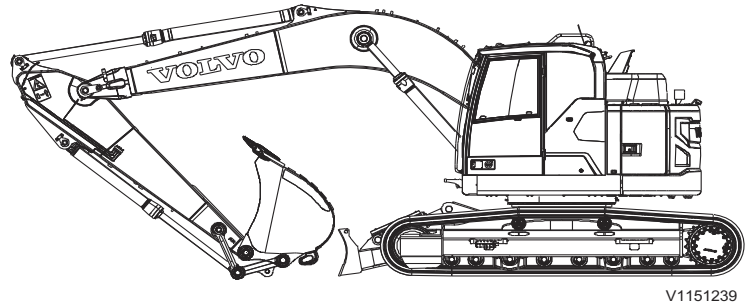

### Intended use

The machine is intended to be used under normal conditions for the applications described in this manual. If it is used for other purposes or in potentially dangerous environments, for example explosive atmosphere, flammable environment or areas with dust containing asbestos and so on, special safety regulations must be followed and the machine be equipped for such use. Contact the manufacturer / dealer for further information.

### Environmental requirements

Be aware of the environment when operating and during service and maintenance of the machine. Always follow local and national environmental legislation applicable to all handling of the machine.

### Engine

The machine is equipped with a straight six-cylinder, four-stroke, turbocharged diesel engine with direct injection and charge-air cooler.

The engines are equipped to meet the legal requirements for exhaust emissions according to US Tier 4 final, California Tier 4 final, or EU Stage V.

#### **NOTE!**

Machines with engines for the US market may not be sold or used within the EU, and machines with engines for the EU market may not be sold or used within the USA, unless the engine is replaced with an engine valid for the applicable market. The market for which the engine is intended is indicated on the emission plate and by the engine's serial number (see page 25).



In order to reduce nitrogen oxides, particles, hydrocarbons and carbon monoxide, the engine includes external, cooled exhaust gas recirculation (EGR) and an exhaust aftertreatment system (EATS) with AdBlue®/DEF injection.

The exhaust aftertreatment system is a certified spark arrestor in accordance with Directive 97/68/EC and EN 1834.

### **AdBlue®/DEF information**

AdBlue®/DEF is needed for the reduction of nitrogen oxides (NO<sub>x</sub>). AdBlue®/DEF is filled in a separate tank on the machine that is completely separate from the fuel tank. AdBlue®/DEF must not be mixed into the diesel tank and diesel must not be mixed into the AdBlue®/DEF.

**For distribution of AdBlue®/DEF (only valid for US market):**

- Volvo CE Customer Support: 1-877-823-1111 (business hours)
- [www.volvoce.com](http://www.volvoce.com) (outside of business hours)

**For distribution of AdBlue®/DEF (all other markets), please contact your local Volvo dealer for more information.**

**See page 311 for information about filling AdBlue®/DEF.**



## Exhaust aftertreatment system

The engine features an exhaust aftertreatment system (EATS) in the form of two mufflers. The first one contains a diesel oxidation catalyst (DOC) and a diesel particulate filter (DPF) to reduce emissions of particulate matter (PM). The second one contains a selective catalytic reduction catalyst (SCR) to reduce nitrogen oxide (NO<sub>x</sub>) emissions. AdBlue®/DEF is injected into the exhausts in order to reduce NO<sub>x</sub>.

The DPF traps particles from the engine exhausts and, since it is continuously loaded with these particles from the exhausts, it needs to be regenerated in order to burn off the particles. Regeneration is also required to release trapped sulphur (SO<sub>2</sub>) and other substances that are trapped in the SCR and reduce the SCR's efficiency if they are not removed.

In order to ensure reduction of NO<sub>x</sub>-emissions, the EATS is monitored by the aftertreatment control module (ACM).

For more information, see page 180.

## Electrical system

The electrical system consists of engine starting system, charging system, machine monitoring system, engine / pump control system and air conditioning system.

The machine is equipped with a high capacity electrical system well protected. Waterproof double-lock harness plugs are used to secure corrosion-free connections. The main relays and solenoid valves are shielded to prevent damage. The master switch is standard.

## Automatic idling system

Automatic idling system reduces engine speed to idle when the levers and pedals are not activated for a certain period of time, resulting in less fuel consumption and low cab noise level.

## Automatic engine shut-down system

### (Optional equipment)

Automatic engine shut-down system is to stop the engine automatically when the machine is not operated for a certain period of time. Default time is set at 5 minutes and can be changed with Volvo's service tool only. Contact a workshop authorized by Volvo.

### Automatic engine shut-down conditions

- Control lockout lever is down.
- Engine speed control switch is not changed.
- DPF regeneration is not on progress.

1 minute before engine shut-down, info screen will be displayed on IC (Instrument Cluster) so that the operator can cancel engine shut-down by pushing the keypad ESC button or moving the control lockout lever up or changing engine speed control switch (at the control lockout lever down position).



## Cab

The operator's cab has easy access via a wide door opening. The cab is supported on hydraulic dampening mounts to reduce shock and vibration level. These along with sound absorbing lining provide low noise levels. The cab has excellent all-round visibility. The front windshield can easily slide up into the ceiling, and the lower front glass can be removed and stored in the right side of the cab.

### **Integrated air-conditioning and heating system**

The pressurized and filtered cab air is supplied by an automatically-controlled fan. The air is distributed throughout the cab from 8 vents.

### **Ergonomic operator's seat**

The adjustable seat and joystick console move independently to accommodate the operator. The seat has 12 different adjustments plus a seat belt for the operator's comfort and safety.



## FOPS and FOG

The cab is designed to meet the requirements for falling objects, the weight of which agrees with testing methods according to FOPS and FOG.

The cab is approved as a part of protective structure according to FOPS and FOG standards. (FOPS: ISO10262 (Level II), FOG: ISO10262:1998 (Level II) and SAE J1356)

FOPS is an abbreviation of Falling Object Protective Structure (top guard) and FOG is an abbreviation of Falling Object Guard (top guard and front guard).

## ROPS

The cab is approved as a part of protective structure according to ROPS standard (ISO12117-2).





## Hydraulic system

The hydraulics system, combined with the fully electronic control system and advanced ECO mode, has been optimized to work in harmony with engine to match the engine power, reduce power loss and improve controllability and response time.

- 1 Summation system: Combines the flow of both hydraulic pumps to ensure quick cycle times and high productivity.
- 2 Boom priority: Gives priority to the boom up function for faster cycle times during loading and deep excavations.
- 3 Arm priority: Gives priority to the arm operating function for faster cycle times during digging and dumping.
- 4 Swing priority: Gives priority to the swing function during trenching application to improve productivity.
- 5 Regeneration system: Prevents cavitation and provides flow to other functions during simultaneous operations for maximum productivity.
- 6 Power boost: All digging and lifting forces are increased.
- 7 Holding valves: Boom and dipper arm holding valves are provided to minimize cylinder drifting while holding loads.



### **Track motor and gearbox**

Each track is powered by an automatic two-speed shift travel motor. The track brakes are multi-disc, spring-applied and hydraulic released. The travel motor, brake and planetary gears are well protected within the track frame.

### **Swing system**

The swing system uses an axial piston motors, driving a planetary gearbox for maximum torque. An automatic holding brake and anti rebound valve are standard



## Equipment

The machine can be equipped with different types of optional equipment, depending on the requirements of different markets. Examples of such equipment are automatic engine shutdown, and automatic lubricating system (standard on certain markets).

## Modifications

Modifications of this machine and its components such as engine and auxiliary system, including the use of unauthorized attachments, accessories, units, or parts, may affect the machine's integrity (condition), the machine's ability to function in the way for which it is designed and voids the EU type-approval of the machine and engine- and auxiliary system. Persons or organizations performing unauthorized modifications assume all responsibility for consequences that arise due to modifications or can be attributed to modifications, including damages to the machine.

No modifications of any kind may be performed on this product unless each specific modification first has been approved in writing by Volvo Construction Equipment. Volvo Construction Equipment reserves the right to reject all warranty claims that have arisen due to or can be traced to unauthorized modifications.

Modifications may be considered to be officially approved, if at least one of the following conditions has been met:

- 1 The attachment, the accessory, the unit, or the part has been manufactured or distributed by Volvo Construction Equipment and has been installed according to the factory-approved method described in a publication available from Volvo Construction Equipment; or
- 2 The modification has been approved in writing by the Engineering Department for the relevant product line at Volvo Construction Equipment.



### Anti-theft device (optional equipment)

An installed anti-theft device makes it more difficult to steal the machine. Volvo Construction Equipment can supply an anti-theft device as optional equipment. If your machine is not equipped with such a device, look into the possibility of having one installed by a qualified service technician.

### Logged machine data

The machine is equipped with a software system, which records various information about the machine and this information is transferred from the machine to Volvo and used by Volvo and its authorized workshops in the product development process and for possible malfunction detection. Questions regarding this information can be directed to your dealer.

### CareTrack

The machine may be equipped with CareTrack, a telematics system developed by Volvo Construction Equipment. The system stores machine data, e.g., machine position, operating hours, fuel consumption, fuel level, that can be sent by wireless transmission to a computer. CareTrack is available in different versions, depending on the required information level.

CareTrack makes it easier to plan for service and reduces costly downtime. Productivity is improved by knowing if machines are being operated correctly and how much fuel is being consumed. CareTrack also allows the customer to restrict the operating area of the machine, by using virtual fences. This helps to eliminate unauthorized machine use and theft. For further information, contact a Volvo Construction Equipment dealer.

The CareTrack system transmits data, in the same way a mobile phone does, with a maximum output rate of 10 W. The transmitter is always on and the operator cannot switch it off.

Local precautions and restrictions applicable to mobile phones, for example safety distance, also apply to the CareTrack system.

## Machine view

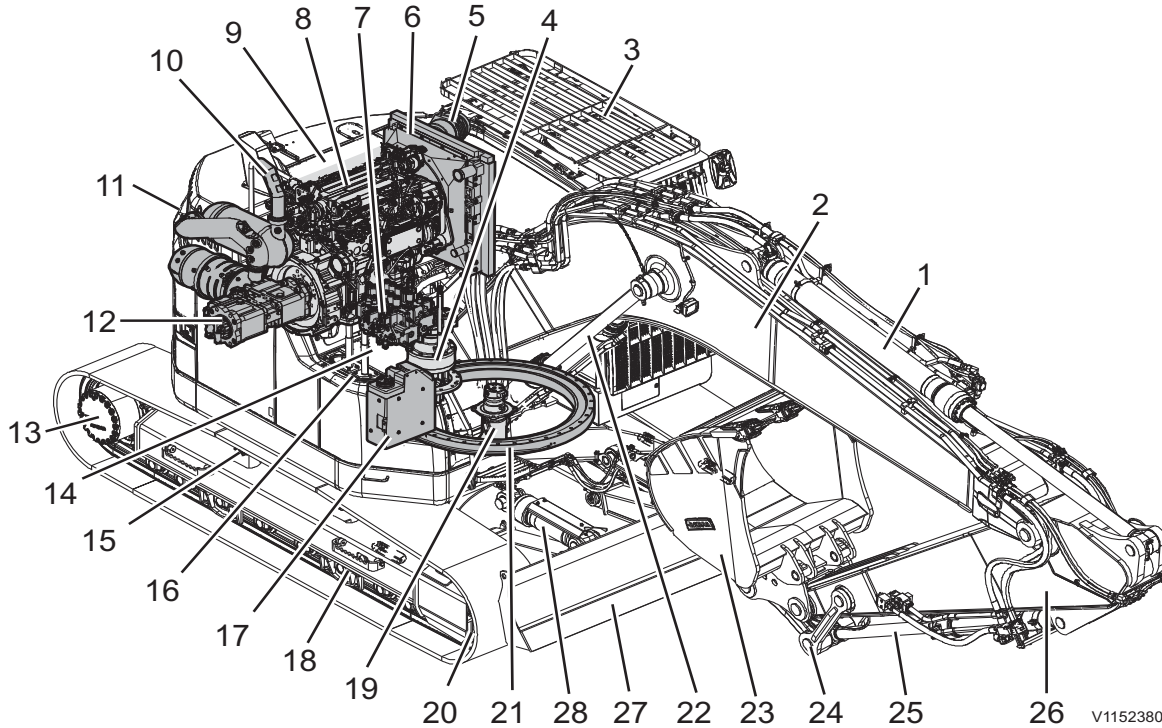

V1152380

1	Dipper arm cylinder	15	Top roller
2	Boom	16	Fuel tank
3	Operator cab	17	AdBlue®/DEF tank
4	Swing motor and gearbox	18	Bottom roller
5	Air cleaner	19	Turning joint
6	Charge air cooler, hydraulic oil cooler, and radiator	20	Idler
7	Main control valve	21	Swing ring gear
8	Engine	22	Boom cylinder
9	Rear hood	23	Bucket
10	Muffler	24	Link
11	Counterweight	25	Bucket cylinder
12	Main pump	26	Dipper arm
13	Track motor and gearbox	27	Dozer blade
14	Hydraulic tank	28	Dozer blade cylinder



V1067840

## CE-marking, EMC-directive

### CE marking

(Declaration of Conformity : Only applies to machines marketed within the EU/EEA.)

This machine is CE marked. This means that when delivered the machine meets the applicable "Essential Health and Safety Requirements", which are given in the EU Machinery Safety Directive, 2006/42/EC.

Any person carrying out changes that affect the safety of the machine, is also responsible for the same.

As proof that the requirements are met, the machine is supplied with an EU Declaration of Conformity, issued by Volvo CE for each separate machine. This EU declaration also covers attachments manufactured by Volvo CE. The documentation is a valuable document, which should be kept safe and retained for at least ten years. The document should always accompany the machine when it is sold.

If the machine is used for other purposes or with other attachments than described in this manual, safety must at all times and in each separate case be maintained. The person carrying out such action is also responsible for the action which, in some cases, may require a new CE marking and the issue of a new EU Declaration of Conformity.



### EU EMC Directive

The electronic equipment of the machine may in some cases cause interference to other electronic equipment, or suffer from external electromagnetic interference, which may constitute safety risks.

The EU EMC directive about "Electromagnetic compatibility", 2014/30/EC, provides a general description of what demands can be made on the machine out of a safety point of view, where permitted limits have been determined and given according to international standards.

A machine or device which meets the requirements should be CE marked. Our machines have been tested particularly for electromagnetic interference. The CE marking of the machine and the declaration of conformity also cover the EMC directive.

If other electronic equipment is fitted to this machine, the equipment must be CE marked and tested on the machine with regard to electromagnetic interference.



22 Presentation  
CE-marking, EMC-directive

**EC DECLARATION OF CONFORMITY FOR MACHINERY (IIA)**

Volvo Construction Equipment hereby declares that the below specified product:

- Manufacturer:** Volvo Construction Equipment AB
- Address:** 160, Doosanvolvo-ro, Seongsan-gu, Changwon-si, Gyeongsangnam-do, 642-430
- Country:** Korea
- Category:** Earth Moving Machinery
- Make:** Volvo
- Type:** Hydraulic Excavator
- Model:** ECXXXX, ECRXXXX, EWXXXX
- Power [kW]:** XXX
- Representative sound pressure [dB(A)]:** XXX
- Guaranteed sound pressure [dB(A)]:** XXX
- PIN:** \*VCEXXXXXXXXXXXXXXXXX\*
- In conjunction with**
- Type:** N/A
- Model:** N/A
- s/n:** N/A

in the state in which it was placed on the market, and excluding components added and/or operations carried out subsequently is in conformity with the relevant provisions of Essential Health and Safety requirements of:

- EC Directive "Machinery":** 2006/42/EC
  - EC Directive "Outdoor Noise":** 2000/14/EC
  - EC Directive "Electromagnetic Compatibility":** 2014/30/EC
- and their amendments relating to machinery, and other applicable directives

The following harmonized standards apply:

- Earth Moving machinery - Safety Part 1:** EN 474-1:2006+A5:2018
- Earth Moving machinery - Safety Part 5:** EN 474-5:2006+A3:2013
- Technical file compiled by:** XXXXXX, D-54329 KONZ, Germany
- Notified Body:** 1067; AV Technology Ltd., AVTECH House, Birdhall Lane, Cheadle Heath, Stockport. SK3 0XU, UK.

This declaration includes attachments developed designed/approved, marked and marketed by above-mentioned manufacturer.

the identity and signature of the person empowered to draw up the declaration on behalf of the manufacturer

the identity and signature of the authorised representative

XXXXXX; XXXXXX

Changwon, Korea	dd/mm	yyyy	Place	date	year
-----------------	-------	------	-------	------	------



## Communication equipment, installation

### **NOTICE**

All installation of optional electronic communication equipment must be performed by trained professionals and in accordance with the Volvo Construction Equipment instructions.

### **Protection against electromagnetic interference**

This machine has been tested in accordance with EU directive 2014/30/EC governing electromagnetic interference. It is therefore very important that all non-approved electronic accessories, such as communication equipment, should be tested before installation and use, since they can cause interference to the electronic systems of the machine.

### **Guidelines**

The following guidelines must be followed during installation:

- The antenna placement must be chosen to give good adaptation to the surroundings.
- The antenna cable must be of the coaxial type. Be careful to ensure that the cable is undamaged, that the sheath and braid are not split at the ends, the braid covers the connector ferrules and has good galvanic contact with them.
- The mating surface between the antenna mounting bracket and the bodywork must have clean metal surfaces, with all dirt and oxide removed. Protect the mating surfaces against corrosion after installation to maintain good galvanic contact.
- Remember to separate interfering and interfered cables physically. Interfering cables consist of the communication equipment's supply cables and antenna cable. Interfered cables are those which are connected to electronic devices in the machine. Install the cables as close as possible to earthed (grounded) sheet metal surfaces, since the sheet metal has a shielding effect.



## Safety components

Genuine Volvo spare parts guarantee the best service life, reliability, and safety for the machine and operator. If reliable and purpose-built parts are not used, your safety, health, and the machine's function may be compromised. Contact your dealer and state the machine's model designation/serial number (PIN-number) when ordering spare parts. Position of PIN-plate, see section "Product plates".

Your Volvo dealer always has up-to-date spare part information that is updated at regular intervals via the information system PROSIS.

### Safety-classified machine and spare parts

Safety-classified machine and spare parts means that the components are intended to fulfil a safety function.

### Examples of safety-classified machine parts/ spare parts

- Removable protective devices/guards over rotating parts and hot surfaces
- Protective plates, rails, covers, and steps
- Components included in systems to reduce sound and vibrations
- Components included in systems to improve the operator's visibility
- Complete operator's seat incl. seat belt
- Decals and plates
- Cab filter

### NOTE!

Safety-classified machine and spare parts shall be reinstalled, repaired, or replaced immediately if they have been removed or damaged.

When changing machine operator/owner, malfunctions and defects of safety-classified machine and spare parts shall be reported immediately and an action plan shall be established.

There is more important information in this Operator's Manual about the components that are considered safety-classified.

## Product plates

Please refer to the figure below to locate the product plate, engine plate, cab plate and attachment plates. Always use the Product Identification Number (PIN) provided on the vehicle and/or engine plates for troubleshooting purposes and/or when ordering spare parts.

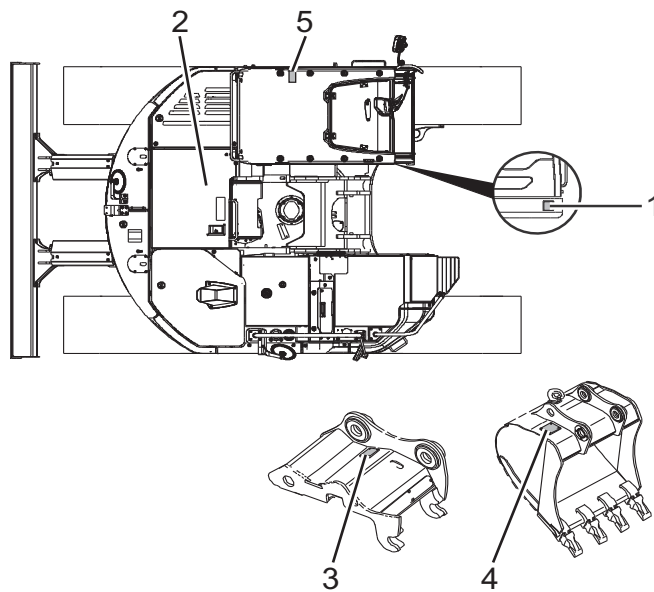

V1151240

### 1 Product plate

This plate with Product Identification Number, PIN, for the complete machine indicates the model designation, serial number and when applicable, machine weight, engine power, manufacturing year and CE approval. The plate is positioned on the right side of the cab.

### 2 Engine

The engine type designation, part and serial numbers are stamped on the top of valve cover.



### 3 Attachment quick coupler

This nameplate is attached on the outside of the quick coupler and indicates the supplier code, serial number, part number and weight.

### 4 Bucket

This nameplate is attached on the top of the bucket and indicates the bucket model order number, serial number, supplier code, rated capacity, weight, cutting width, tooth part number and adapter part number.

### 5 Cab

The nameplate is attached on the inside of the cab and indicates the product number, serial number, model type, and weight.

## Information and warning decals

Information and warning decals are affixed to the machine on strategic locations to remind operators and maintenance personnel specific safety precautions. All decals are not installed on all machines, as they are market and machine dependent. The decals must be kept free from dirt, so that they can be read and understood. If a decal is lost or becomes illegible, it must be replaced immediately. The part number (order number) is given on the respective decals and in the Parts Catalogue.

**NOTE!**

The word **WARNING** is given on the warning decals for North America.

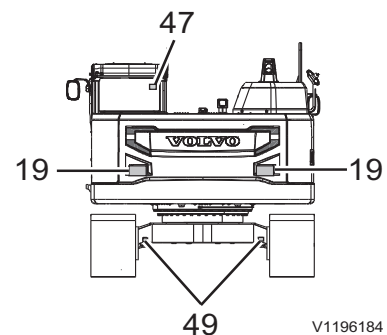
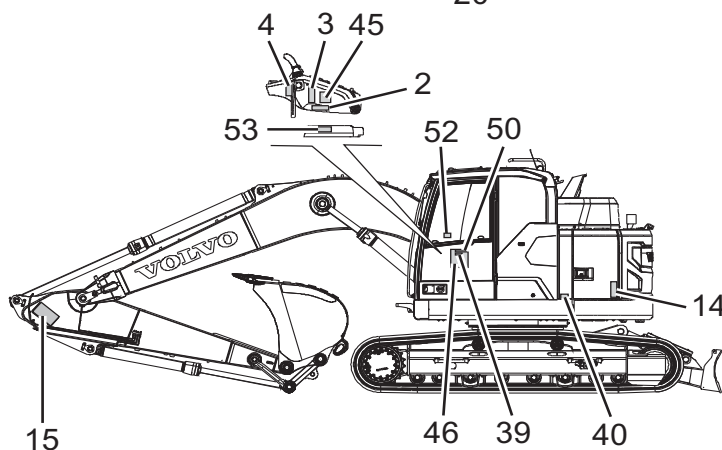
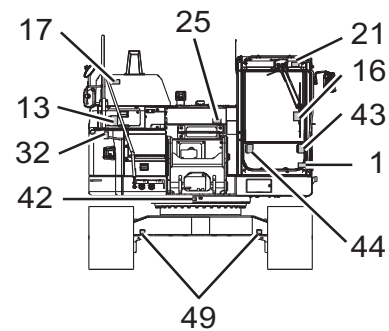
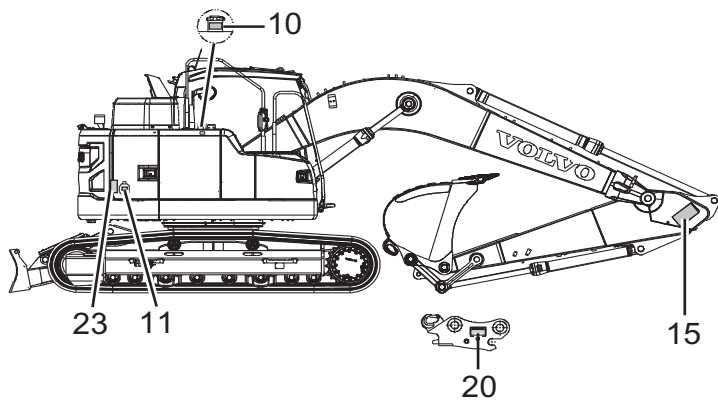
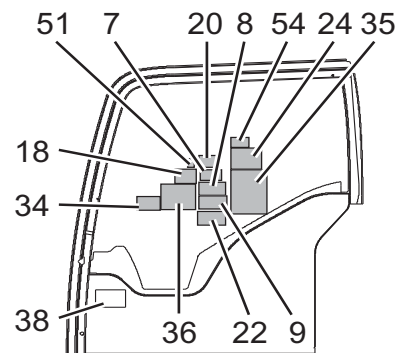
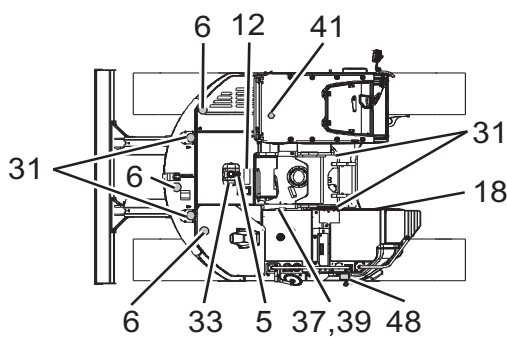

28 Presentation  
Information and warning decals

Warning decals



V1079477

- 1 **WARNING!** Read the Operator's manual.

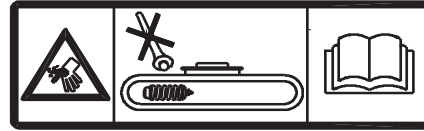

V1065357

- 2 **WARNING!** High pressure, do not unscrew the recoil spring when tensioning tracks – read the Operator's manual. See page 327.

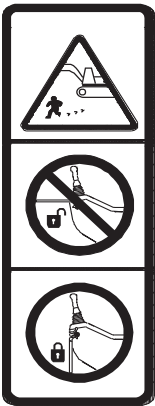

V1065342

- 3 **WARNING!** When leaving the machine, move the control lockout lever down to lock the hydraulic system.



V1079483

- 4 **WARNING!** Do not start the engine.



V1065344

- 5 **WARNING!** Hot and pressurised coolant when opening radiator cap.



V1065343

- 6 **WARNING!** Do not step on this surface.

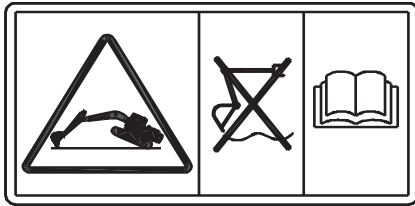

V1092982

- 7 **WARNING!** Do not use floating function while the machine is jacked up – read the Operator's manual. Boom floating (option). See page 219.

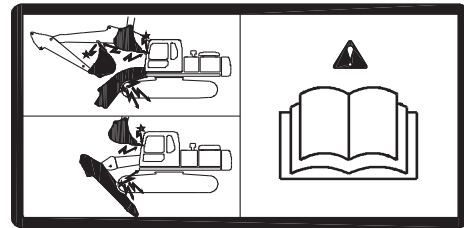

V1093037

- 8 **WARNING!** Operating the optional attachment. Equipment may strike the cab or machine.

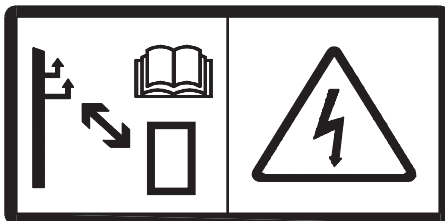

V1079478

- 9 **WARNING!** High voltage, keep safe distance from electrical power lines. Read the Operator's manual. See page 208.



V1079484

- 10 **WARNING!** No smoking when fuel filling.



V1079480

- 11 **WARNING!** Risk of explosion – read the Operator's manual. See page 333.

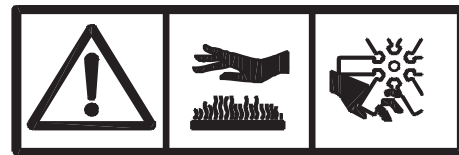

V1079479

- 12 **WARNING!** Hot surfaces and rotating parts

30 Presentation  
Information and warning decals



V1093038

13 WARNING! Risk of falling from machine.



V1077433

14 WARNING! Risk of electrical shock, corrosive burns and explosion – read the Operator's manual.



V1093039

15 WARNING! Raised attachment, keep a safe distance from the machine.



V1065355

16 WARNING! Lock the windshield. WARNING! Insert safety lock before getting into hazardous area.

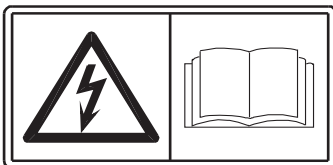

V1134752

17 WARNING! Electric shock.

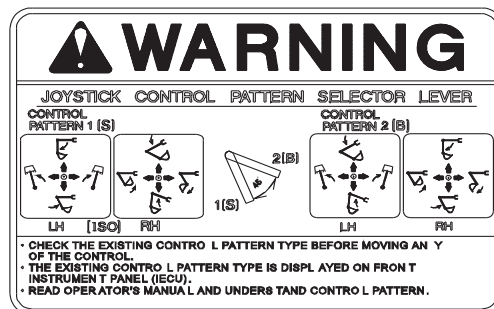

V1065345

18 WARNING! Pattern change valve selector (option). See page 96.



Presentation  
Information and warning decals

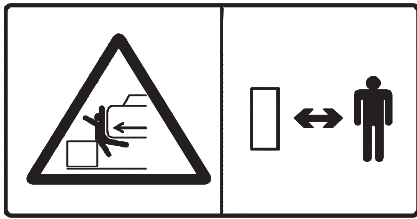

V1065358

19 WARNING! Crushing area, keep a safe distance from the machine.

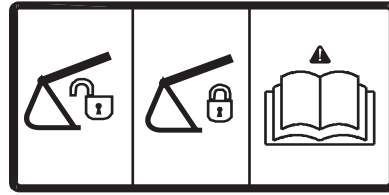

V1093043

20 WARNING! Before working after connecting and disconnecting attachment – read the Operator's manual. (Attachment quick coupler, option)

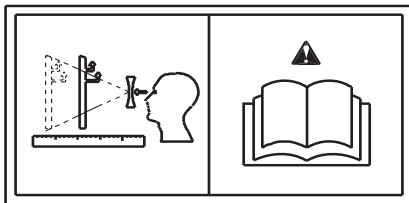

V1093040

21 WARNING! Risk of visual distortion through roof window – read the Operator's manual.

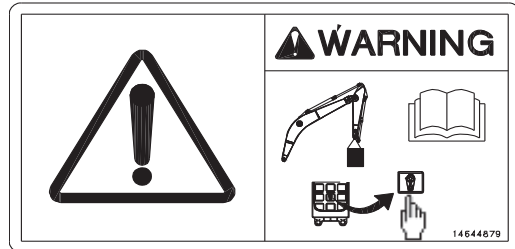

V1123383

22 WARNING! Overload warning button. See page 80.

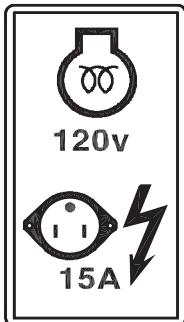

V1093045

23 WARNING! Engine preheater (option).

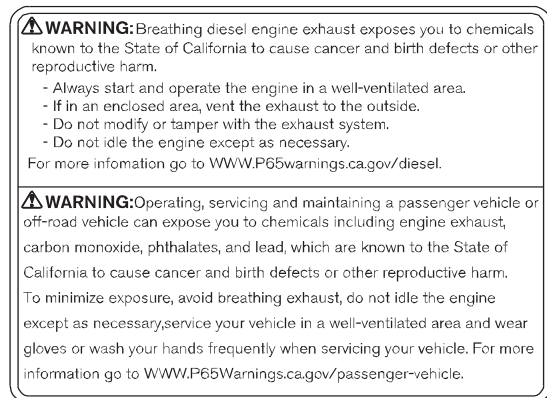

V1196169

24 WARNING! California Proposition 65 requirements (for North America).



V1080419

25 WARNING! Hot surfaces.

## 32 Presentation Information and warning decals

### Information decals



V1065364

31 Lifting point.



V1137928

32 AdBlue®/DEF, filling. See page 311.



V1065366

33 Coolant information – read the Operator's manual. See page 307.

Mode	Applications	
<b>H</b>	Heavy duty	Maximum productivity, High Speed.
<b>G</b>	General	Most general application, Optimum speed.
<b>F</b>	Fine control	Maximum lifting force, Precise control speed.
<b>I</b>	Idle	Warm-up, Low idle speed.

V1065367

34 Mode application (option).

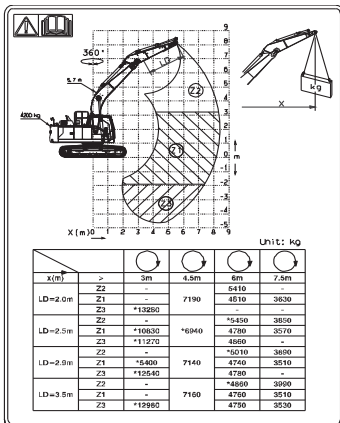

V1148558

35 Lifting capacity (option). See page 380.

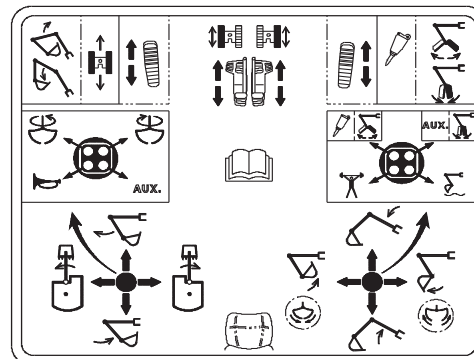

V1099522

36 Lever and pedal functions (option).

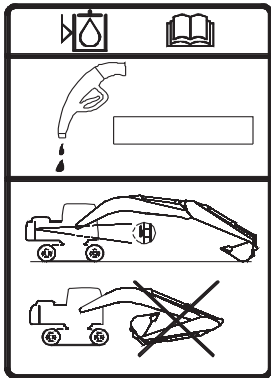

V1065370

37 Machine position when checking hydraulic oil level.

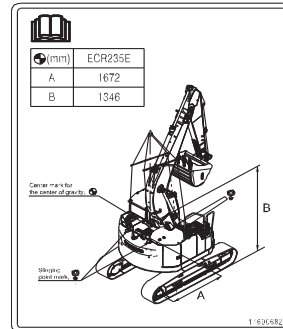

V1151243

38 Lifting instruction. See page 200.



V1093046

39 Type of hydraulic oil filled at factory (option).

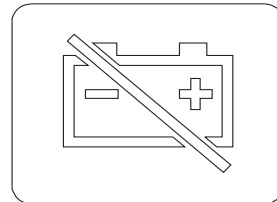

V1125755

40 Battery disconnect switch.



V1093052

41 Sound pressure level in cab (option).

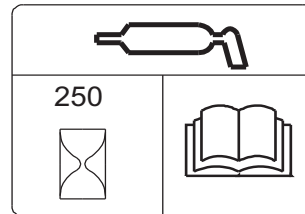

V1065375

42 Greasing interval – read the Operator's manual.

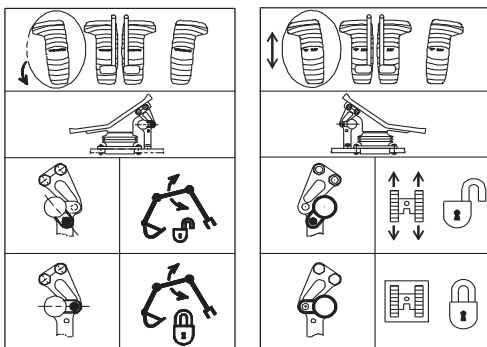

V1068020

43 Optional pedal operation (option).

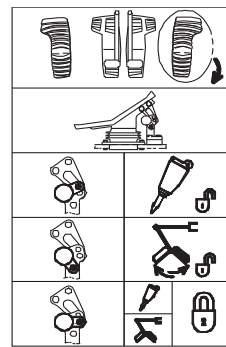

V1065377

44 Optional pedal operation (option).

34 Presentation  
Information and warning decals



V1068021

45 Sound power level outside machine.

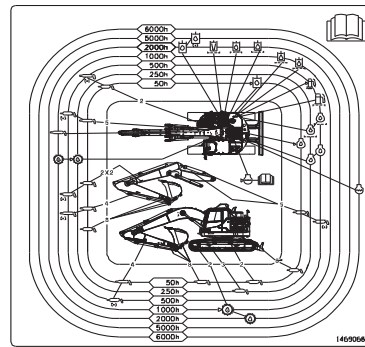

V1151242

46 Lubrication and service chart. See page 281.

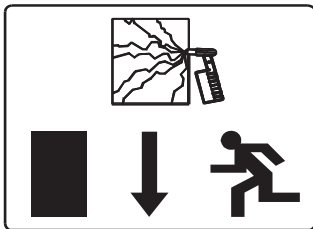

V1129244

47 Emergency exit.



V1099517

48 Sulphur content information (A: for North America, B: for Europe and Other markets). See page 345.



V1065381

49 Tie-down point.



V1065382

50 Long life hydraulic oil. See page 338.

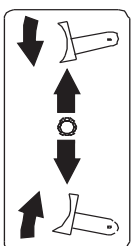

V1099577

51 Dozer blade.

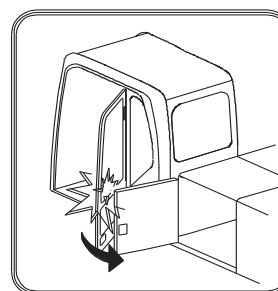

V1065356

52 Be careful when opening the cab door. Risk of cab door window damage.

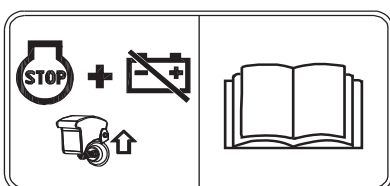

V1137926

53 Emergency stop switch. See page 96.



V1178089

54 Refrigerant information. See page 275 and 361.

# Instrument panels

## WARNING

Risk of serious injury.

Operating the machine without sufficient skills and knowledge of the content in the Operator's Manual could lead to loss of machine control and could cause serious injuries including death.

**Carefully read through the Operator's Manual and learn the warning signs, symbols and operating instructions before attempting to operate the machine.**

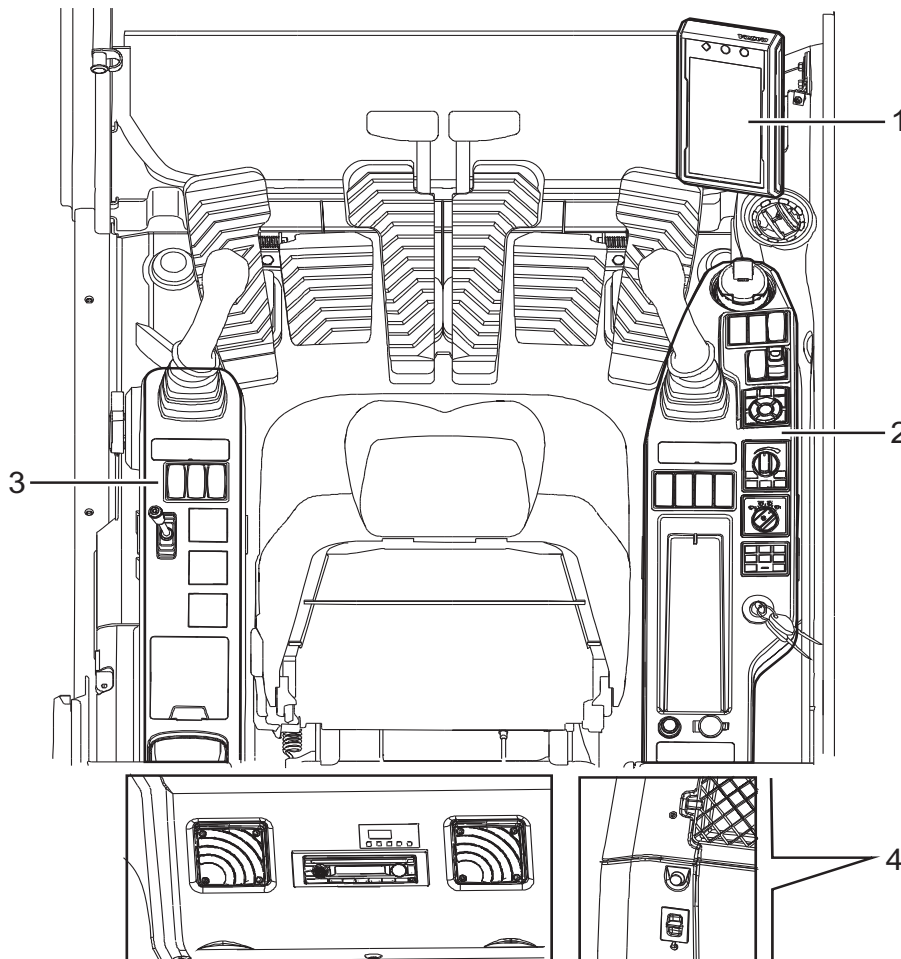

V1151246

1	Front instrument panel (Instrument Cluster)
2	Right instrument panel
3	Left instrument panel
4	Rear instrument panel

## Instrument panel, left

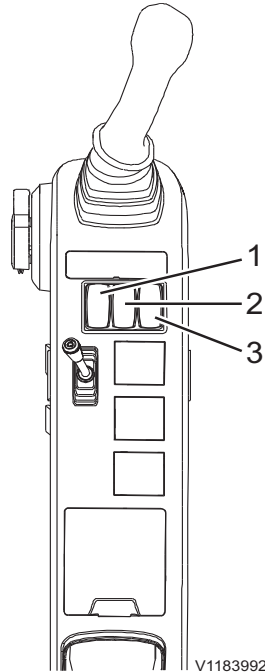

V1183992

- 1 Interior light switch
- 2 Rotating beacon switch (optional equipment)
- 3 Attachment quick coupler switch, left (optional equipment)

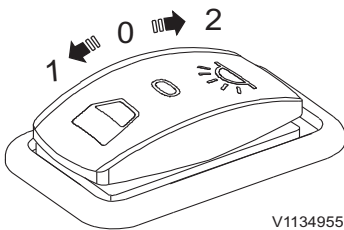

V1134955

### 1 Interior light switch

- Position 0: Interior light is OFF
- Position 1: Interior light (B) will be turned on when the cab door is open. After closing the cab door, the interior light will be turned off automatically.
- Position 2: Interior light is ON

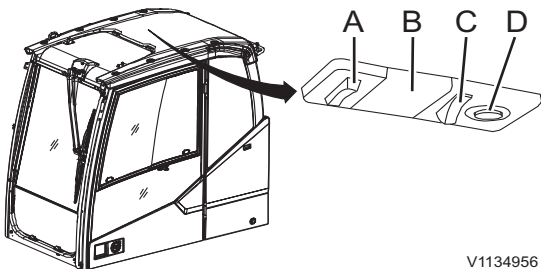

V1134956

The switch (A) for the interior light will only work when this switch is in the "ON" position (2). The reading light (D) can be turned on with switch (C) regardless of the position of the interior light switch.

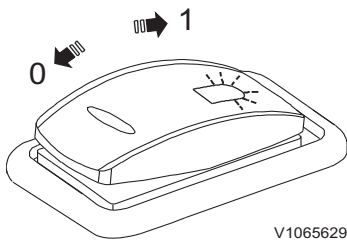

V1065629

## 2 Rotating beacon switch (optional equipment)

- Position 0: Rotating beacon is OFF
- Position 1: Rotating beacon is ON

This switch is used to activate the rotating beacon when the swing system is activated.

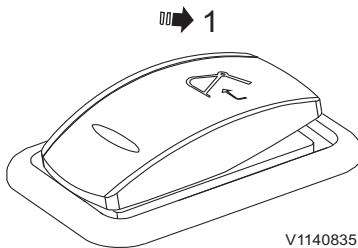

V1140835

## 3 Attachment quick coupler switch, left (optional equipment)

This switch has 2 different functions of the attachment quick coupler according to the operating condition.

- Press down 1: Attachment quick coupler, opening control

The switch is returned automatically. Press the switch for more than 0.7 seconds to open the attachment quick coupler.

When the attachment quick coupler is open, the buzzer sounds and the warning message and indicator are displayed on the IC (Instrument Cluster).

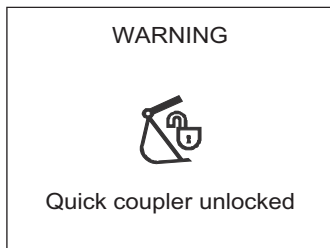

V1147254

Warning! Quick coupler unlocked

### NOTE!

The attachment quick coupler switch for initiating on the right instrument panel must be pressed first to activate this switch. See page 80 for the operation.

- Press down 1: Attachment quick coupler, confirming control

When the check message for confirming appears on the IC (Instrument Cluster), press the switch for more than 0.7 seconds to confirm that the attachment quick coupler is locked. Then the buzzer sound will be turned off and the check message and indicator will disappear.

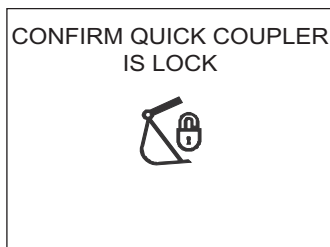

V1147255

Confirm quick coupler is locked

38 Instrument panels  
Instrument panel, front

## Instrument panel, front

The front instrument panel can be adjusted for better operator comfort.

**NOTE!**

Prevent machine damage by taking correct action. Read thoroughly and understand the instructions in this section to familiarize yourself with the front instrument panel before trying to operate the machine.

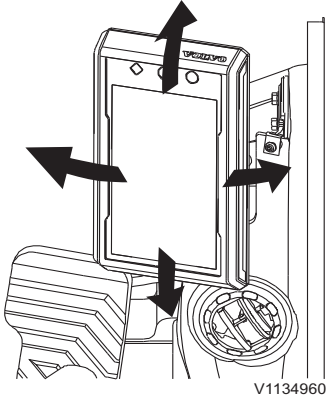

Adjustable direction of IC (Instrument Cluster)

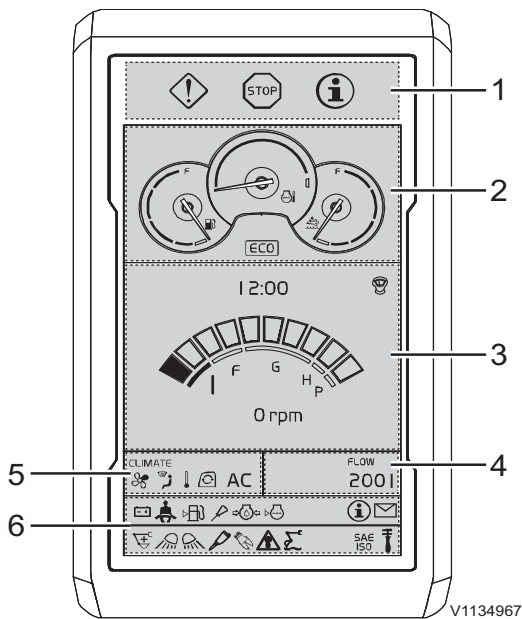

**NOTE!**

The front instrument panel is designed to display one of the supported languages. Refer to page 44 for details on how to set the language and the units.

- 1 Central warning light screen
- 2 Gauge screen
- 3 Time and engine speed screen
- 4 Hydraulic flow screen
- 5 CCM (Climate Control Module) screen
- 6 Indicator screen





A



B



C

V1134961

- A Check, amber
- B Warning, red
- C Information, blue

## 1 Central warning light

There are three different types of light.

For more information, see page 44.

### NOTE!

If the central warning light flashes or lights up while operating, follow the instructions on the display unit.

## 2 Gauges

The gauges are always shown unless a warning message is activated.

### Fuel level gauge

The gauge shows the level in the fuel tank and it has a red mark indicating "fuel empty". When the gauge is in this area, the fuel left is about 10% of total tank capacity. Refuel the machine immediately in order to avoid air entering the system. If the machine runs out of fuel during operation, refuel and refer to page 315 for correct instructions to bleed air from the fuel system.

Fuel tank capacity, see page 353.

### Engine coolant temperature gauge

The gauge shows the temperature of the engine coolant and it has a red mark meaning "engine overheated".

### NOTE!

The red central warning light flashes, if the coolant temperature becomes abnormally high. Turn off the engine immediately and check the cause.

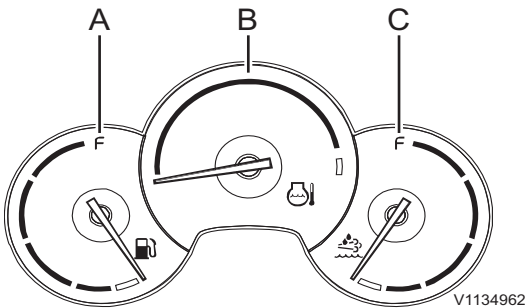

- A Fuel level gauge
- B Engine coolant temperature gauge
- C AdBlue®/DEF level gauge

## 40 Instrument panels Instrument panel, front

### AdBlue®/DEF level gauge

The gauge shows the level in the AdBlue®/DEF tank and it has a red mark indicating "AdBlue®/DEF empty". When the gauge is in this area, the AdBlue®/DEF left is about 10% of total tank capacity.

Capacity of AdBlue®/DEF tank, see page 353.

### 3 Time and engine speed

Time segment displays the current time. Refer to page 44 for instructions on how to set current time on the main screen.

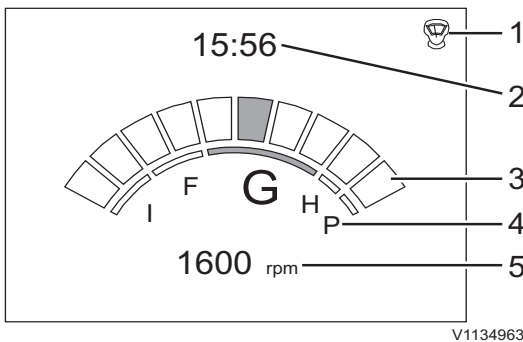

- 1 Joystick shortcut
- 2 Time
- 3 Engine speed step
- 4 Work mode index
- 5 Actual engine speed

Engine speed screen is displayed when the "Menu screen" is not shown in the "Main screen". For main menu screen, see page 44.

The "Engine speed step" selected on "Engine speed control switch" is displayed on an engine speed graph which is a segmented bar graph.

The actual speed is displayed below the engine speed graph (maximum four-digit number).

When the engine is off, engine speed is displayed as "0".

#### NOTE!

Engine speed and work mode may vary according to the optional equipment.

### 4 Hydraulic flow

Calculated value for X1 flow option is displayed on the segment called "Flow segment". Refer to page 44 for flow setting instructions.

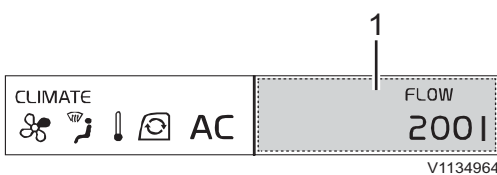

- 1 Flow rate for X1



- 1 Fan speed  
2 Air flow direction  
3 Temperature  
4 Air flow circulation  
5 Air conditioning status

V1134965

## 5 CCM (Climate Control Module)

CCM segment displays the status of the CCM (Climate Control Module). This includes temperature setting, fan speed, air flow direction, circulation, and air conditioning status. Refer to page 117 for more details.

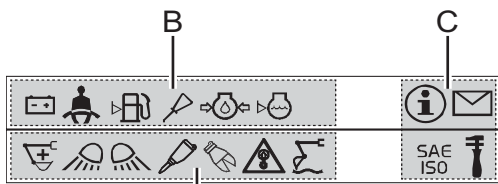

- A Function indicators  
B Warning indicators  
C Fixed indicators

V1134966

## 6 Indicators

Indicator screen displays indicators as symbols that show users important information easily and quickly. Indicators are divided into three types; function indicator, warning indicator, and fixed indicator.

### NOTE!

Fixed indicators are always displayed on the right side.

- Indicators fill the space from left to right.
- An indicator that has higher priority is put on the left side of the one that has lower priority.
- Indicators on both sides can extend their display area to the other side if there is no indicator on the other side.
- When the whole area is filled and there are more indicators to display, indicators keep replacing the others so that the user can see all indicators.

42 Instrument panels  
Instrument panel, front

Indicators and their priorities are as follows;

Table. Function indicators

 V1065463	 V1065465
1. Air preheating	2. Hammer selected (optional equipment)
 V1065466	 V1065467
3. Shear selected (optional equipment)	4. Overload indicator (optional equipment)
 V1065468	 V1129236
5. Boom float position (optional equipment)	6. Power boost selected
 V1065469	 V1065470
7. Rototilt selected (optional equipment)	8. Reversible fan (optional equipment)

Table. Warning indicators

 V1065475	 V1065476
1. Low engine oil pressure	2. Low coolant level
 V1065467	 V1065478
3. Overload warning (optional equipment) Stop the lifting operation and reduce the load.	4. Low engine oil level
 V1065479	 V1065480
5. Open attachment quick coupler (optional equipment) Stop work immediately if the bucket is still attached to the attachment bracket.	6. Wrong battery charge



Instrument panels  
Instrument panel, front













 V1065481	 V1065483
7. High engine coolant temperature	8. Pattern changer warning
 V1065484	 V1065488
9. Clogged engine air filter	10. Seat belt
 V1065486	 V1065487
11. Low fuel level	12. High hydraulic oil temperature
 V1203413	 V1203414
13. AdBlue®/DEF warning	14. Regeneration needed
 V1203415	 V1203416
15. Regeneration, malfunction	16. High exhaust temperature during regeneration

Table. Fixed indicators

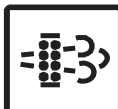
 V1065471	 V1065472
1. Service mode selected (fixed position)	2. Message indicator (fixed position)
 V1065473	 V1065474
3. Pattern changer status (fixed position)	4. Pattern changer status (fixed position)

## Display unit

### Start sequence

Initial start sequence is performed as follows.

#### A Volvo logo

If the operator turns the ignition switch to the operating position, the Volvo logo on the IC (Instrument Cluster) screen lights up for a few seconds.

#### NOTE!

Enter the code for the anti-theft system (if installed), see page 70. If the engine is restarted within 15 seconds (time is adjustable with Volvo's service tool, Tech Tool) after having turned it off, the code does not have to be entered again.



V1137865

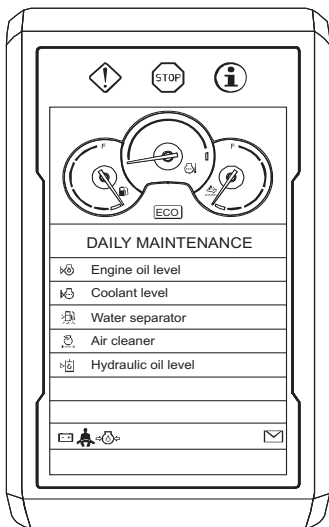

V1137866

#### B Daily maintenance

The user can see daily maintenance items once a day. This screen is dismissed by pressing the ESC button or SELECT button and disappears automatically after 5 seconds if there is no button input.

- Engine oil level
- Coolant level
- Water separator
- Air cleaner
- Hydraulic oil level

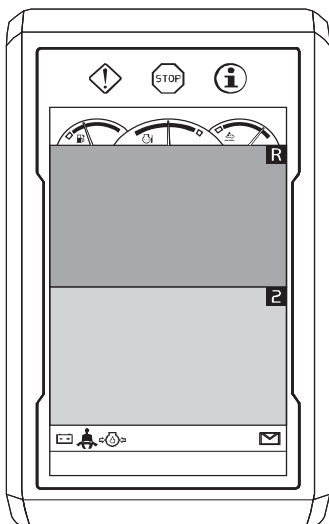

V1170136

#### C Camera screen (if installed)

All the cameras installed on the machine will be displayed on the IC (Instrument Cluster) when engine is running. The camera screen is dismissed by pressing the ESC button on the keypad.

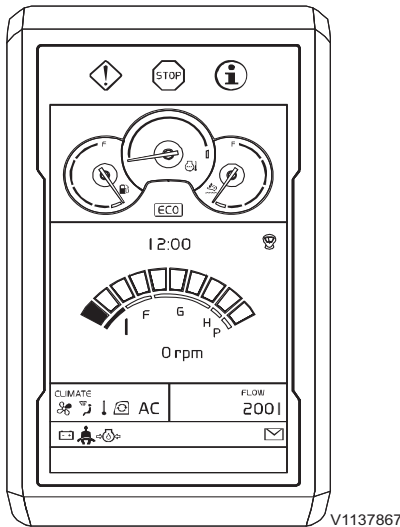

### D Main screen

After the camera screen is dismissed, the main screen is displayed.

#### NOTE!

Indicator for seat belt will be displayed for 3 seconds on the "Daily maintenance" screen or main screen. Fasten the seat belt before operating the machine.

#### NOTE!

Camera screen can be shown again

- when camera button is pressed or
- when operating control lever (joystick) / pedal or
- no keypad signal during 10 seconds.

This function is always to check for obstacles or person near the machine. For detailed information about camera control, see page 130.

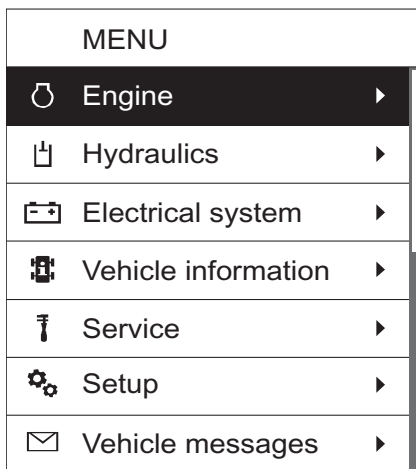

### Main menu

The main menu is reached by pressing the SELECT button on the keypad.

Scroll the list by using the arrow buttons on the keypad. When a folder is highlighted, its subscreens are shown when pressing the SELECT button. Use the arrow buttons to scroll between the subscreens. Cancel the action at any time by pressing the ESC button on the keypad.

## 46 Instrument panels Display unit

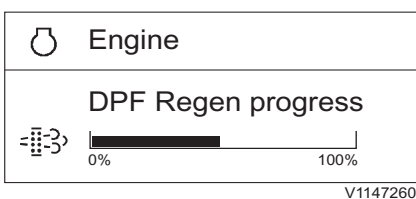
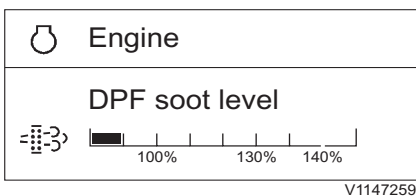
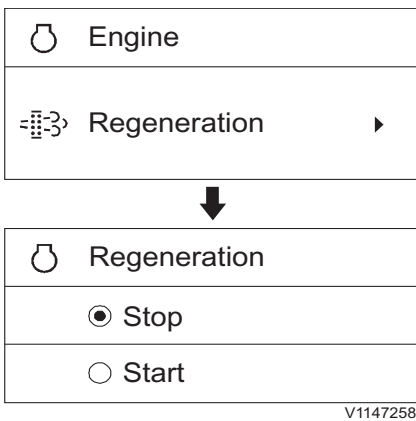
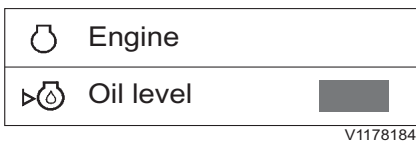
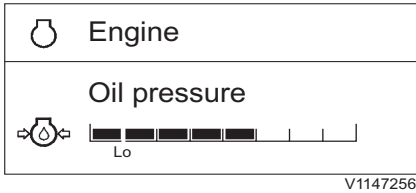

### Subscreens

#### 1 Engine

■ **Oil pressure:** This shows the measured value of the engine oil pressure. When the bar graph is green, the value is OK, within normal operation range. When the bar graph is red, the value is abnormal.

■ **Oil level:** This indicator shows the measured value of the engine oil level. The color of the indicator shows the following:

- **Green:** The value is between 30%-100%, the oil level is OK.
- **Yellow:** The value is between 3%-30%, check the oil level with the dipstick at next daily maintenance.
- **Red:** The value is between 0%-3%, the oil level is too low. Check the oil level immediately with the dipstick and take the necessary actions.
- **Grey:** The value is over 100% or system failure. Contact a workshop authorized by Volvo.

■ **Regeneration:** The operator can perform a regeneration with "Start" in the menu when the Diesel Particulate Filter has collected enough soot. When selecting "Stop" in the menu, the regeneration which is in progress will be cancelled. Refer to page 180 for more detailed information.

- Stop
- Start

■ **DPF soot level:** This shows the level of soot that has accumulated within the DPF.

**NOTE!**

Contact a workshop authorized by Volvo for detailed information on the soot level.

■ **DPF Regen progress:** This shows the measured value of DPF regeneration progress. Regeneration is complete when the bar graph reaches 100%.



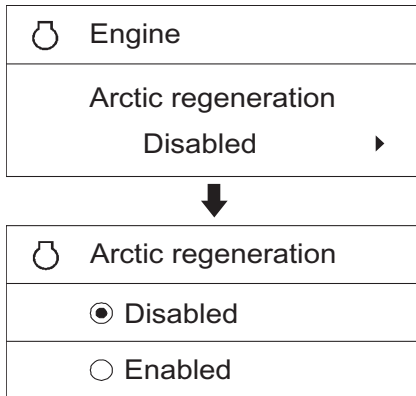

V1147262

- **Arctic regeneration (optional equipment):** Arctic regeneration mode is used for machines that operate in extreme cold climate areas where the machines need to be left running around-the-clock without operator presence. To use this optional mode, the parked regeneration mode should be selected in advance. When selecting "Enabled" in this menu, the parked regeneration is started automatically when needed without any further operator action. This function will only be active while in parked mode, regardless of regeneration mode and will be "Disabled" by default at startup or when leaving the parked mode. This means that the regeneration system can remain in an optimal mode, even after longer periods of idling.

  - Disabled
  - Enabled

## 48 Instrument panels Display unit

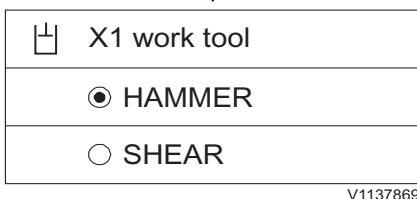
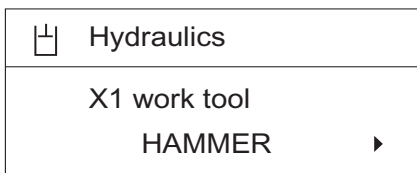
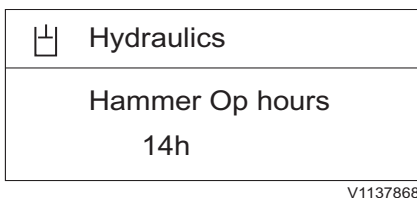
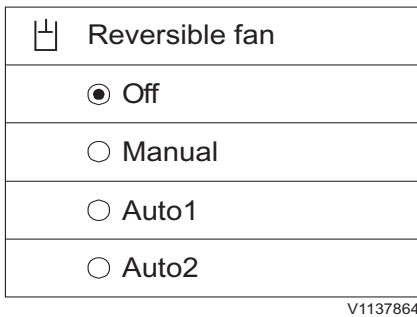
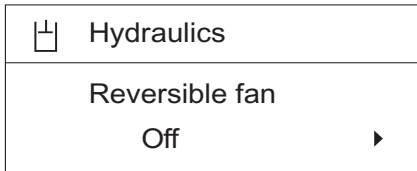
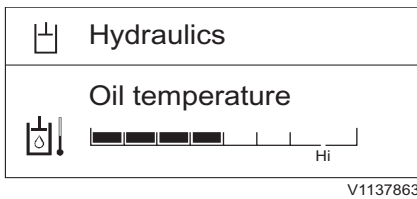

### 2 Hydraulics

■ **Oil temperature:** This shows the measured value of hydraulic oil temperature. When the bar graph is green, the value is OK, within normal operation range. When the bar graph is red, the value is abnormal.

■ **Reversible fan (optional equipment):** This informs the operator which mode is selected at the moment. It also allows the operator to select a reversible fan mode from 4 different modes. The operator can select a reversible fan mode with the arrow buttons. When pressing the SELECT button, the marked mode is set. The screen reverts to the former screen displaying the newly selected mode.

- **Off mode:** Normal rotation or stopping reverse rotation.
- **Manual mode:** Reverses the rotation one cycle immediately after setting the mode.
- **Auto1 mode / Auto2 mode:** Repeats a cycle consisting of normal rotation and reverse rotation.

For more information, see page 218.

■ **Hammer op. hours (optional equipment):** This shows the counted value of hammer operating time in the unit hours and it can not be reset to zero.

#### NOTE!

Refer to this "Hammer op. hours" for service interval when replacing the hammer return filter.

■ **X1 work tool (optional equipment):** This informs the operator which tool is selected at the moment. It also allows the operator to select a preset tool showing the name and settings of each tool. When pressing the arrow button, another preset work tool is displayed. When pressing the SELECT button for another tool, the screen reverts the screen to the former screen displaying the name of the newly selected tool.

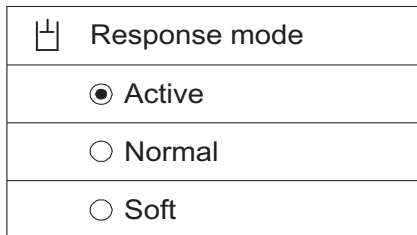
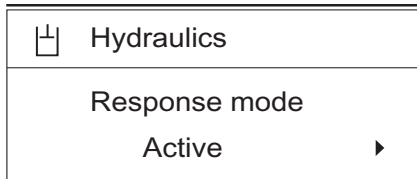

V1137871

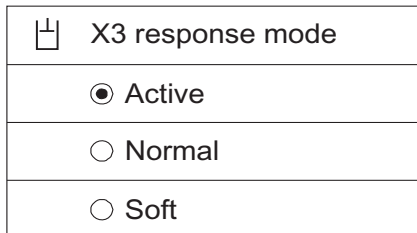
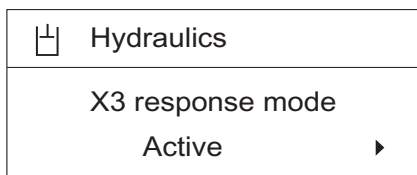

V1137870

■ **Response mode (optional equipment):** This informs the operator which response mode is selected at the moment. It also allows to select a response mode from 3 different modes. The operator can select a response mode from the three modes with the arrow buttons. When pressing the SELECT button, the marked response mode is set. The screen reverts to the former screen displaying the name of the newly selected item.

- Active
- Normal
- Soft

The operator can adjust the movement sensitivity of attachments when operating the levers. "Active" mode is the most sensitive.

■ **X3 response mode (optional equipment):** This informs the operator which X3 response mode is selected at the moment. It also allows to select a response mode from 3 different modes. The operator can select a X3 response mode from the three modes with the arrow buttons. When pressing the SELECT button, the marked response mode is set. The screen reverts to the former screen displaying the name of the newly selected item.

- Active
- Normal
- Soft

The operator can adjust the movement sensitivity of attachments when operating the levers. "Active" mode is the most sensitive.

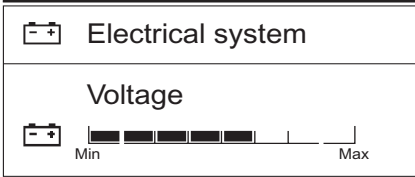

	Vehicle information
Model	XXXXXX
Serial number	XXXXXX
Operating hour	XXXX.X h

V1168450

	Vehicle information
Work timer	37h 43min ▶



	Work timer
37h 43min	Reset work timer ▶



	Reset work timer?
Yes	

V1140744

### 3 Electrical system

- **Voltage:** This shows the measured value of voltage of the battery. When the bar graph is green, the value is OK, within normal operation range. When the bar graph is red, the value is abnormal.

### 4 Vehicle information

- **Model:** This shows the machine's model name.
- **Serial number:** This shows the machine's serial number.
- **Operating hour:** This shows the machine's operating hours.

- **Work timer:** This shows the counted work time.
  - **Reset work timer:** Work time can be reset by pressing the SELECT button when the "Work timer" value is highlighted. Press ESC button to "Cancel" or SELECT button to "Yes".

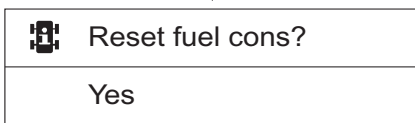
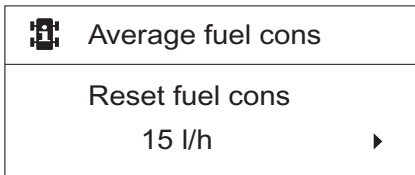
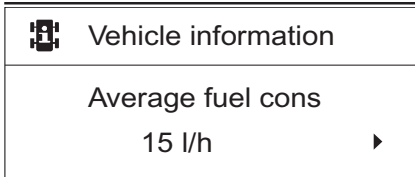

V1140745

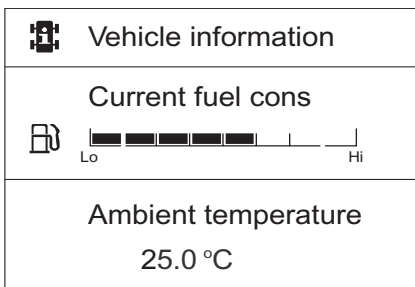

V1137877

■ **Average fuel cons.:** This shows the calculated average fuel consumption from the last 24 hours.

- Reset fuel cons: Fuel consumption can be reset by pressing the SELECT button when the "Average fuel cons" value is highlighted. Press the ESC button to "Cancel" or SELECT button to "Yes".

■ **Current fuel cons.:** This shows the calculated fuel consumption at the current time.

■ **Ambient temp:** This shows the measured ambient temperature.

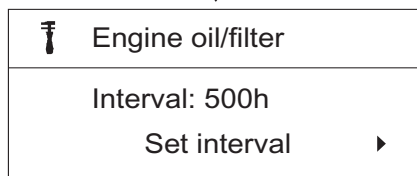
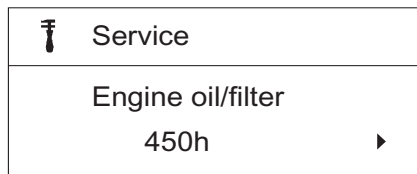

V1137878

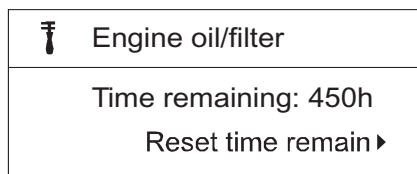

V1137879

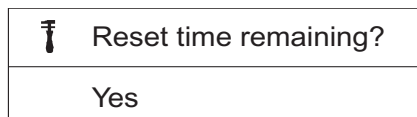

V1140746

## 5 Service

This subscreen shows the service items with "time remaining" value. Press the SELECT button to adjust interval or to check detail information.

### ■ Engine oil/filter

- Interval: This shows the value of engine oil/filter interval in the unit hours. According to engine oil/filter type, the operator can adjust engine oil/filter interval. The setting range is 50 ~ 500 hours.

- Time remaining: This shows the value for remaining time to next engine oil/filter service. When the "Time remaining" reaches 40 h, 20 h, and 0 h, the check screen with "Time remaining" and "Interval" will pop up on the IC (Instrument Cluster). Service the maintenance items which should be serviced in that interval. For the service interval and maintenance items, see page 354.

- Reset time remaining?: After servicing the maintenance items, the time can be reset. Press ESC button to "Cancel" or SELECT button to "Yes". When the time is reset, the next service interval and "Time remaining" will be displayed.

If the operator does not replace the engine oil/filter and resets this value, it turns to zero and then to negative.

 Service
Fuel filter/Water sep 450h ▶



 Fuel filter/Water sep
Interval: 500h Set interval ▶



 Fuel filter/Water sep
Set interval: ◆ 500h

V1137881

 Fuel filter/Water sep
Time remaining: 450h Reset time remain ▶

V1137882

 Reset time remaining?
Yes

V1140746

■ Fuel filter/Water sep

- Interval: This shows the value of fuel filter/ water separator interval with in the unit hours. The operator can adjust fuel filter/water separator interval. The setting range is 50 ~ 500 hours.

- Time remaining: This shows the value for remaining time for next fuel filter/water separator service. When the "Time remaining" reaches 40 h, 20 h, and 0 h, the check screen with "Time remaining" and "Interval" will pop up on the IC (Instrument Cluster). Service the maintenance items which should be serviced in that interval. For the service interval and maintenance items, see page 354.
- Reset time remaining?: After servicing the maintenance items, the time can be reset. Press ESC button to "Cancel " or SELECT button to "Yes". When the time is reset, the next service interval and "Time remaining" will be displayed. If operator does not maintain the parts and reset this value it turns to zero and then to negative.

## 54 Instrument panels Display unit

 Service
Hydraulic oil 1500h ▶



 Hydraulic oil
Interval: 2000h Set interval ▶



 Hydraulic oil
Set interval: ◆ 2000h

V1137883

 Hydraulic oil
Time remaining: 1500h Reset time remain ▶

V1137884

 Reset time remaining?
Yes

V1140746

 Hydraulic oil
Hammer Op hours: 20h

V1137885

### ■ Hydraulic oil

- Interval: This shows the value of hydraulic oil interval in the unit hours. The operator can adjust the hydraulic oil interval. The setting range is 100 ~ 5000 hours.

- Time remaining: This shows the value for remaining time to next hydraulic oil service. When the "Time remaining" reaches 40 h, 20 h, and 0 h, the check screen with "Time remaining" and "Interval" will pop up on the IC (Instrument Cluster). Service the maintenance items which should be serviced in that interval. For the service interval and maintenance items, see page 354.

- Reset time remaining?: After servicing the maintenance items, the time can be reset. Press ESC button to "Cancel " or SELECT button to "Yes". When the time is reset, the next service interval and "Time remaining" will be displayed.

If operator does not maintain the parts and reset this value it turns to zero and then to negative.

- Hammer op. hours: This shows the counted value of hammer operating time in the unit hours. "Hammer op. hours" is not adjustable. It is automatically reset to zero when "Time remaining" is reset and shows the hammer operating hours from the reset point.



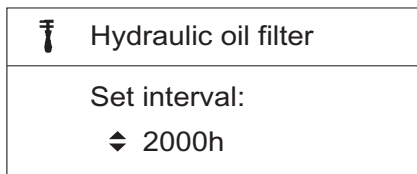
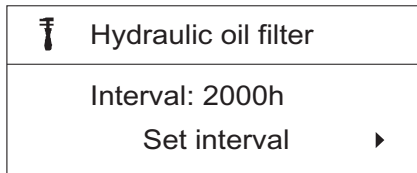
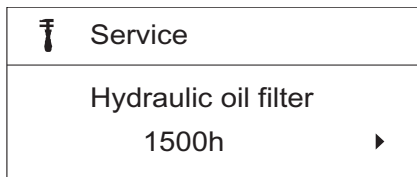

V1137886

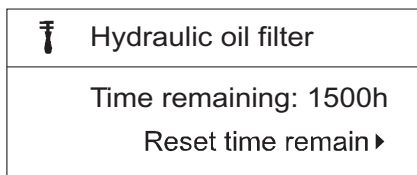

V1137887

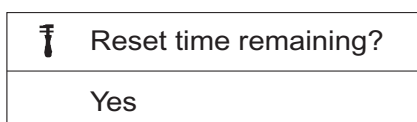

V1140746

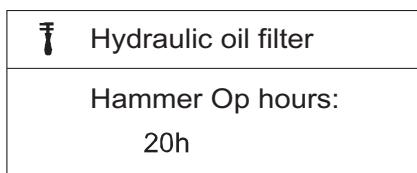

V1137888

#### ■ Hydraulic oil filter

- Interval: This shows the value of hydraulic oil filter interval in the unit hours. The operator can adjust the hydraulic oil filter interval. The setting range is 100 ~ 2000 hours.

- Time remaining: This shows the value for remaining time to next hydraulic oil filter service. When the "Time remaining" reaches 40 h, 20 h, and 0 h, the check screen with "Time remaining" and "Interval" will pop up on the IC (Instrument Cluster). Service the maintenance items which should be serviced in that interval. For the service interval and maintenance items, see page 354.
- Reset time remaining?: After servicing the maintenance items, the time can be reset. Press ESC button to "Cancel " or SELECT button to "Yes". When the time is reset, the next service interval and "Time remaining" will be displayed. If operator does not maintain the part and reset this value it turns to zero and then to negative.
- Hammer op. hours: This shows the counted value of hammer operating time in the unit hours. "Hammer op. hours" is not adjustable. It is automatically reset to zero when "Time remaining" is reset and shows the hammer operating hours from the reset point.

 Setup
X1 work tool ▶



 X1 work tool
Enter password: * * * *



 X1 work tool
New ▶
Change ▶
Delete ▶

V1137889

 New X1 work tool
Name ▶



 New X1 work tool
Enter new name: —

V1137890

## 6 Setup

There are sub-items, "X1 work tool", "X3 Operation", "Auto idle time", "Anti-theft system", "Joystick shortkey", "Language", "Units", "Time/date", "Display light", and "Keypad backlight".

### ■ X1 work tool

This is to preset the X1 setting so that operators can use it simply by selecting the tool from the list.

**Enter password:** Enter the password to proceed with the setting for X1 tools. The password screen is displayed whenever the password is set using Volvo's service tool.

There are 3 sub-items which are,

- New
- Change
- Delete

Use the arrow buttons to place the cursor (highlighting bar) on the required item, and then press the SELECT button.

### New

The New setting is used to add new X1 tools. Follow the steps from 1 through 8, described below, to set and "Save" the parameters for the new attachment.

### NOTE!

If the "Save" procedure described in 8 is not performed, all settings are cancelled automatically.

- 1 Select "New" after entering "X1 work tool".
- 2 Name: Enter the name of the tool.
  - Use the arrow UP and arrow DOWN button to select the characters (A,B...Z,0,1...9).
  - Use the SELECT button to enter the selected character.
  - Press the SELECT button once again to save the name.
  - Use the ESC button to delete the entered character.

 New X1 work tool
Flow 280 l ▶



 New X1 work tool
Set flow: ◆ 280 l

V1137891

 New X1 work tool
Pressure 220 bar ▶



 New X1 work tool
Set pressure: ◆ 220 bar

V1137892

 New X1 work tool
Control Push ▶



 New X1 work tool
<input checked="" type="radio"/> Push
<input type="radio"/> Toggle
<input type="radio"/> Proportional

V1137893

- 3 Flow: Set the flow rate when this optional function is selected.
  - Select the preferred flow rate value using the arrow buttons.
  - Save the selected value using the SELECT button. Use the ESC button to cancel without saving.
  
- 4 Pressure: Set the pressure when this optional function is selected.
  - Select the preferred pressure value using the arrow buttons.
  - Save the selected value using the SELECT button. Use the ESC button to cancel without saving.
  
- 5 Control: Choose the control type.
  - Select the preferred control type using the arrow buttons.
  - Save the selected item using the SELECT button. Use ESC button to cancel without saving.

For information on control types, see page 79.

  - Push
  - Toggle
  - Proportional

 New X1 work tool
Pedal control Push ▶



 New X1 work tool
<input checked="" type="radio"/> Push
<input type="radio"/> Toggle
<input type="radio"/> Proportional

V1137894

 New X1 work tool
Attachment 1 way ▶



 New X1 work tool
<input checked="" type="radio"/> 1 way
<input type="radio"/> 2 way

V1137895

 New X1 work tool
Save

V1137896

- 6 Pedal control: Choose the pedal control type.
- Select the preferred control type using the arrow buttons.
  - Save the selected item using the SELECT button. Use ESC button to cancel without saving.

For information on control types, see page 79.

- Push
- Toggle
- Proportional

- 7 Attachment: Choose the 1 way or 2 way control.
- Select the preferred setting using the arrow buttons.
  - Save the selected item using the SELECT button. Use ESC button to cancel without saving.

- 8 Save: Save the setting.
- Select "Save" and press the SELECT button to save all settings including "Name", "Flow", "Pressure", "Control", "Pedal control", and "Attachment".

**NOTE!**

After entering the new settings, the "Save" procedure should be performed to record the new parameters in the system memory. If the "Save" procedure is not performed, all the settings will be cancelled automatically.

- If some items are not set up, the error message "Fill out all items" will appear.

- 9 The added X1 tool is newly listed.

 X1 work tool
Change ▶



 Change X1 work tool
<input type="radio"/> HAMMER
<input type="radio"/> SHEAR
<input checked="" type="radio"/> VOLVO

V1137897

 X1 work tool
Delete ▶



 Delete X1 work tool
<input checked="" type="radio"/> VOLVO



 Are you sure to delete?
Yes

V1140747

### Change

This is to modify the setting of preset X1 tools.

- 1 Select "Change" after entering "X1 work tool".
- 2 Select the tool to be modified using the arrow buttons and press the SELECT button.
- 3 Follow the same procedures from 2 to 8 explained in "New" section described above to change the setting.
- 4 There are some restrictions when modifying the setting:
  - The "Name" of two default X1 tools "HAMMER" and "SHEAR" are not modifiable.
  - The "HAMMER" can not be "2-way".
- 5 The modified X1 tool is listed.

### Delete

Use the arrow buttons to place the cursor (highlighting bar) on the required item, and then press the SELECT button.

To delete the preset "X1 work tool", proceed as follows :

- 1 Select "Delete" after entering "X1 work tool".
- 2 Select the tool to delete using the arrow buttons and press the SELECT button.

### NOTE!

Current preset X1 tool and default tools are not displayed.

- 3 Are you sure to delete?: Confirming message is displayed on the screen, press SELECT button to "Yes" or ESC button to "Cancel".

## 60 Instrument panels Display unit

 Setup
X3 operation ▶



 X3 operation
Enter password: * * * *



 X3 operation
Control: Push ▶



 X3 operation
<input checked="" type="radio"/> Push
<input type="radio"/> Toggle
<input type="radio"/> Proportional

V1140748

 Setup
Auto idle time ▶



 Auto idle time
Set auto idle time: ◆ 5 s

V1137900

### ■ X3 Operation

**Enter password:** Enter the password to proceed with the setting for X3 tools. The password screen is displayed whenever the password is set using Volvo's service tool.

Place the mark at the preferred item from the three listed with the arrow button.

When the SELECT button is pressed, the marked item is set. The screen reverts to the former screen displaying the newly selected item.

Refer to page 79 for more detailed information on control types.

### ■ Auto idle time

The basic concept of "Auto idle" is to reduce fuel consumption. The engine rpm will be lowered automatically to idle mode, if the Auto idle button is ON and any of control levers (pedals) or engine speed control switch are not operated for a certain time.

The operator can set Auto idle time from 3 seconds to 20 seconds.

■ **Anti-theft system:** See page 70 for information.

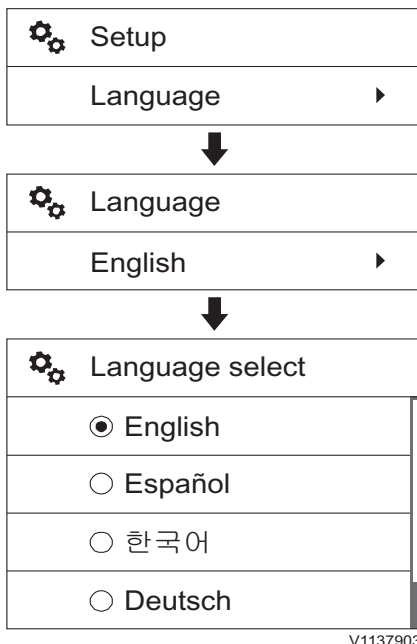
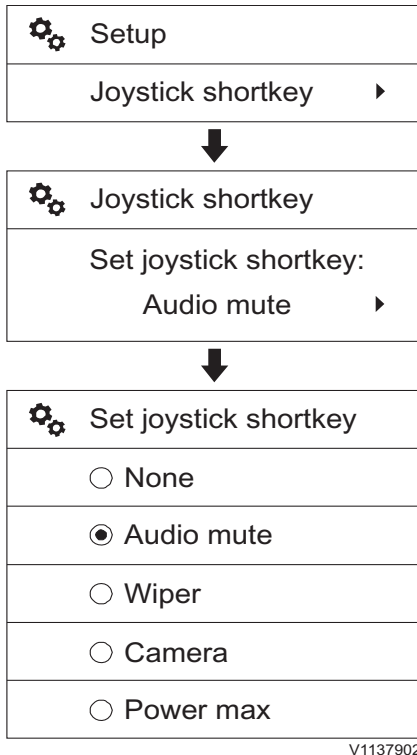

■ **Joystick shortkey:** Operator can use a function easily with a button of the left control lever. See page 96 for the position of the button. It also allows selection of a function from 5 different functions. The operator can select a function from 5 different functions with the arrow buttons. When pressing the SELECT button, the marked function is set. The screen reverts to the former screen displaying the name of the newly selected item. Also the selected item is displayed with a symbol on the IC (Instrument Cluster).

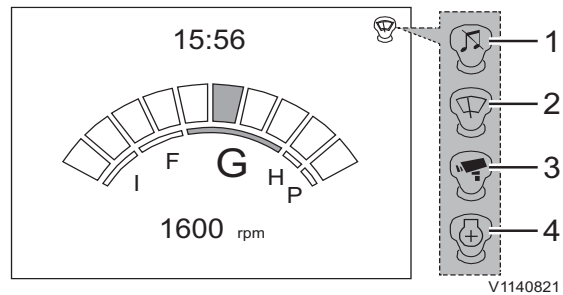

- 1 Audio mute
- 2 Wiper
- 3 Camera
- 4 Power max

■ **Language**

Supported languages are listed in the screen in the form of their own languages. Use the arrow buttons to scroll up and down to find your specific language. Press the SELECT button to select the chosen language. The screen reverts to the former screen displaying the newly selected language.



62 Instrument panels  
Display unit

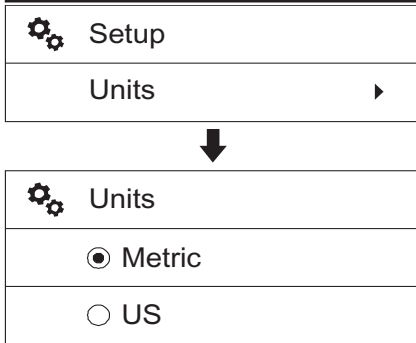

V1137904

■ Units

Two unit systems are displayed: "Metric" and "US". The operator can select one of the two using the arrow button and save it by pressing SELECT button.

The units stored in the IC (Instrument Cluster) are as follows;

Item	Metric	US
Time	h	h
Fluid rate	l/h	g/h
Volume	L	G
Voltage	V	V
Current	A	A
Temperature	°C	°F
Revolution	rpm	rpm
Speed	km/h	mph
Pressure	bar	psi
Distance	km	mile





⚙️ Setup
Time/date ▶



⚙️ Time/date
Date set 20140101 ▶



⚙️ Set date
yyymmdd: ⚡ 20140101

V1137905

⚙️ Time/date
Time set 12:30 ▶



⚙️ Set time
24h: ⚡ 12:30

V1137906

⚙️ Time/date
Date format yyymmdd ▶



⚙️ Date format
<input checked="" type="radio"/> yyymmdd
<input type="radio"/> mmddyyyy
<input type="radio"/> ddmmyyyy

V1137907

#### ■ Time/Date

- Date set: This is for adjusting the date. The preset date format is shown in the first row of the screen. The operator can adjust the date with arrow, ESC, and SELECT buttons. SELECT and ESC buttons are used to move ahead or go back with the cursor. Arrow buttons are used to adjust each segment of the date.
- Time set: This is for adjusting the time. The preset clock format is shown in the first row of the screen. The operator can adjust the time with arrow, ESC, and SELECT buttons. SELECT and ESC buttons are used move ahead or go back with the cursor. Arrow buttons are used to adjust each segment of the time.
- Date format: The items "yyymmdd", "mmddyyyy", and "ddmmyyyy" decide how the IC (Instrument Cluster) shows the date. "yyyy" means year, "mm" means month, and "dd" means day.

## 64 Instrument panels Display unit

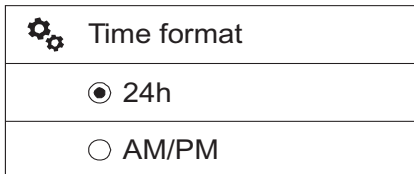
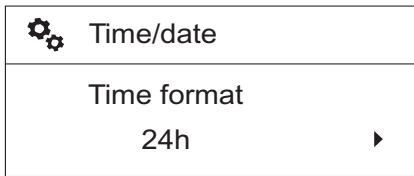

V1137908

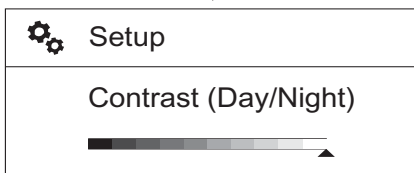
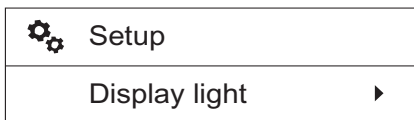

V1137909

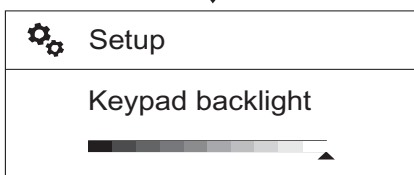
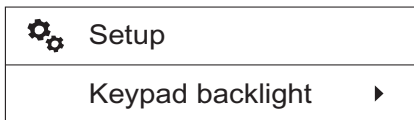

V1137910

- Time format: The items "24h" and "AM/PM" decide how the IC (Instrument Cluster) describes the time, 24-hour-system or 12-hour-system.

### ■ Display light

This is for changing the contrast of the IC (Instrument Cluster). The adjusting bar in the screen is controlled with the arrow buttons and the value is set with the SELECT button. The contrast is independently adjustable for day and night.

#### Contrast (Day/Night)

- When adjusting the "Contrast(Day)", the machine's work lights should be turned off.
- When adjusting the "Contrast(Night)", the machine's work lights should be turned on.

### ■ Keypad backlight

The brightness of the keypad backlight is changed by the adjustment. The adjusting bar in the screen is controlled with the arrow buttons and the value is set with the SELECT button.

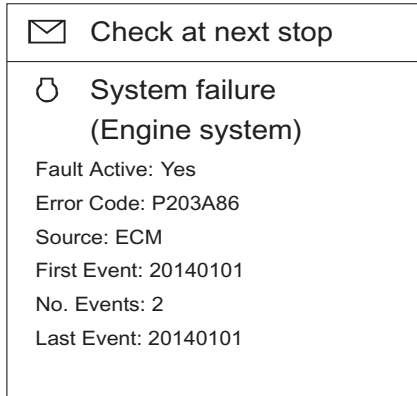
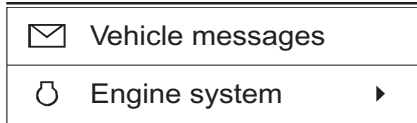

V1137911

## 7 Vehicle messages

This shows the headlines of messages. There are no errors or warning messages in normal operation.

If an abnormal condition is sensed, then the message will display the specific error/failure. Contact a workshop authorized by Volvo for advice, if needed.

When pressing the SELECT button to view detail information about a headline, the displayed information replaces the whole "main screen".

The information content includes;

- Fault Active
- Error Code
- Source
- First Event
- No. of events
- Last event

## Alarm texts

The information to the operator is provided on the display unit in the form of alarm texts, which are divided into three classes: Warning, Check and Information.

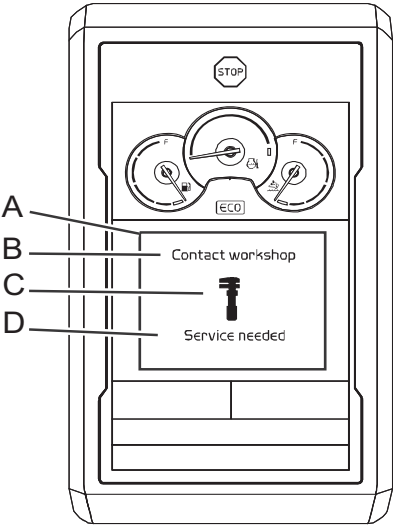
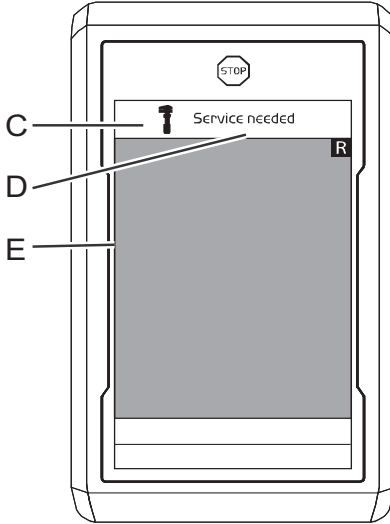
 <p><b>Warning (red)</b></p> <p>V1161686</p>		
<p><b>Alarm in main screen</b></p>  <p>V1208575</p>	<p><b>Alarm in camera screen</b></p>  <p>V1208576</p>	<ul style="list-style-type: none"> <li>- This screen is to warn the operator when the electronic system senses a machine malfunction or a safety related failure.</li> <li>- The red central warning symbol is shown.</li> <li>- The buzzer will sound until the required action has been performed.</li> <li>- The alarm text will be shown until the required action has been performed.</li> <li>- <b>Check the alarm text in a red box for the alarm reason and the required action.</b></li> <li>- Very time critical information/high priority or safety-related procedure. Immediate action needed.             <ol style="list-style-type: none"> <li>1 Stop the machine or operate equipment in a safe way as soon as possible.</li> <li>2 Perform a requested action before any operation.</li> <li>3 Turn off the engine if required.</li> </ol> </li> <li>- <b>Repair if possible or contact a qualified service technician.</b></li> </ul>
<p>A Information box (red)            B Text area for action            C Symbol area (red)            D Text area for reason or detail information            E Camera screen</p>		



Check (amber)

V1161687

Alarm in main screen

Alarm in camera screen

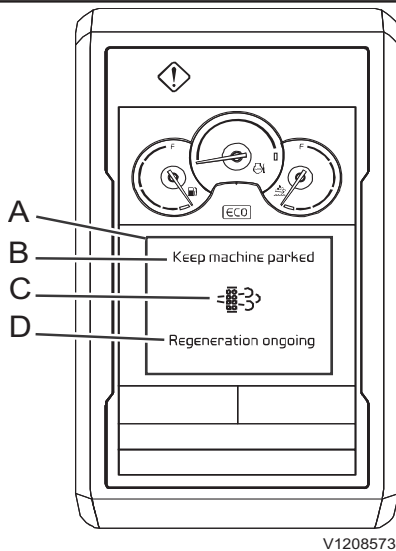

V1208573

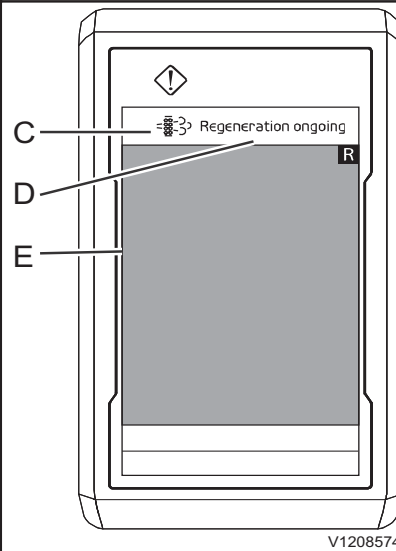

V1208574

- A Information box (amber)
- B Text area for action
- C Symbol area (amber)
- D Text area for reason or detail information
- E Camera screen

- This screen is to inform the operator when a partial failure of the machine is detected.
- The amber central caution symbol is shown.
- The buzzer sounds four times.
- Press SELECT button to obtain more information about the malfunction.
- Alarm text is shown until confirmation is performed by pressing ESC button.
- **Check the alarm text in a amber box for the alarm reason and the required action.**
- Medium time critical information/ medium priority.
- Need to be attention and/or further monitoring required but it is not necessary to stop the machine immediately.
- **Check the machine before next operation. Repair if possible or contact a qualified service technician.**

68 Instrument panels  
Display unit



Information (blue)

V1161688

Alarm in main screen	Alarm in camera screen	
<p>V1208571</p>	<p>V1208572</p>	<ul style="list-style-type: none"> <li>- This screen is to give useful information about the machine.</li> <li>- The blue central information symbol is shown.</li> <li>- The buzzer sounds two times.</li> <li>- The alarm text is shown for eight seconds and then changes to operating display or can be hidden immediately by pressing ESC button.</li> <li>- <b>Check the alarm text in a blue box for the alarm reason and the required action.</b></li> <li>- Low time critical information/low priority.</li> <li>- Need to be alerted, but active attention or system monitoring is not required.</li> <li>- <b>Check the machine before next operation. Repair if possible or contact a qualified service technician.</b></li> </ul>
<p>A Information box (blue)                  B Text area for action                  C Symbol area (blue)                  D Text area for reason or detail information                  E Camera screen</p>		

Result (white) / Function description (green)		
Alarm in main screen	Alarm in camera screen	<b>Result</b>
		<ul style="list-style-type: none"> <li>- Non-time critical information.</li> <li>- Presentation of result from selected action by operator.</li> <li>- Symbol and text message in a white box for result.</li> </ul>
<p><b>Function description</b></p> <ul style="list-style-type: none"> <li>- Can be used to provide help for the operator on activated functions.</li> <li>- Should be possible to activate/deactivate to avoid unnecessary disturbance for operator not requiring this.</li> <li>- Symbol and text message in a green box for function description.</li> </ul>		
<p>A Information box (white or green)            B Symbol area (optional) (white or green)            C Text area for result/function description (white or green)            D Camera screen</p>		

70 Instrument panels  
Display unit

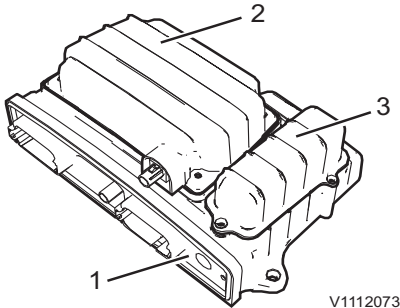

CareTrack unit

- 1 WECU
- 2 Satellite modem
- 3 Back-up battery

## CareTrack with anti-theft

### CareTrack with anti-theft (optional equipment)

CareTrack with anti-theft function works by WECU, web portal, Volvo's service tool (Tech Tool), GPMECU1, and IC (Instrument Cluster). The anti-theft function is to immobilize the machine according to the following conditions.

- Wrong code alarm
- Geofence broken
- Timefence broken
- System tampered
- Machine movement
- Battery power lost
- Remote immobilization
- No coverage
- ECU tampered

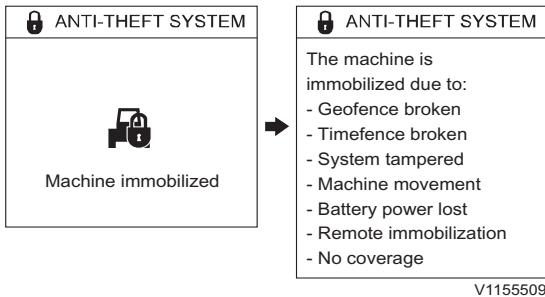

### Machine immobilized information

This screen is to warn the operator when the machine is immobilized. To get more information about the message on the screen, press the SELECT button. To go back to the previous screen, press the ESC button.

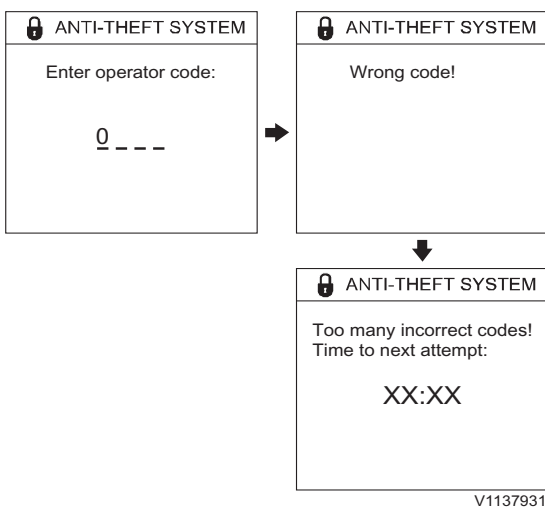

### Wrong code alarm

- When the machine is turned on, the authorization code display is shown if the anti-theft system is selected as an optional equipment. Wrong code display appears on the IC when the operator or machine owner has entered the wrong code. After 3 inputs of an incorrect code, the authorization will be limited for 5 minutes and a wrong code alarm will send to the CareTrack portal. The default code lock's delay time is 2 minutes and it can be changed with Volvo's service tool.

- Enter operator code
- Wrong code
- Too many incorrect codes
- Time to next attempt



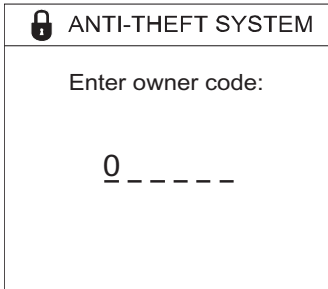

V1137932

Enter owner code

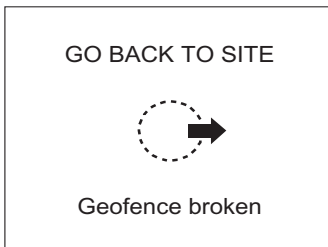

V1137933

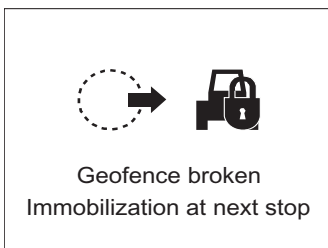

V1137934

**NOTE!**

When the delay time is shown, press and hold the SELECT button to enter the owner code.

- There are 3 levels for authorizing machine operation.
  - Level 1: This is the operator code with 4 digits which are set by the machine owner in IC menu or CareTrack portal.
  - Level 2: This is a machine owner PIN code with 6 digits which are set using Volvo's service tool.
  - Level 3: This is a one-time code with 8 digits which are obtained from the CareTrack portal.

**Geofence broken**

- When the machine owner activates a geofence in the CareTrack portal and the machine is outside the geofence, the geofence broken message will appear on the IC.
- When the machine owner activates a geofence and configures automatic immobilization in the CareTrack portal and the machine is outside the geofence, the geofence broken warning message will appear on the IC and the machine is immobilized at the next stop.
- WECU sends the warning message to the CareTrack portal.
- The warning condition is revoked when the machine is inside the geofence.

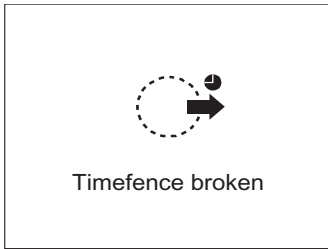

V1137935

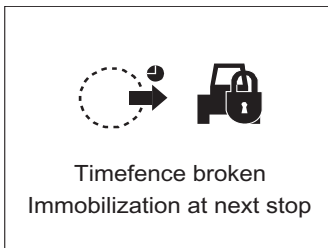

V1137936

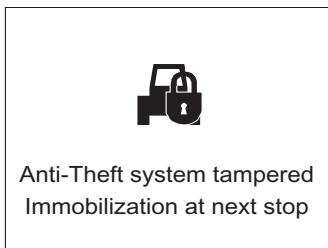

V1155538

### Timefence broken

- When the machine owner activates a timefence in the CareTrack portal and the machine is outside the timefence, the timefence broken message appears on the IC.

- When the machine owner activates a timefence and configures automatic immobilization in the CareTrack portal and the machine is outside the timefence, the timefence broken warning message appears on the IC and the machine is immobilized at the next stop.
- WECU sends the warning message to the CareTrack portal.
- The warning condition is revoked when the machine is inside the timefence.

### System tampered

#### ■ GPS tampered

- If the machine lost GPS antenna cable connection, the GPMECU1 informs the operator with the warning message on the IC and activates machine immobilization.

#### ■ GSM/3G tampered

- If someone cuts the GSM/3G antenna, the GPMECU1 informs the operator with the warning message on the IC and activates machine immobilization.

#### ■ Open box detection

- If someone tries to open the WECU enclosure, the GPMECU1 informs the operator with the warning message on the IC and activates machine immobilization.

#### ■ SIM card tampered

- If someone removes or changes the SIM card, the GPMECU1 informs the operator with the warning message on the IC and activates machine immobilization.

### NOTE!

WECU sends the warning message to the CareTrack portal.

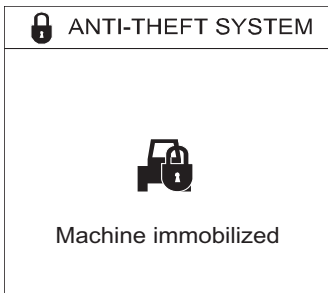

V1139556

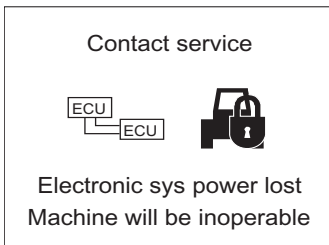

V1137938

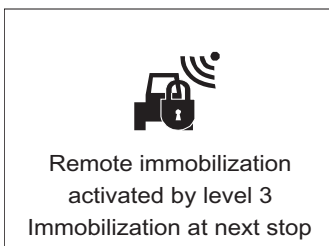

V1137939



V1137940

### Machine movement

- If the machine moves 100 metres without its own power, the WECU detects the machine movement and the machine will be immobilized and WECU sends the warning message to the CareTrack portal.
- After the machine has been immobilized, the warning message will appear on the IC before the authorization code display.
- The machine owner or dealer can mobilize (de-immobilize) the machine with codes for Level 2 and Level 3.

### Battery power lost

- If the WECU is disconnected from battery power cable or detects the battery supply voltage lower than 8 V, the WECU operates on its own internal battery.
- The GPMECU1 activates machine immobilization and the red warning message will appear on the IC.
- WECU sends the warning message to the CareTrack portal.
- The warning condition is revoked when the trigger has disappeared.

### Remote immobilization

- If dealer (level 3 code owner) requests machine immobilization in the CareTrack portal, the remote immobilization warning message will appear on the IC and the machine is immobilized at the next stop.
- If machine owner requests machine immobilization in the CareTrack portal, the remote immobilization warning message will appear on the IC and the machine is immobilized at the next stop.

## 74 Instrument panels Display unit



V1139554



V1137942

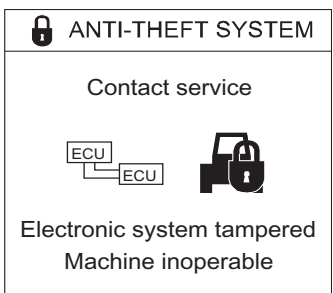

V1139558



V1155510

### No coverage

- If the WECU has not been connected to the CareTrack portal for the number of days set by Volvo's service tool, the machine will be immobilized.
- The no coverage days warning will appear at every start with number of remaining days set by Volvo's service tool.
- The active trigger and no coverage counter can be reset using a one-time code or Volvo's service tool.
- If the machine gets a connection to the CareTrack portal, the machine will be mobilized (de-immobilized) and the coverage counter is reset.

### ECU tampered

- When the machine is turned on, the WECU and GPMECU1 check the machine serial number of the other ECUs. If the machine's serial number is different, the GPMECU1 prevents machine start immediately and a warning message will appear on the IC.
- If the WECU is disconnected from key on cable and the machine is turned on, the GPMECU1 prevents machine start immediately and a warning message will appear on the IC.
- The warning condition is revoked when the trigger has disappeared.

### Anti-theft system, setup menu

This menu is used for setting up the anti-theft system. This menu is divided into two sub-menus as follows.

- 1 **Pin-code menu:** The machine owner's PIN code is required to access this menu. (6 digits)

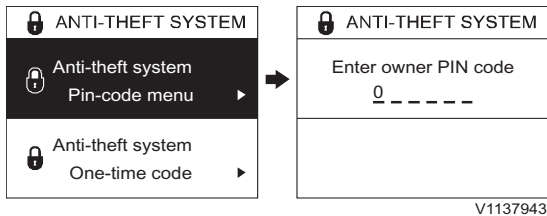

#### Enter owner PIN code

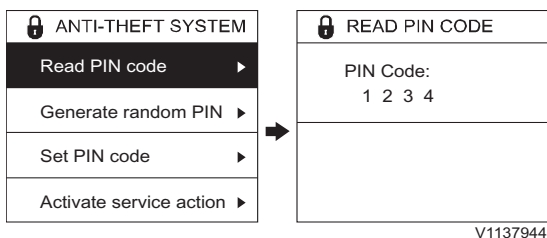

- **Read PIN code:** This sub-menu allows the machine owner to read the current PIN code. (4 digits)

#### PIN Code

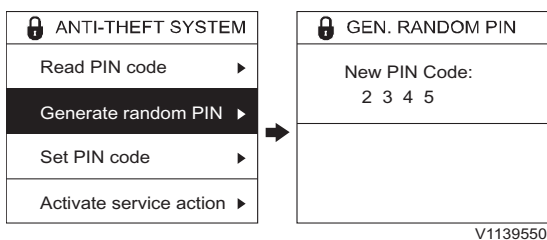

- **Generate random PIN:** This sub-menu allows the machine owner to generate a random PIN code. (4 digits)

#### New PIN Code

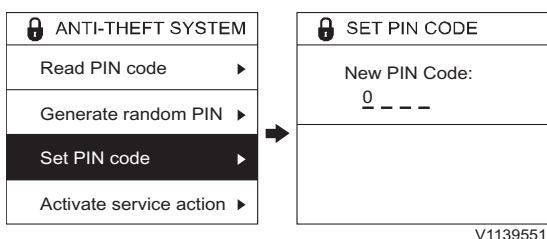

- **Set PIN code:** This sub-menu allows the machine owner to set a preferred PIN code. (4 digits)

#### New PIN Code

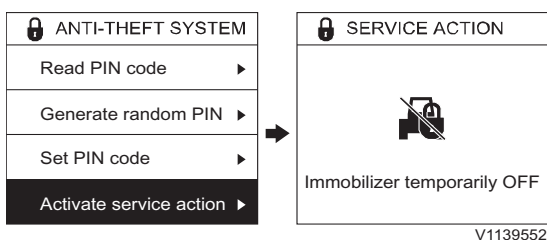

#### Immobilizer temporarily OFF

- **Activate service action:** This sub-menu is used for activating service actions such as moving the machine, replacing the machine battery and disconnecting the GPS antenna. This disables the anti-theft system except for remote immobilization, no coverage immobilization and machine serial number check, and the WECU informs the CareTrack portal. The anti-theft system will be activated when the ignition is turned on the next time.

## 76 Instrument panels Display unit

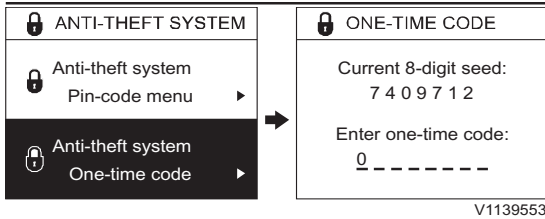

V1139553

Current 8-digit seed  
Enter one-time code

- 2 **One-time code:** This is used for setting a one-time code when the machine is immobilized with level 3 remote immobilization or no coverage warning condition.
- The machine owner gets the one-time code from the dealer. The dealer gets an 8-digit random code in the CareTrack portal with 8-digit seed (number shown on IC) and machine serial number.

### Alarm texts for anti-theft system

#### Information



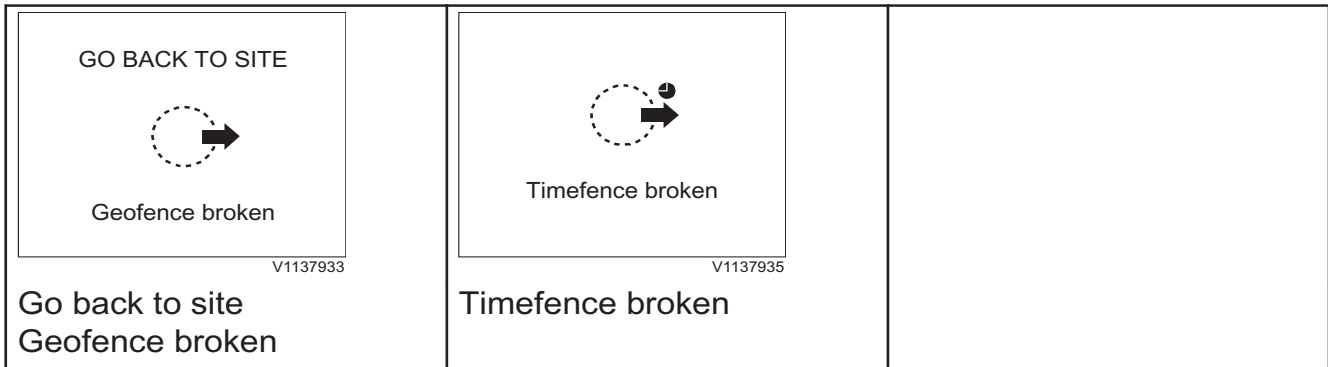



- The blue information symbol is shown.
- The buzzer sounds two times.
- Alarm text is shown for seven seconds and then changes to operating display.





**Check**

- The amber central warning symbol is shown.
- The buzzer sounds four times.
- Press SELECT button to obtain more information about the malfunction.
- Alarm text is shown until confirmation is performed by pressing ESC button.
- Repair or contact a workshop authorized by Volvo for information.

<div style="border: 1px solid black; padding: 10px; text-align: center;">             Geofence broken            Immobilization at next stop  <small>V1137934</small> </div> <p>Geofence broken Immobilization at next stop</p>	<div style="border: 1px solid black; padding: 10px; text-align: center;">             Timefence broken            Immobilization at next stop  <small>V1137936</small> </div> <p>Timefence broken Immobilization at next stop</p>	<div style="border: 1px solid black; padding: 10px; text-align: center;">             Anti-Theft system tampered            Immobilization at next stop  <small>V1155538</small> </div> <p>Anti-Theft system tampered Immobilization at next stop</p>
<div style="border: 1px solid black; padding: 10px; text-align: center;">             No coverage            Days before immob: XXX  <small>V1139554</small> </div> <p>No coverage Days before immob</p>	<div style="border: 1px solid black; padding: 10px; text-align: center;">             No coverage            Immobilization at next stop  <small>V1137942</small> </div> <p>No coverage Immobilization at next stop</p>	<div style="border: 1px solid black; padding: 10px; text-align: center;">             Remote immobilization            activated by level 3            Immobilization at next stop  <small>V1137939</small> </div> <p>Remote immobilization activated by level 3 Immobilization at next stop</p>
<div style="border: 1px solid black; padding: 10px; text-align: center;">             Remote immobilization            activated by owner            Immobilization at next stop  <small>V1137940</small> </div> <p>Remote immobilization activated by owner Immobilization at next stop</p>		

**Warning**

- The red central warning symbol is shown.
- The buzzer will sound until the required action has been performed.
- The alarm text will be shown until the required action has been performed.
- Repair or contact a workshop authorized by Volvo for information.

<p> ANTI-THEFT SYSTEM</p> <div style="border: 1px solid black; padding: 10px; text-align: center;"> <p>Machine immobilized</p> </div> <p style="text-align: right; font-size: small;">V1139556</p> <p>Machine immobilized</p>	<p> ANTI-THEFT SYSTEM</p> <p>The machine is immobilized due to:</p> <ul style="list-style-type: none"> <li>- Geofence broken</li> <li>- Timefence broken</li> <li>- System tampered</li> <li>- Machine movement</li> <li>- Battery power lost</li> <li>- Remote immobilization</li> <li>- No coverage</li> </ul> <p style="text-align: right; font-size: small;">V1155511</p> <ul style="list-style-type: none"> <li>- Geofence broken</li> <li>- Timefence broken</li> <li>- System tampered</li> <li>- Machine movement</li> <li>- Battery power lost</li> <li>- Remote immobilization</li> <li>- No coverage</li> </ul>	<p> ANTI-THEFT SYSTEM</p> <p>Contact service</p> <div style="border: 1px solid black; padding: 10px; text-align: center;"> <p>Electronic system tampered Machine inoperable</p> </div> <p style="text-align: right; font-size: small;">V1139558</p> <p>Contact service Electronic system tampered Machine inoperable</p>
<p> ANTI-THEFT SYSTEM</p> <p>Contact service</p> <div style="border: 1px solid black; padding: 10px; text-align: center;"> <p>Anti-Theft system tampered Machine immobilized</p> </div> <p style="text-align: right; font-size: small;">V1155510</p> <p>Contact service Anti-Theft system tampered Machine immobilized</p>	<p>Contact service</p> <div style="border: 1px solid black; padding: 10px; text-align: center;"> <p>Electronic sys power lost Machine will be inoperable</p> </div> <p style="text-align: right; font-size: small;">V1137938</p> <p>Contact service Electronic sys power lost Machine will be inoperable</p>	



New X1 work tool
<input checked="" type="radio"/> Push
<input type="radio"/> Toggle
<input type="radio"/> Proportional

V1137912

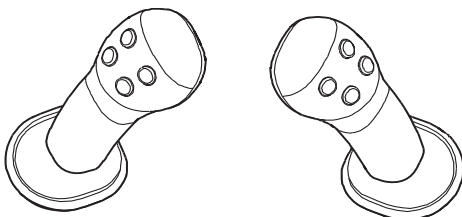

V1065552

Control lever with on/off switch

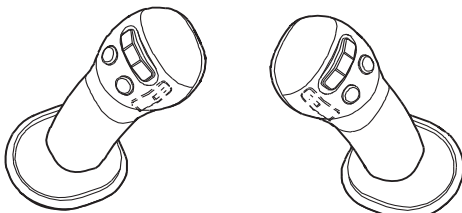

V1065553

Control lever with proportional switch

## Control types for X1 and X3 operation

If a machine has a "proportional control option" for X1 or X3, the user can set one of these 3 types. Otherwise the user is only allowed to set one of 2 types that are "Push" or "Toggle". Refer to page 96 for more details on optional levers.

- Push
- Toggle
- Proportional

### Control using on/off switch on the control lever

- 1 Toggle type in the IC (Instrument Cluster)  
Actuator for X1 or X3 is activated by pressing the on/off switch on the control lever and it will stay active even when the switch is released. The actuator will be deactivated when the same switch is pressed again or the other switch for opposite direction is pressed.
- 2 Push type in the IC (Instrument Cluster)  
Actuator for X1 or X3 is activated while the on/off switch is pressed (On position). The function will be deactivated when the on/off switch is released.

### Control using proportional switch on the control lever

- 1 Toggle and Push-button type in the IC (Instrument Cluster)  
These controls with proportional switch are similar as the ones with on/off switch but it has a special point to activate the actuator because the proportional switch also has a proportional value.  
In toggle type, the actuator will be activated by moving the proportional switch to one direction and it will be deactivated when the switch is moved to same direction again or to opposite direction.
- 2 Proportional type in the IC (Instrument Cluster)  
Actuator for X1 or X3 is activated proportional to the movement of the proportional switch.

## Instrument panel, right

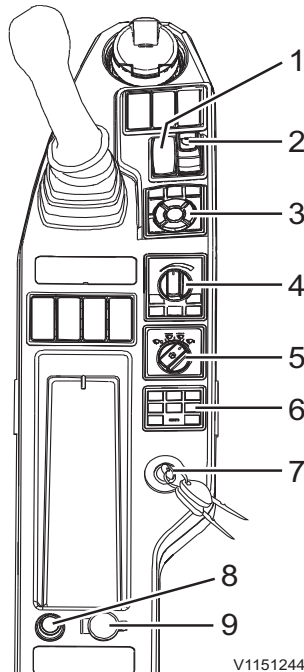

V1151244

- 1 Travel speed switch
- 2 Attachment quick coupler switch, right (optional equipment)
- 3 IC (Instrument Cluster) control keypad
- 4 Machine control keypad
- 5 Wiper and washer control switch
- 6 Audio remote control switch with Bluetooth
- 7 Ignition switch
- 8 Cigarette lighter (optional equipment)
- 9 Power socket

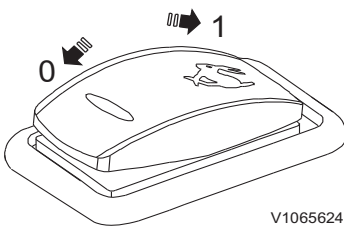

V1065624

### 1 Travel speed switch

- Position 0: Travel at LOW speed only
- Position 1: Travel at LOW or HIGH by automatic shift according to travel condition

#### NOTE!

Stop the machine before selecting a different travel speed. Low speed should be selected for grades, on soft ground, in restricted spaces, and when the machine is loaded onto or unloaded from a transport vehicle.

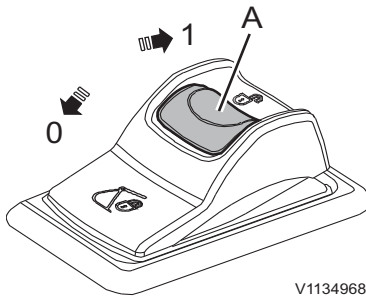

A Lock device

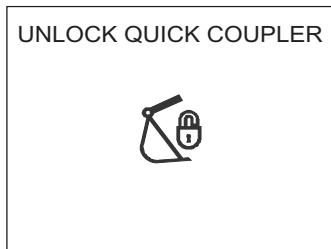

V1147253

Unlock quick coupler

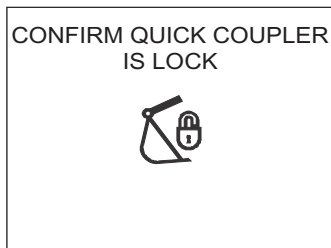

V1147255

Confirm quick coupler is locked

## 2 Attachment quick coupler switch, right (optional equipment)

- Position 0: Attachment quick coupler, lock control
- Position 1: Attachment quick coupler, initiating control

Press down to release the red lock device (A) and then press the switch to position (1) to initiate the attachment quick coupler.

When the attachment quick coupler is initiated, the buzzer sounds and the check message and indicator are displayed on the IC (Instrument Cluster).

### NOTE!

The attachment quick coupler switch for activation on the left instrument panel must be pressed to open the attachment quick coupler. See page 36 for operation.

After installing the attachment quick coupler, press the switch to position (0) to close the attachment quick coupler. When the switch is in position (0), the buzzer sounds and the check message for confirming and indicator are displayed on the IC (Instrument Cluster).

### NOTE!

Press the attachment quick coupler switch on the left instrument panel to confirm that the attachment quick coupler is locked. See page 36 for the operation.

82 Instrument panels  
Instrument panel, right

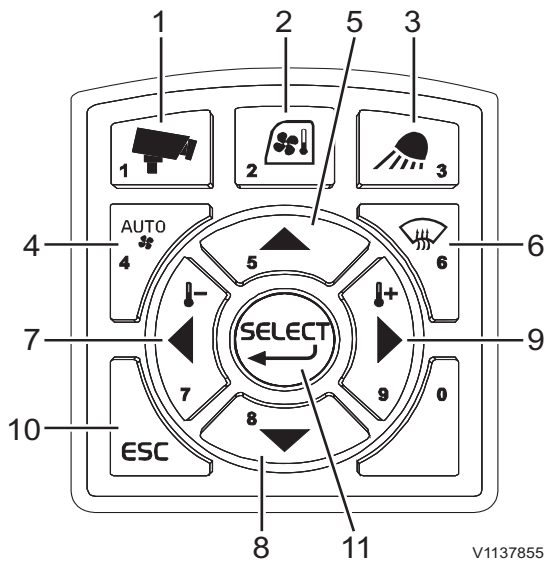

V1137855

- 1 Camera button
- 2 HVAC control button
- 3 Work lights control button
- 4 HVAC auto-mode select button
- 5 Arrow up button
- 6 Defroster select button
- 7 Arrow left button
- 8 Arrow down button
- 9 Arrow right button
- 10 ESC button
- 11 SELECT button

**3 IC (Instrument Cluster) control keypad**

**1) Camera button (if installed)**

This button is used to control the camera screen in the IC (Instrument Cluster).

- A short press on the camera button shows the camera view with the gauges at the top of the screen.
- A long press on the camera button shows the camera configuration bar. For detailed information about camera control, see page 130.

**2) HVAC control button**

This button is used to control the HVAC system. See page 117.

**3) Work lights control button**

This button is used to control the work lights on the boom, cab, deck, and counterweight.

- Press the button short to turn on or off the work lights. All settings remain if the system is turned off.
- Press and hold in the button to set the work lights. Use the arrow buttons to select the required work light, and then press the SELECT button on the IC control keypad to turn on or off the work light. When selecting "All", all work lights are turned on or off.

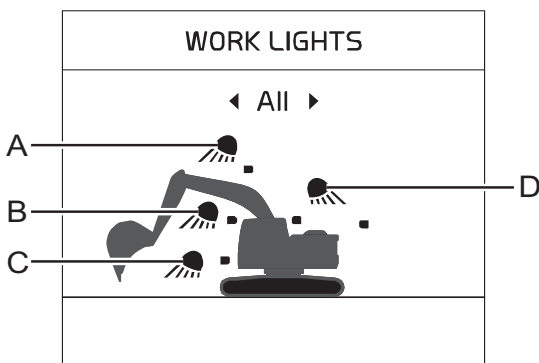

V1155429

- A Boom work light
- B Cab front light
- C Deck work light
- D Cab rear and counterweight lights

**4) HVAC auto-mode select button**

This button is used to control the HVAC system. See page 117.

**5) Arrow up button**

This button is used to scroll between items and adjust each segment on the screen.

**6) Defroster select button**

This button is used to activate the defroster. See page 117.

**7) Arrow left button**

This button is used to move the cursor to the left. Also press the button in order to decrease values.

**8) Arrow down button**

This button is used to scroll between items and adjust each segment on the screen.

**9) Arrow right button**

This button is used to move the cursor to the right. Also press the button in order to increase values.

**10) ESC button**

This button is used to go back to the previous screen or to cancel without saving. The ESC button is also used to turn off the warning light and sound.

**11) Select button**

This button is used to confirm the item or setup that the user selects.

## 84 Instrument panels Instrument panel, right

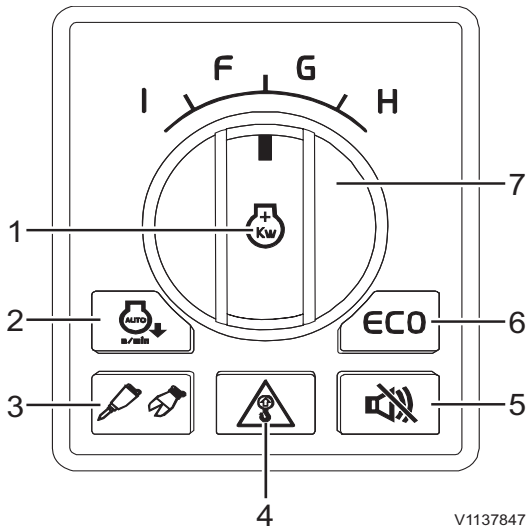

- 1 Power max. mode switch
- 2 Auto idle button
- 3 Hammer/Shear button
- 4 Overload warning button
- 5 Travel alarm stop button
- 6 ECO button
- 7 Engine speed/Work mode control switch

### 4 Machine control keypad

#### 1) Power max. mode switch

Press down this switch to activate power maximum mode.

#### At step 9 of the engine speed control switch,

Normal condition = H-mode

Press down the switch = P-mode

If the machine is not operated in P-mode for more than 5 seconds and the auto idle selector switch is activated, the engine speed automatically goes down to idle mode. When the machine is operated again, it returns to P-mode again. In P-mode, it becomes H-mode if step 9 is selected after turning the engine speed control switch to another step.

#### 2) Auto idle button

Auto idle button activates or deactivates "Auto idle" function of the GPMECU1 (General Purpose Machine Electronic Control Unit1).

The engine speed will be reduced automatically to idle in order to reduce fuel consumption if any of control levers, travel levers (pedals) or engine speed control switch are not operated for 5 seconds. If any one of the above is operated, the engine speed returns to the speed set with the engine speed control switch.

#### 3) Hammer/Shear button

This button is used to activate the hammer/shear function.

Before operating the functions below, the hammer/shear button should be activated.

#### NOTE!

This instruction can be changed according to the types of operating lever. For more information about operating levers, see page 96.

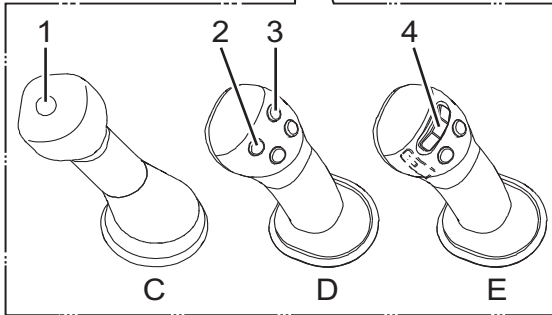
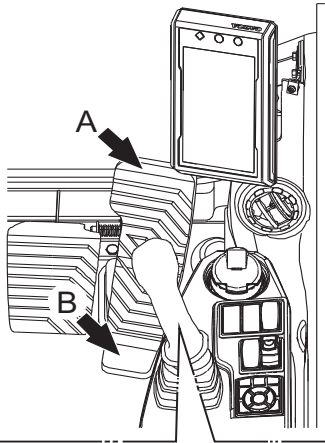

V1137128

**NOTE!**

Select the X1 work tool on the IC (Instrument Cluster), see page 44 for details.

**If a pedal is provided with X1 option (hammer/shear)**

The pedal should be adjusted if it is used for hammer or shear. Refer to page 96 for details.

■ Hammer mode

Hammer will work when the pedal is pressed forward (A).

■ Shear mode

Shear will work when the pedal is pressed forward (A) or backward (B).

**If control lever with one button (C) is installed**

■ Hammer mode

Hammer will work when button (1) is pressed.

**NOTE!**

When the hammer/shear function is not activated if this button is pressed, the power boost will be activated.

**If control lever with four buttons (D) is installed**

■ Hammer mode

Hammer will work when button (2) is pressed.

**NOTE!**

There will be no response when button (3) is pressed.

■ Shear mode

Shear will work when button (2) or (3) is pressed.

**If control lever with proportional switch (E) is installed**

■ Hammer mode

Hammer will work when proportional switch (4) is moved to left side.

**NOTE!**

There will be no response when the proportional switch is moved to right side.

■ Shear mode

Shear will work when proportional switch (4) is moved to left or right side.

#### 4) Overload warning button

Overload warning button activates or deactivates "Overload warning" function. This button is to display a symbol and to generate an alarm if the "overload signal" is detected.

- First event of overloading: The pop-up message will be displayed and a warning alarm sounds. The warning indicator is also shown on indicator screen. The pop-up message will disappear only when the ESC button is pressed.
- When the event occurs again when operating the machine: A warning alarm sounds and the indicator is shown. When reducing the load, the alarm and indicator will turn off.

#### 5) Travel alarm stop button

Travel alarm stop button is used to activate or deactivate "Travel alarm" function of the GPMECU1 (General Purpose Machine Electronic Control Unit1). "Travel alarm" function is activated whenever the ignition switch is on.

#### NOTE!

When starting the machine travel, the travel alarm always sounds for 5 seconds even though the travel alarm stop function is activated.

#### 6) ECO button

ECO function is a mode for fuel economy when working with the machine.

When pressing the ECO button on the keypad, then pump control works for fuel economy. The button will light up and also an ECO symbol is shown on the IC (Instrument Cluster) when activated. Press the button again to disable the function and the button light and symbol on the IC will turn off.

#### NOTE!

When the ignition switch is on, ECO mode is always activated automatically. (except North America region)

#### NOTE!

This mode is only available for P-, H-, G1-, G2-, G3-, and G4-mode of the engine speed/work mode control switch.

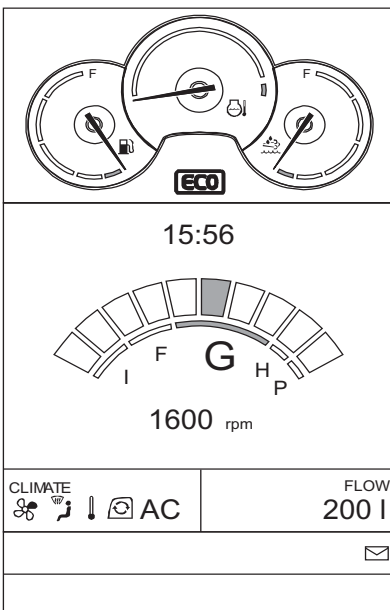

V1137848



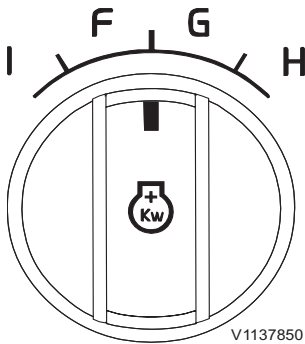

V1137850

**7) Engine speed/Work mode control switch**

Nine (ten in cases where P-mode is used) different throttle positions are available through the control of this switch. Turning this switch, the engine speed will change incrementally. According to the selected engine speed, work mode will be set automatically and setting mode is displayed on the main screen in the front instrument panel.

**With P mode**

Switch step	Mode			Engine speed (no load/load) (±40 rpm)	Remarks
	Power max.	P	Normal ECO		
9	Power max.	P	Normal	1900 / 1800	For maximum productivity during hard digging and trenching
			ECO		
	Heavy	H	Normal	1800 / 1700	For moderately hard operations
			ECO	1800 / 1615	
8	General	G1	Normal	1700 / 1600	For economical operation during general applications
			ECO	1700 / 1520	
7		G2	Normal	1600 / 1500	
			ECO	1600 / 1425	
6		G3	Normal	1500 / 1400	
			ECO	1500 / 1330	
5		G4	Normal	1400 / 1300	
			ECO	1400 / 1235	
4	Fine	F1	Normal	1300 / 1200	For Maximum lifting power and moderate control
3		F2	Normal	1200 / 1100	
2	Idle	I1	Normal	1000 / 900	For low idle, warm-up, and high-precision operation
1		I2	Normal	800 / 700	



88 Instrument panels  
Instrument panel, right

Without P mode

Switch step	Mode			Engine speed (no load/load) (±40 rpm)	Remarks
9	Heavy	H	Normal	1900 / 1800	For maximum productivity during hard digging and trenching
			ECO		
8	General	G1	Normal	1800 / 1700	For economical operation during general applications
			ECO	1800 / 1615	
7		G2	Normal	1700 / 1600	
			ECO	1700 / 1520	
6		G3	Normal	1600 / 1500	
			ECO	1600 / 1425	
5		G4	Normal	1400 / 1300	
			ECO	1400 / 1235	
4	Fine	F1	Normal	1300 / 1200	For Maximum lifting power and moderate control
3		F2	Normal	1200 / 1100	
2	Idle	I1	Normal	1000 / 900	For low idle, warm-up, and high-precision operation
1		I2	Normal	800 / 700	

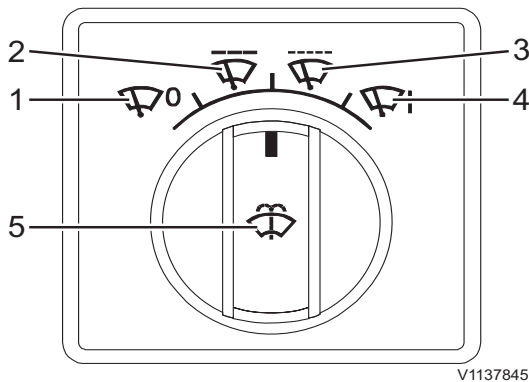

## 5 Wiper and washer control switch

Turn the wiper and washer control switch to the desired position.

### 1) Wiper off

2) Wiper interval 1: After one operation, off for 5 seconds

3) Wiper interval 2: After one operation, off for 2 seconds

### 4) Wiper continuous

5) Washer: Press down this switch to work the washer

## NOTICE

Do not keep the washer switch pressed in for more than 20 seconds. Do not use the washer, if the reservoir for washer fluid is empty.

## NOTE!

When using the joystick shortkey;

- Press the joystick shortkey button briefly on the left control lever for the wiper operation.
- Keep pressing the button for the wiper and washer operation.

90 Instrument panels  
Instrument panel, right

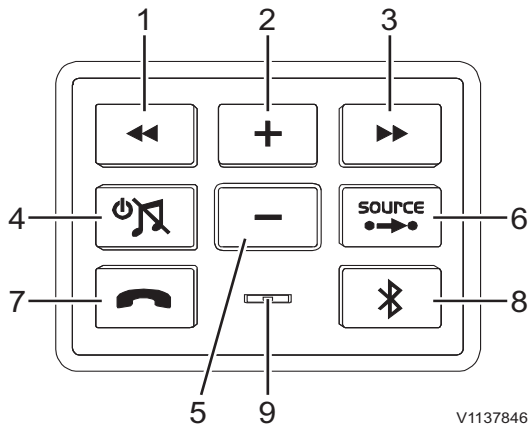

- 1 Auto-select channel button (downward)  
Music select button (backward)
- 2 Volume up button
- 3 Auto-select channel button (upward)  
Music select button (forward)
- 4 Power on/off, Mute toggle button
- 5 Volume down button
- 6 Source change button
- 7 Call button
- 8 Bluetooth button
- 9 Call mic

**6 Audio remote control switch with Bluetooth**

**1) Auto-select channel button (downward)**

Press the button to search channels automatically. It searches the lower frequencies automatically and stops at a receivable frequency.

**Music select button (backward)**

It selects the previous song in the play list in your cell phone.

When music plays for more than 1 second, it turns back to the start of the song, and if you press the button again, it returns to the previous song.

**2) Volume up button**

Press the button to increase the volume. Keep pressing it to increase volume gradually.

**3) Auto-select channel button (upward)**

Press the button to search channels automatically. It searches the higher frequencies automatically and stops at a receivable frequency.

**Music select button (forward)**

It selects the next song in the play list in your cell phone.

**4) Power on/off, Mute toggle button**

Press the button to turn On/Off the audio power and to change between Mute/Output.

- Press shortly → Mute/Press shortly → Unmute
- Keep pressing the button → Power off

**5) Volume down button**

Press the button to reduce volume. Keep pressing it to reduce the volume gradually.



**6) Source change button**

By pressing the FM/AM button, the radio starts and radio modes change (RADIO/USB/AUX).

By pressing this button, you can change the source of music played by the audio system. When you press this button in Bluetooth mode, it changes into Connected Audio Control Mode.

**7) Call button**

Press Bluetooth (connected audio control mode) button for actions related to calls, including calling/hanging up/answering/rejecting.

When the phone rings, this button flashes green, and during a conversation, the light is on with fixed green.

- Not calling: Calling
- In calling: Hanging-up
- Flashing (phone ringing): Answering
- Keep pressing the button while flashing: Rejecting
- Call function of the button above calls the previous number

**8) Bluetooth button**

By pressing this button, the following functions will work according to the machine's Bluetooth connection status.

- Not connected: Requesting connection to the previously connected device
- Connected: Change to Bluetooth mode
- Keep pressing the button when connected: Disconnect Bluetooth

**9) Call mic**

When you talk using a hands-free device, you can transmit a voice with this mic.

92 Instrument panels  
Instrument panel, right

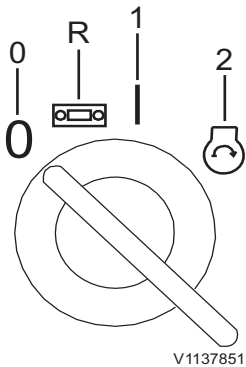

- OFF position (0)
- Radio position (R)
- Operating (preheating) position (1)
- Start position (2)

## 7 Ignition switch

This ignition switch has four positions. Make sure to activate the battery disconnect switch before trying to start engine.

### OFF position (0)

Turn the ignition switch to position (0) to turn off engine.

### Radio position (R)

Turn the ignition switch to position (R) to turn on the radio.

### Operating (preheating) position (1)

The machine is equipped with an automatic engine preheating system. When the ignition switch is turned to position (1), the vehicle's electronic system will be active, thus activating the automatic engine preheating system.

### Start position (2)

When the ignition switch is turned to position (2) the starter motor will be engaged to crank the engine, provided that the battery disconnect switch has been activated. The starter motor will not crank as long as the control lockout lever is in unlocked (up) position. Refer to page 111 for details on the control lockout lever.

## Instrument panels Instrument panel, right

93

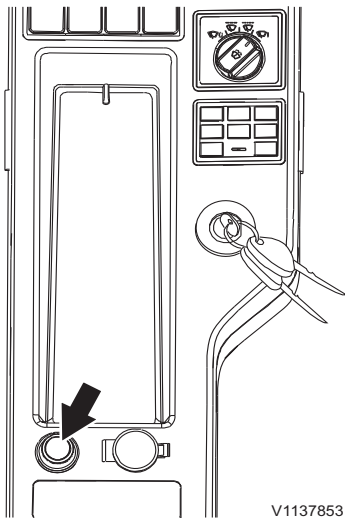

### 8 Cigarette lighter (optional equipment)

Press it down, and in a few seconds it will return to original position. At this time it is ready to use (24 V).

#### **NOTICE**

The voltage in the cigarette lighter socket is 24 V. Therefore, do not connect any 12 V appliances.

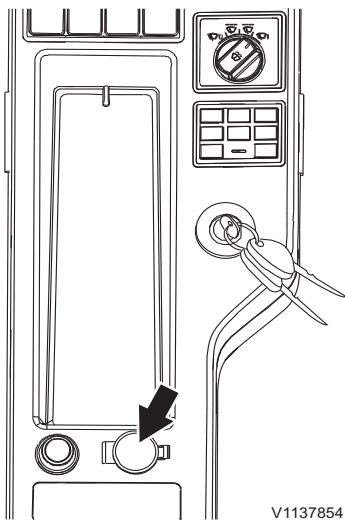

### 9 Power socket

This socket is for electrical appliances such as a mobile phone charger. Capacity: under 12 V (10 A)

94 Instrument panels  
Instrument panel, rear

Instrument panel, rear

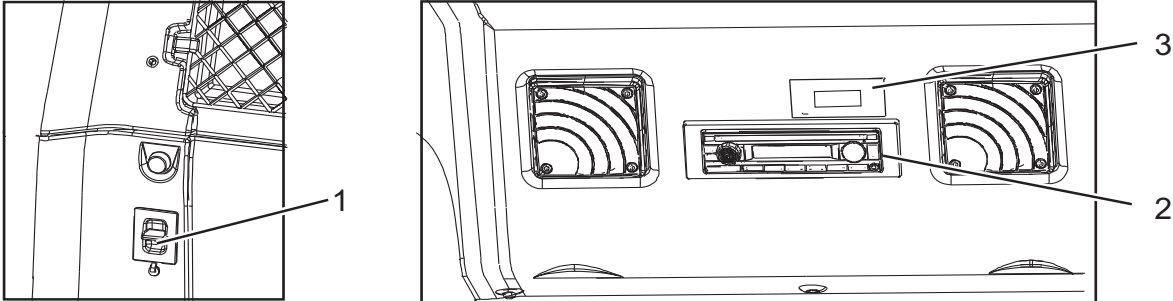

V1151245

- 1 Service socket
- 2 Audio system (optional equipment)
- 3 Auxiliary heater (optional equipment)

**1 Service socket**

This socket is for Volvo's service tools (MATRIS and Tech Tool).

**2 Audio system (optional equipment)**

See page 126.

**3 Auxiliary heater (optional equipment)**

See page 135.



## Other controls

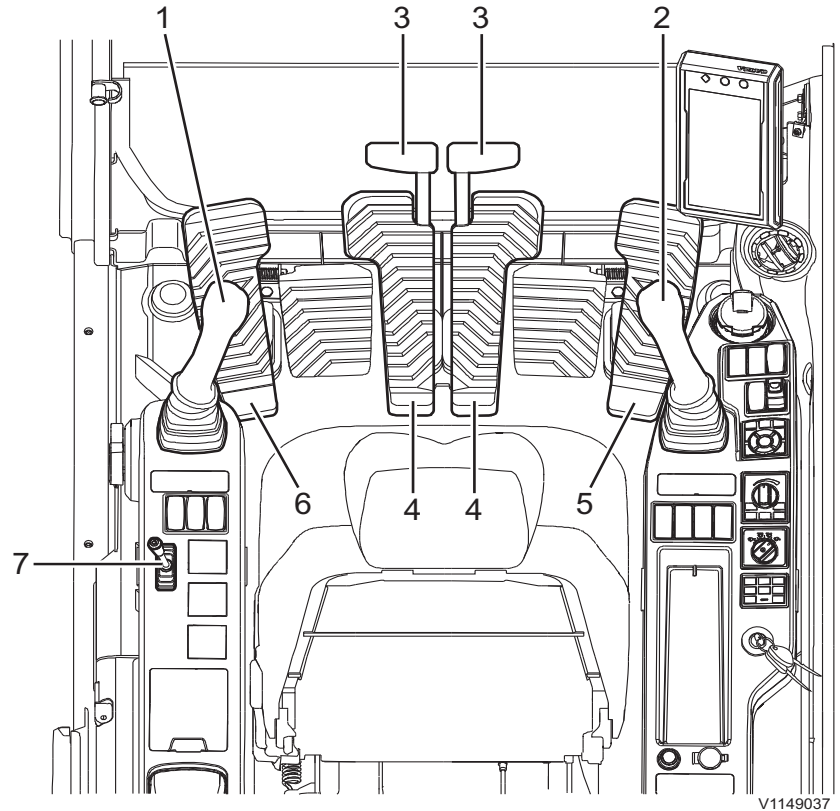

V1149037

1	Left control lever
2	Right control lever
3	Travel levers
4	Travel pedals
5	Optional pedal (X1)
6	Optional pedal (Straight travel) Optional pedal (Variable adjustable boom)
7	Dozer blade lever

The control levers of this machine is set from factory to operate in ISO/SAE standard operating pattern for optimum machine performance.

Some machines may have the optional pattern change valve. Refer to page 96 for more details.

On machines equipped with the optional pattern change valve, the indicator of chosen pattern will be shown on the IC (Instrument Cluster).

## Controls

### 1 Left control lever

This lever is for swing superstructure and moving dipper arm.

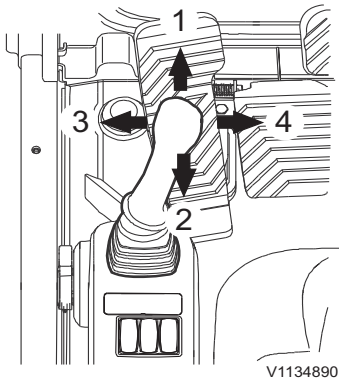

- 1 Dipper arm out
- 2 Dipper arm in
- 3 Left swing
- 4 Right swing

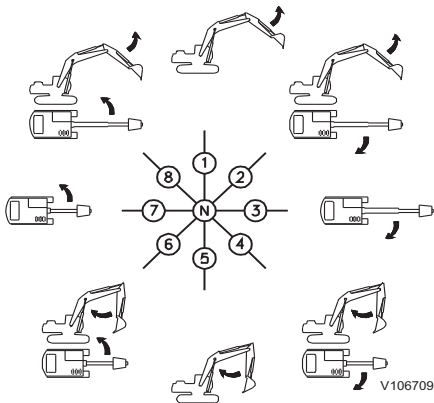

- N Neutral (superstructure and dipper arm in neutral position)
- 1 Dipper arm out
- 2 Dipper arm out and swing superstructure right
- 3 Swing superstructure right
- 4 Dipper arm in and swing superstructure right
- 5 Dipper arm in
- 6 Dipper arm in and swing superstructure left
- 7 Swing superstructure left
- 8 Dipper arm out and swing superstructure left

## 2 Right control lever

This lever is for moving boom and bucket.

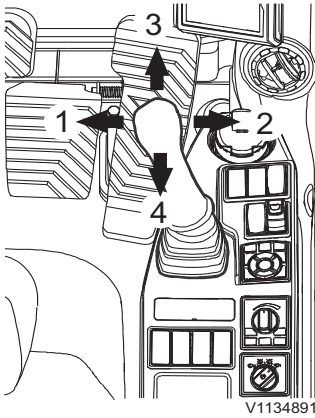

- 1 Bucket in
- 2 Bucket out
- 3 Boom lower
- 4 Boom raise

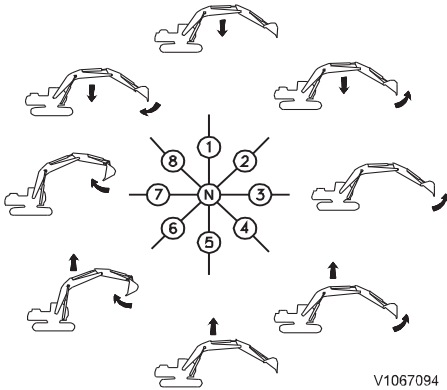

- N Neutral (boom and bucket are maintained at rest position)
- 1 Lower boom
- 2 Lower boom and bucket out
- 3 Bucket out
- 4 Raise boom and bucket out
- 5 Raise boom
- 6 Raise boom and bucket in
- 7 Bucket in
- 8 Lower boom and bucket in

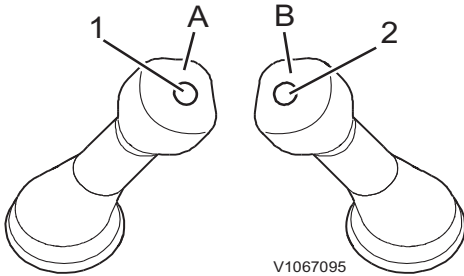

**Control lever with one button**

- A Left operating lever
- B Right operating lever
- 1 Horn button
- 2 Boost/hammer button

**NOTE!**

When the hammer select switch is activated, the boost function does not work.

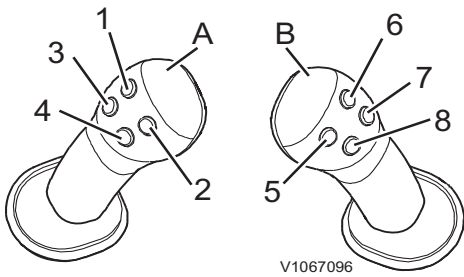

**Control lever with four buttons**

- A Left operating lever
- B Right operating lever
- 1 Rotator button
- 2 Rotator button
- 3 Horn button
- 4 Joystick shortkey button
- 5 Hammer/shear button
- 6 Shear/unassigned
- 7 Float button
- 8 Boost button

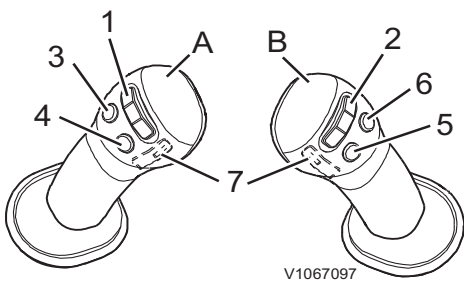

**Control lever with three buttons and proportional switch**

- A Left operating lever
- B Right operating lever
- 1 Proportional switch (rotator)
- 2 Proportional switch (hammer/shear)
- 3 Horn button
- 4 Joystick shortkey button
- 5 Boost button
- 6 Float button
- 7 Unassigned

**NOTE!**

Before operating the control levers for X1 or X3 operation, make sure to read and understand the different control types for the different buttons and switches, refer to page 79 for details.

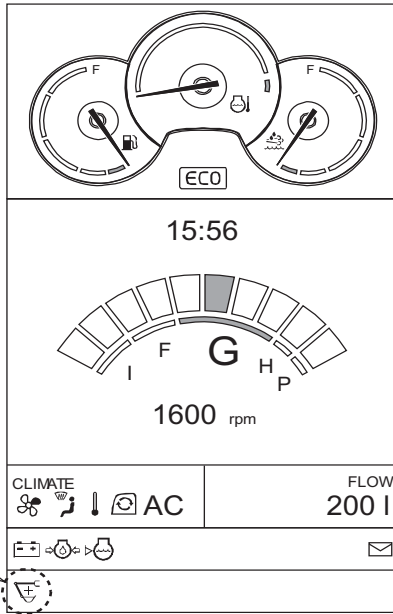

V1134892

Indicator for power boost

### Power boost function

The power boost is designed to increase dipper arm / bucket forces, and lifting capacities. When digging in P, H or G modes in extremely hard digging conditions, it is recommended to press the power boost button before starting the digging cycle.

Digging force will be increased for 9 seconds, which is sufficient time for the operator to load the bucket. After the 9-second period, the power boost is turned off automatically.

The power boost indicator is shown on the indicator screen of IC (Instrument Cluster) whenever it is activated. In F-mode, the power boost is activated continuously for maximum lifting capacity.

100 Other controls  
Controls

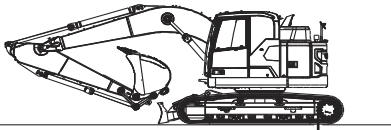

A V1152381

A Sprocket

3 Travel levers

4 Travel pedals

These are used to move and stop the machine.

**NOTICE**

In this Operator's Manual front, forward, rear, rearward, right and left are based on the premiss that the sprockets are placed behind the cab. Pay attention to this before control levers and pedals are used.

If you want to travel the machine continuously, keep in mind below operating conditions.

Ground conditions	Operation
Flat, normal or soft soil	Do not travel continuously for more than 2 hours. If you want to travel for more than 2 hours at high speed, stop for more than 20 minutes. Otherwise, track rollers and idlers could be overheated and lead to oil leakage. <b>NOTE!</b> Travel the machine to forward direction (to idler side) to reduce wear to moving parts of the undercarriage.
Uneven or tough soil (mixed of gravels, stones, boulders, other obstacles or on a slope)	Travel the machine at low speed and do not travel continuously for more than 1 hour. If you want to travel for more than 1 hour, stop for more than 20 minutes. Otherwise, track rollers and idlers could be overheated and lead to oil leakage. <b>NOTE!</b> Travel the machine to forward direction (to idler side) to reduce wear to moving parts of the undercarriage.

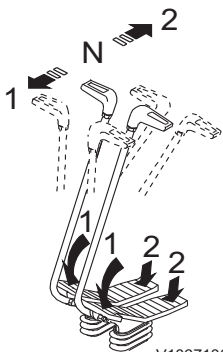

V1067100

N Neutral (machine stops)

- 1 Forward Push the lever forward or press down front end of the pedal to advance the machine, when the sprocket is at the rear of the machine.
- 2 Reverse Pull the lever rearward or press down rear end of the pedal to reverse the machine, when the sprocket is at the rear of the machine.

**NOTE!**

When the sprockets are at the front side of the machine, the machine will be moved to the opposite direction as to above.

- The distance the travel levers/pedals are pulled or pushed determines the travel speed of the machine. That is, if the levers/pedals are pushed or pulled fully, the machine will travel at the maximum speed, provided that the high travel speed has been selected and the engine RPM is at full throttle position.
- The machine brakes are engaged automatically when the travel controls are moved to the neutral position. To reduce the travel speed, slowly return the travel controls to the center (neutral) position.
- In cold weather, the travel function may be heavier than normal due to the oil viscosity.

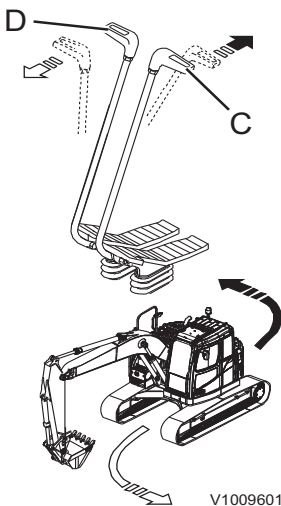

**Left turn**

- 1 When the sprockets are at the rear side of the machine Push the right lever (D) forward, the RH track rotates forward and the machine travels forward as it turns to the left.  
Pull the left lever (C) backward, the LH track rotates in reverse and the machine travels backward as it turns to the left.
- 2 When the sprocket is at the front side of the machine Operate levers (C or D) in the opposite direction as to above.

102 Other controls  
Controls

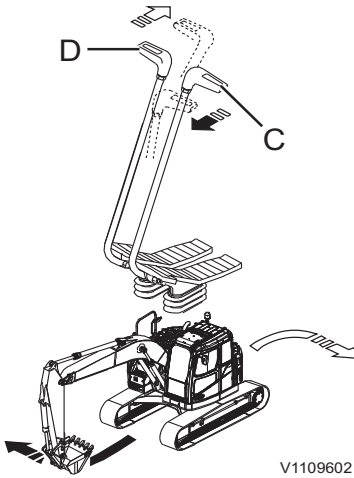

**Right turn**

- 1 When the sprockets are at the rear side of the machine  
Push the left lever (C) forward, the L/H track rotates forward and the machine travels forward as it turns to the right.  
Pull the right lever (D) backward, the R/H track rotates in reverse and the machine travels backward as it turns to the right.
- 2 When the sprocket is at the front side of the machine Operate levers (C or D) in the opposite direction as to above.

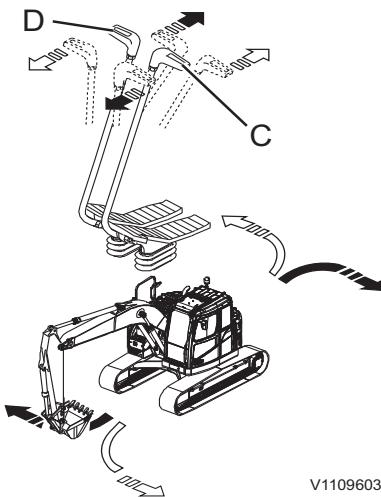

**Spin turn**

- 1 When the sprockets are at the rear side of the machine  
Pull the left lever (C) backward, the L/H track rotates in reverse; simultaneously push right lever (D) forward, the R/H track rotates forward and the machine turns on the spot quickly to the left.  
Pull the right lever (D) backward, the R/H track rotates in reverse; simultaneously push left lever (C) forward, the L/H track rotates forward and the machine turns on the spot quickly to the right.
- 2 When the sprocket is at the front side of the machine  
Operate levers (C or D) in the opposite direction as to above.

**5 Optional pedal (X1)**

- Position 1: Operating hammer  
Position 2: Operating shear or crusher  
Position 3: Lock the pedal

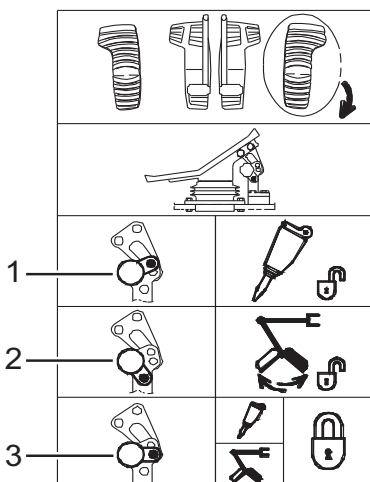

**NOTICE**

Make sure that the pedal is in locked position when it is not used in order to prevent unwanted manoeuvres.



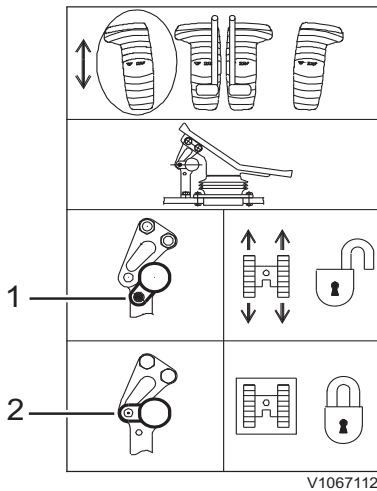

V1067112

## 6 Optional pedal (straight travel)

Position 1: Operating straight travel

Position 2: Lock the pedal

### NOTICE

Make sure that the pedal is in locked position when it is not used in order to prevent unwanted manoeuvres.

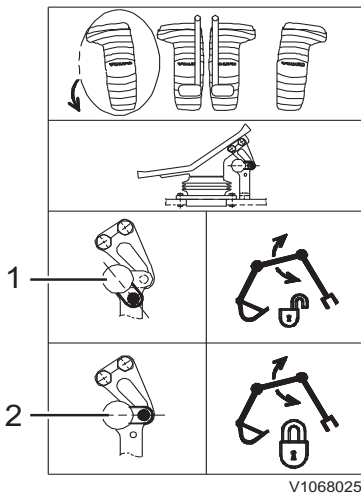

V1068025

## Optional pedal (Variable adjustable boom)

Position 1: Operating variable adjustable boom

Position 2: Lock the pedal

### NOTICE

Make sure that the pedal is in locked position when it is not used in order to prevent unwanted manoeuvres.

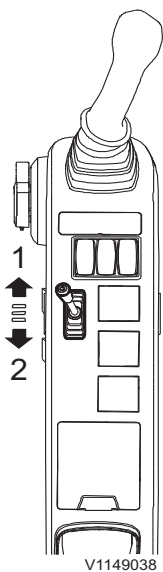

V1149038

## 7 Dozer blade lever (optional equipment)

Position 1: Dozer blade lower

Position 2: Dozer blade raise

104 Other controls  
Controls

Optional parts

Bucket/grapple valve position

Select the correct position by turning the nut with a wrench.

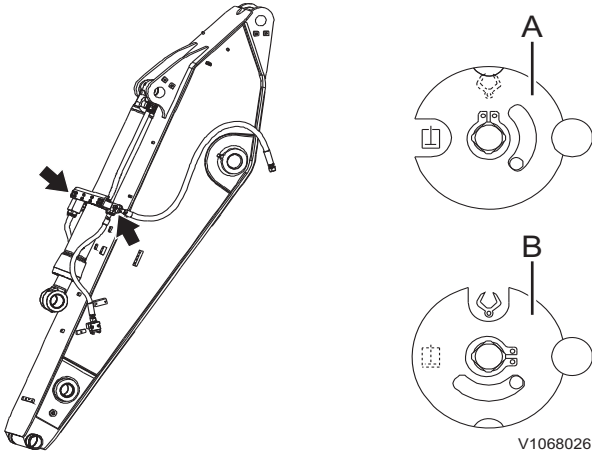

- A Bucket position
- B Grapple position

Changing control pattern of the machine (optional equipment)

- Position S: ISO/SAE type
- Position B: Backhoe loader type

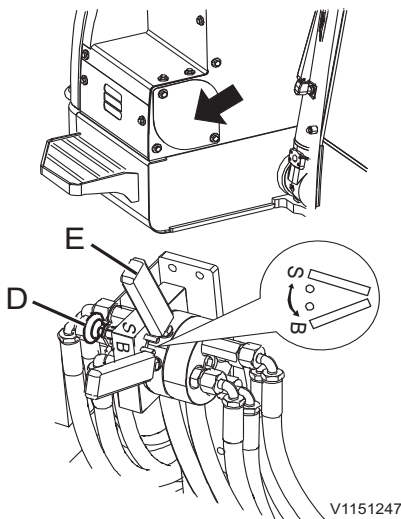

**WARNING**

Risk of serious accidents.  
Unfamiliar control patterns could cause confusion and accidents resulting in serious injury.  
**Use extreme caution when using the control levers after changing the control pattern and until you become familiar with the new pattern.**

**NOTICE**

Selected control pattern is shown on the front instrument panel. It is important to check this before using the machine.

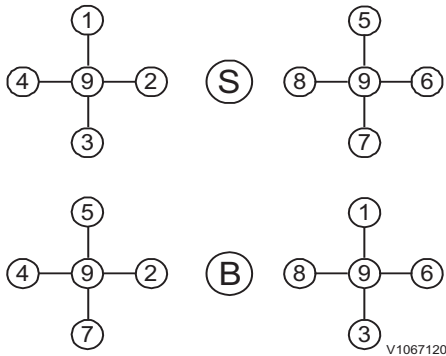

The machine control pattern can easily be changed to the ISO/SAE system or to the backhoe loader hydraulic system by changing the position of pattern change valve (if fitted).

Use the following procedure to change the position of the pattern change valve (The standard position of machine is ISO/SAE pattern type (S).

- 1 Pull the knob (D) down and move the lever (E) to S (ISO/SAE type) position or to the (B) (Backhoe loader type) position by turning.
- 2 After you set the machine control pattern, release the knob.

The patterns on the left side of the illustration show the possible configurations for the left control lever. The patterns on the right side of the illustration show the possible configurations for the right control lever.

<p>V1067121 Dipper arm out (1): Move the control lever to this position in order to move the dipper arm outwards.</p>	<p>V1067122 Swing right (2): Move the control lever to this position in order to swing the superstructure to the right.</p>	<p>V1067123 Dipper arm in (3): Move the control lever to this position in order to move the dipper arm inwards.</p>
<p>V1067124 Swing left (4): Move the control lever to this position in order to swing the superstructure to the left.</p>	<p>V1067125 Boom lower (5): Move the control lever to this position in order to lower the boom.</p>	<p>V1067126 Bucket dump (6): Move the control lever to this position in order to dump the bucket.</p>
<p>V1067127 Boom raise (7): Move the control lever to this position in order to raise the boom.</p>	<p>V1067128 Bucket close (8): Move the control lever to this position in order to close the bucket.</p>	<p>HOLD (9): When the control lever is released from any position, the control lever will return to the HOLD position. Movement of the superstructure will stop.</p>

106 Other controls  
Controls

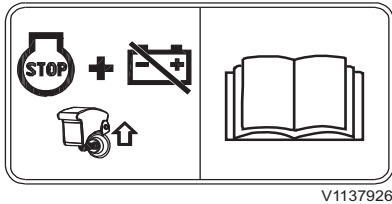
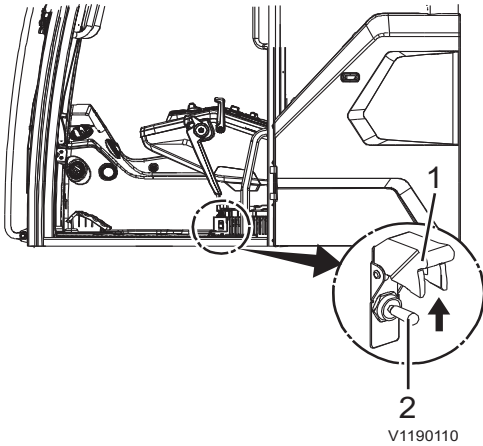

### Emergency stop switch

**NOTE!**

Emergency stop switch must be used only in case of emergency situation.

If it is abused or misused by the operator, it could cause serious failure of the engine and machine. Never use the emergency stop switch for the purpose of shutting off the normal machine.

Turn the ignition switch to the OFF position. If the engine does not stop or in emergency, perform the following procedure.

- Open cover (1) and push switch (2) upward to stop the engine.

**NOTE!**

This switch turns off the engine as well as the battery disconnect switch at the same time.

- Return the switch to the original position. The engine will be enabled to start.

**NOTE!**

Do not operate the machine again until the malfunction has been corrected.



---

## Cab

### ROPS (Roll Over Protective Structure)

The cab is designed to ensure minimum crash protection space according to ROPS standard for excavator (ISO12117-2).

The installation of any additional equipments resulting in exceeding maximum tested machine weight on a ROPS identification plate, may void ROPS certification.

Do not jump out of cab if the machine should roll over. Keep stay in seat wearing seat belt.

If any part of the cab's protective structure is affected by plastic deformation or failures, the cab shall be replaced immediately.

#### **NOTE!**

Never carry out any unauthorized alterations to the cab, for example lowering the roof height, drilling, welding on brackets for fire extinguisher, radio aerial or other equipment, without first having discussed the alteration with personnel at the Volvo Engineering Department. This department will decide whether the alteration may cause the approval to become void.

It is important that all parties concerned are aware of these regulations.



### Protection from falling or scattering materials (optional equipment)

Install the necessary protection guards according to working conditions where falling or scattering materials are capable of entering the operator's cab.

#### **FOG (Falling Object Guard) and FOPS (Falling Object Protective Structure)**

FOG and FOPS should be adopted when the machine is expected to work in an area where materials are capable of falling to the cab. Especially, in mining applications, FOG shall be adopted.

#### **Safety net**

Install safety net to minimize the possibility of breaking windshield when working with a breaker.

The above recommendations are based on standard working, install the necessary additional protection guards in accordance with job site conditions and local government regulations. Contact authorized Volvo dealer to meet local regulations.

Any damage can affect the strength of the structure. Contact a qualified service technician for repairing safety structure after damage.

Prevent persons from entering or remaining in the dangerous area.

### **NOTICE**

Check the clearance between bucket and cab or spill guard by carefully moving the bucket as close to the cab as possible. The risk of the bucket knocking against the cab is greater if attachment quick coupler is used or if the bucket is provided with lifting eyes.

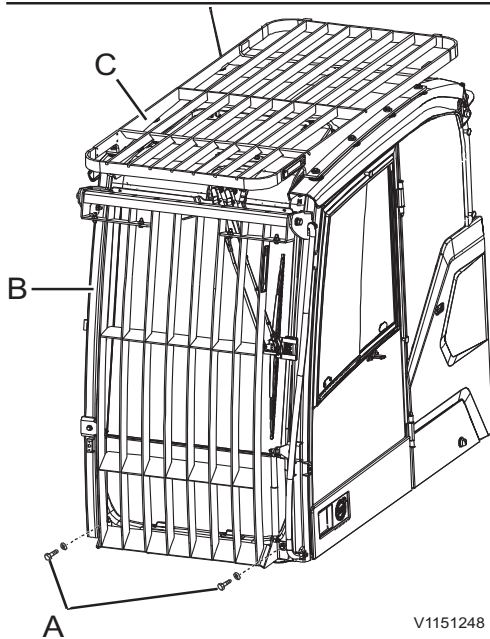

V1151248

- A Screws
- B+C FOG
- C FOPS

### Windshield with FOG, cleaning

- 1 Remove the screws (A), and then tilt the FOG.
- 2 Clean the windshield.
- 3 Fasten the screws (A) with regulated torque by pushing the FOG. ( $48 \pm 5\text{Nm}$  /  $4.89 \pm 0.5 \text{ kgf m}$  /  $35.5 \pm 3.6 \text{ lbf ft}$ )

Do not operate the machine while FOG (Falling Object Guard) is tilted. Otherwise, FOG can be damaged by the bucket.

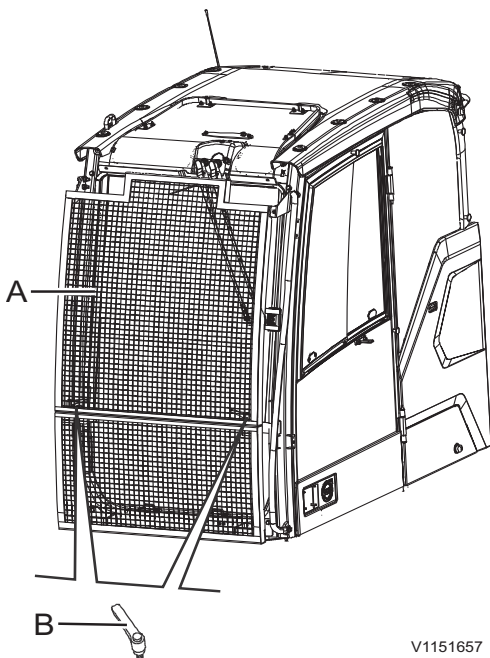

V1151657

- A Safety net
- B Handle

### Windshield with safety net, cleaning

- 1 Remove the handle (B), and then take away the net.
- 2 Clean the windshield.
- 3 Install the net.
- 4 Fasten the handle (B) by pushing the net.

110 Other controls  
Cab

---

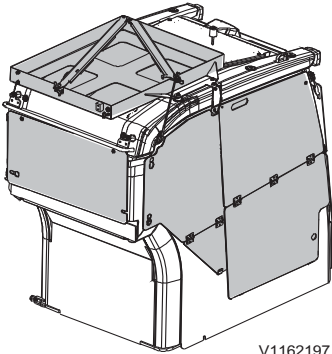
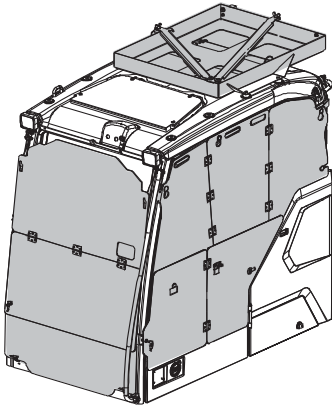

V1162197

**Anti-vandal kit (optional equipment)**

**NOTE!**

Clean mud, grease, oil, and debris from track surface, steps, walkways, and working platforms before installing the anti-vandalism covers.

Anti-vandal covers are stored on the cab.

Brackets are needed to install the covers.



## Control lockout system

### WARNING

Risk of serious injury.

Uncontrolled touch of control lever can cause unexpected movement of machine or parts. This could result in serious injury.

**Always lock the control lockout lever before starting the engine or before leaving the operator's seat.**

#### Unlocked position (A)

The control lockout lever is in **"Unlocked"** position (A) for working and travelling operations.

**When the control lockout lever is in this position the engine can not be started.**

#### Locked position (B)

The control lockout lever is used to lock out the attachment, swing and travel unit.

Place this lever on the left control console to **"Locked"** position (B) to lock out the hydraulic control levers and pedals.

**When the control lockout lever is in this position the engine can be started.**

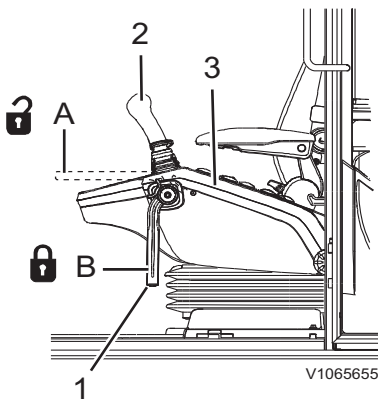

- 1 Control lockout lever
- 2 Left control lever
- 3 Left control console
- A Unlocked position
- B Locked position

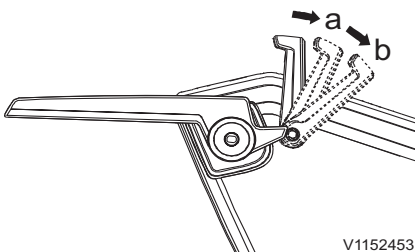

- a Control lockout lever down
- b Console up

#### Release lever for the control lockout lever and console

- 1 By pulling the release lever, the control lockout lever is put in down position.
- 2 By pulling the release lever a bit further, the console tilts up.

## Operator comfort

### Operator seat

The operator seat meets the requirements according to EN ISO7096. The operator seat is designed to provide maximum comfort and reduce vibration to the operator during normal machine operation.

**NOTE!**

Adjusting the seat should always be done when the machine is stationary.

**NOTE!**

Make sure that no objects are placed within the moving area of the operator's seat.

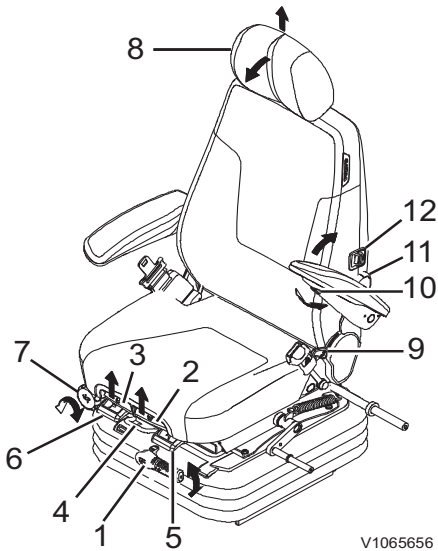

- 1 Weight adjustment
- 2 Fore & aft adjustment, seat cushion
- 3 Angle adjustment, seat cushion
- 4 Horizontal adjustment, top seat
- 5 Horizontal adjustment, top seat and consoles
- 6 X-Isolator adjustment (optional equipment)
- 7 Height adjustment, consoles
- 8 Headrest adjustment
- 9 Backrest angle adjustment
- 10 Armrest adjustment
- 11 Lumbar support adjustment
- 12 Seat heating switch (optional equipment)

**! WARNING**

Risk of serious injury.

Uncontrolled touch of control lever can cause unexpected movement of machine or parts. This could result in serious injury.

**Always lock the control lockout lever before starting the engine or before leaving the operator's seat.**

**NOTICE**

Installation and maintenance of the operator seat may only be carried out by authorised and competent personnel.

**NOTICE**

To obtain maximum comfort and eliminate the risk of accidents, you must make sure that all seat adjustments have been carried out correctly before starting the machine.

**NOTE!**

The seat is intended for use by one seated occupant only.

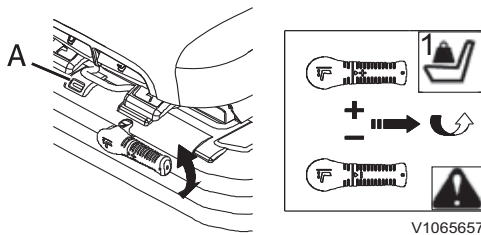

A Ride indicator

## Mechanical suspension seat

### 1 Weight adjustment

Adjust the seat to the drivers weight by turning the weight adjusting handle. The set weight should be within the green zone of the ride indicator.

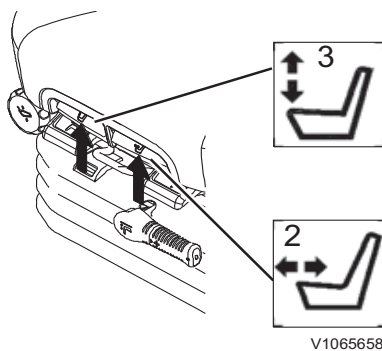

### 2 Fore & aft adjustment, seat cushion

Lift the lever (2) and adjust the seat cushion fore & aft.

### 3 Angle adjustment, seat cushion

Lift the lever (3) and adjust the angle of the seat cushion. It may be necessary to reduce occupant pressure on the seat cushion when performing this adjustment.

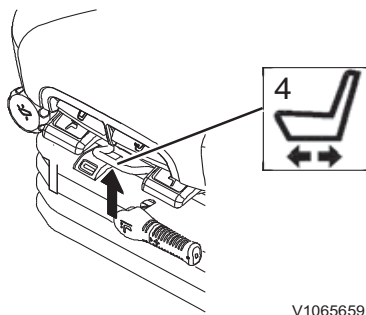

### 4 Horizontal adjustment, top seat

It is possible to move the seat forwards and backwards relative to the control consoles. Lift the handle (4) and move the seat so that the consoles are in the desired position relative to the seat. The locking lever must latch in the desired position. It should not be possible to move the seat into another position when it is locked.

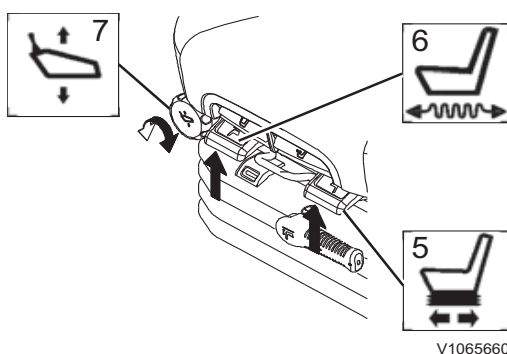

### 5 Horizontal adjustment, top seat and consoles

The seat and the consoles can be adjusted forwards and backwards. Lift the lever (5) and move the seat and consoles to the desired position. The locking lever must latch in the desired position. It should not be possible to move the seat into another position when it is locked.

### 6 X-Isolator adjustment (optional equipment)

It is possible to adjust the seat to provide fore and aft isolation. It can be used to reduce fore and aft shocks of the seat. Lift the lever (6) to activate the isolator, push down to deactivate this adjustment.

### 7 Height adjustment, consoles

Rotate the handle (7) and adjust the height of the control consoles.

114 Other controls  
Operator comfort

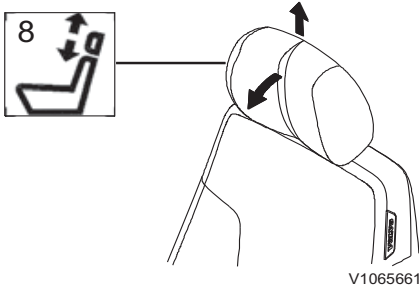

**8 Headrest adjustment**

The headrest can be adjusted for height by pulling up or down. End stops limit the movement. It can be also adjusted for angle by pushing forwards or backwards. End stops limit the movement.

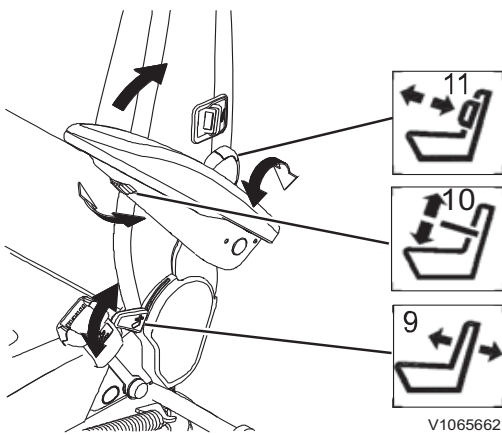

**9 Backrest angle adjustment**

Pulling up the control handle (9) releases the backrest latch. The back of the seat can then be reclined backwards or forwards to the desired position. Releasing the handle allows the backrest to move to a latching position.

The locking lever must latch in the desired position. It should not be possible to move the backrest into another position when it is locked.

**10 Armrest adjustment**

Inclination of the armrest can be changed by turning the adjustment knob (10) mounted on the underside of the armrest. The armrests can be manually tipped up if required.

**11 Lumbar support adjustment**

Rotate the knob (11) in the direction of the arrow to increase the amount of lumbar support (five positions). Further rotation in the same direction causes the lumbar support to return to minimum.

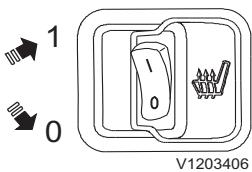

**12 Seat heating switch (optional equipment)**

This is used to warm up the operator seat. The seat heating will activate when this switch is in position (1) and the temperature is under 26 °C (79 °F). The seat heating stops when the temperature is up to 36 °C ( 97 °F), and will activate again when the temperature turns down under 26 °C (79 °F) again.

- 0 Seat heating, OFF
- 1 Seat heating, ON

## NOTICE

To reduce the risk of fire the seat heating must be switched off before you leave the seat.

### Air suspension seat (optional equipment)

The operator seat is also available with air suspension for even better comfort. The adjusting possibilities are the same as for a mechanical suspension seat except adjustment of air suspension.

To adjust air suspension of the seat,

- 1 Turn the ignition switch "ON" or start engine.
- 2 Lift operator's weight off the seat.
- 3 Lift and hold the lever (A) until air bag is completely inflated.
- 4 Sit and push down the lever (A) to deflate.
- 5 Stop deflating when seat starts lowering. The set weight should be within the green zone of the ride indicator.

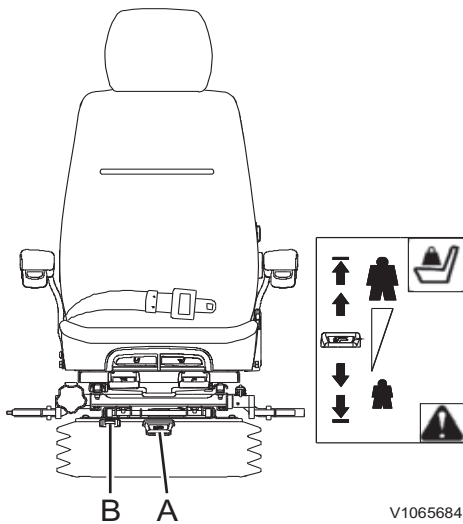

V1065684

- A Adjusting lever  
B Ride indicator

### NOTE!

After adjusting the suspension with operator's weight, the suspension height should be in the position within suspension stroke.

## Seat belt

### WARNING

Risk of serious injury!  
Unexpected machine movement can cause the operator to be ejected from the machine, causing serious injuries.

**Operate the machine only while seated in the operator seat with the seat belt fastened.**

The seat belt is critical to operator safety and must be worn at all times during machine operation to prevent the operator from being ejected from the cab or the operator platform if the machine rolls over or is involved in an accident. A fastened seat belt also helps the operator to maintain control of the machine if it moves suddenly or in an unexpected way. Failure to wear a seat belt during machine operation could result in serious injury or death. The seat belt is intended for one adult only. Keep the belt rolled up when not in use.

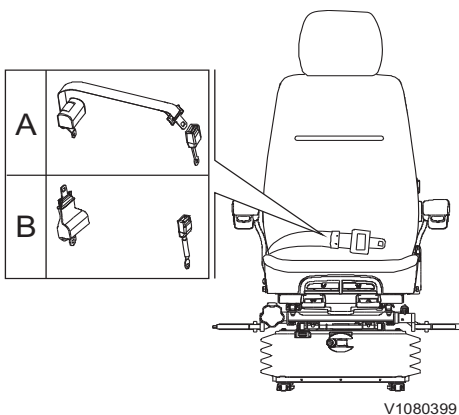

- A Retractable type (2 inches)
- B Retractable type (3 inches)

### WARNING

Risk of serious injury or death.  
A damaged seat belt could cause serious injury or death.

**Check the seat belt and associated parts before start of machine operation.**

Check the seat belt and associated parts daily. Ensure mounting hardware is tight. Replace the entire seat belt immediately if there is any wear, the webbing is worn, cut, has loose stitching, the belt is deformed or the seat belt retractor does not work. Replace the seat belt if the machine has been involved in an accident where the belt has been subjected to high strain or loading. Inspect mounting hardware. Changes to the belt or its mountings must never be made. Only clean with warm water, do not use soap or detergent. Let the belt dry while it is fully pulled out before rolling it in.

Volvo Construction Equipment recommends replacing seat belt assemblies every 3 years regardless of appearance.

## Climate control system

### HVAC system (Heating, Ventilation, Air Conditioning)

The machine can be equipped with different kinds of systems, for example, with air conditioning unit or heater with air conditioning unit. Before operating the system, check the detailed information for your machine.

#### 1) HVAC control button

- Press the button briefly to turn on/off the HVAC system. All settings remain if the system is turned off.
- Press and hold in the button to setup the HVAC system.

#### NOTE!

Even if the HVAC system is turned off, when CCM (Climate Control Module) gets an auxiliary heater signal, the CCM turns on the cooling fan setting 1st step in manual mode.

#### 2) Arrow up button

This button is used to scroll between items and adjust each segment on the screen.

#### 3) Defroster select button

Press the button to activate the defroster. Fresh air mode is selected automatically. In auto mode, if this button is pressed, mode shall change to manual mode.

#### NOTE!

After 20 minutes, this setting is automatically returned to the previous mode.

#### 4) Arrow right button

This button is used to scroll between items and adjust each segment on the screen. Press this button in order to increase the temperature.

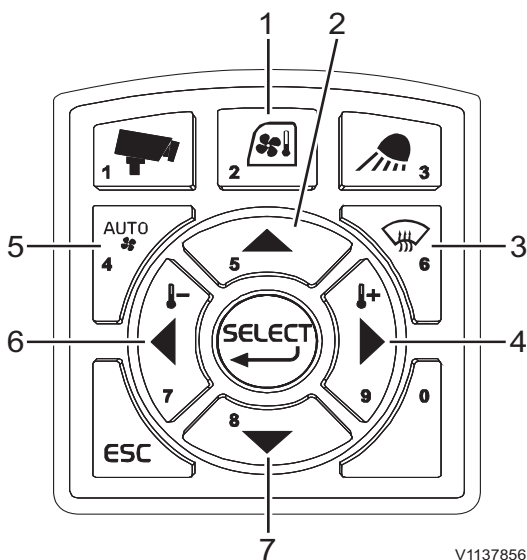

118 Other controls  
Operator comfort

5) HVAC auto-mode select button

This button is used to select the auto-mode for temperature setting. Required temperature can be changed on the setup menu.

6) Arrow left button

This button is used to scroll between items and adjust each segment on the screen. Press this button in order to decrease the temperature.

7) Arrow down button

This button is used to scroll between items and adjust each segment on the screen.

HVAC setup

Press and hold in the HVAC control button (1) to setup the HVAC system.

A) Climate mode selection

This is for selecting climate mode. (auto, manual, or defrost)

Mode selection and fan speed in manual mode are controlled with the arrow left or arrow right button.

B) Temperature control

■ **Auto mode:** Temperature can be adjusted with the arrow left or arrow right button.

Default setting value is 22°C (71.6°F) and the setting range is 16°C ~ 32°C (60.8°F ~ 89.6°F). If the temperature sensor in cab fails, auto mode shall turn off.

See page 44 for details on how to change the temperature unit from degrees Centigrade to Fahrenheit.

■ **Manual mode:** Temperature is divided into 8 steps and it can be adjusted with the arrow left or arrow right button. According to the selected step, the temperature will be changed automatically.

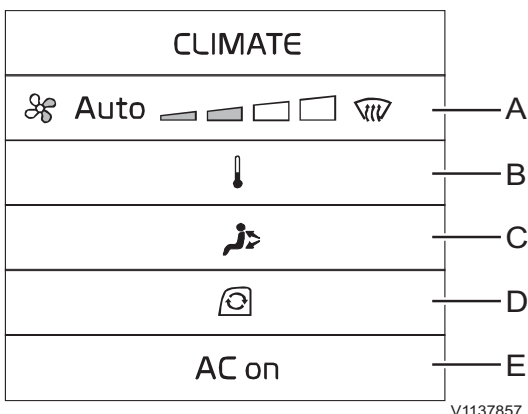



**C) Air flow direction**

This is for selecting the direction of the air flow.

**D) Air flow circulation**

This is for selecting the circulation of the air flow.  
(recycle the air inside the cab or draw fresh air from the outside into the cab)

When defrost mode is activated, fresh air mode is selected automatically.

**E) Air conditioner on/off**

This is for turning the air conditioner on/off.

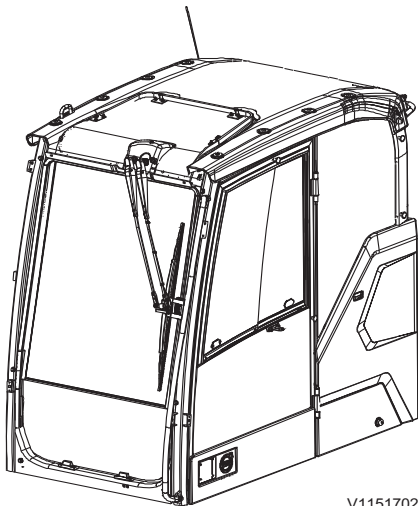

V1151702

## Windows

### Front windshield, opening

#### **NOTICE**

Move the control lockout lever down to its lower position before you open or close the windscreen.

- 1 Lower the attachment to the ground and stop the engine.
- 2 Push both buttons (E) in order to unlatch the windshield from the locked position (G) while holding both grips (F), and then move the windshield upward.

#### **NOTE!**

Stop lifting as soon as the windshield is unlatched.

- 3 Hold both grips (F) only and pull the windshield upward and rearward, and then fix it in the locked position.

#### **NOTE!**

If the windscreen is cracked, it must be replaced immediately. Contact a qualified service technician for replacing.

### Front windshield, closing

- 1 Lower the attachment to the ground and stop the engine.
- 2 Push the both buttons (E) with holding both grips (F) to move the windshield out of the lock position.
- 3 Grip handle (F) only and pull the windshield downward slowly.
- 4 Fix the windshield securely and tighten in the locked position (G).

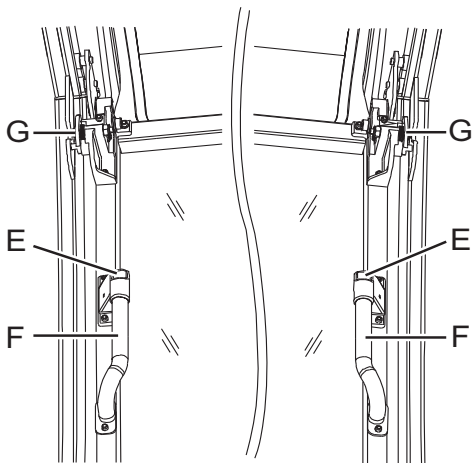

V1065687

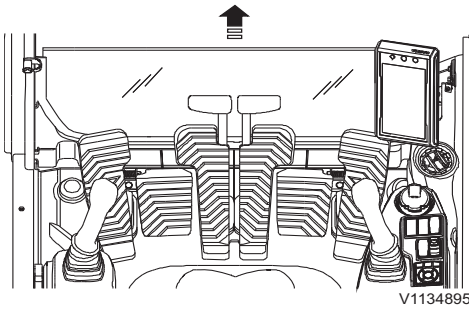

### Lower window, removing

- 1 Open the front windshield.
- 2 Grip the upper part of lower windshield with both hands and pull it upward.
- 3 Put the removed windshield in safety place (C).

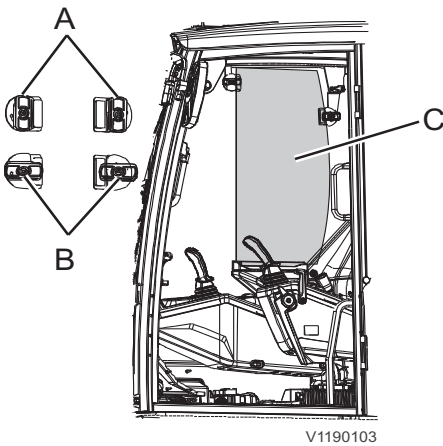

- A Unlock position  
B Lock position

### Door

Door lock (A) is used to keep the cab door secure in the open position.

- 1 Push the door against outside of the cab.
- 2 Ensure it is securely fixed to the lock (A)

Press the lever (B) inside the cab to release the door.

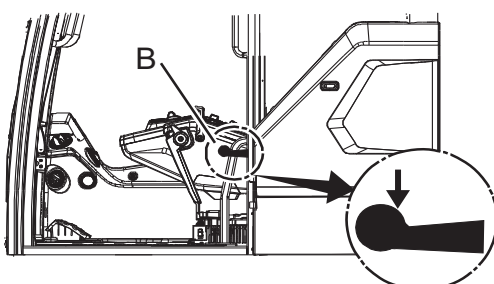
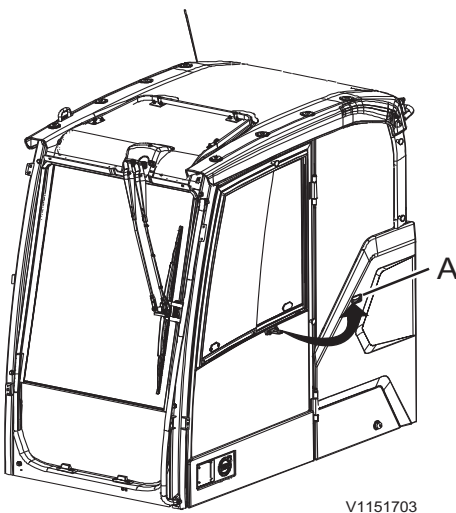

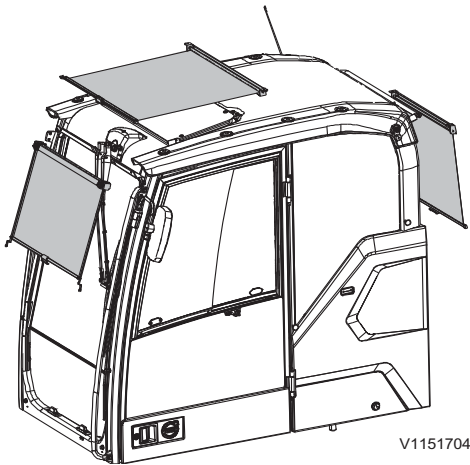

- 1 Front sun shade
- 2 Roof sun shade
- 3 Rear sun shade

## Sun shade

Use the front, roof and rear sun shades to protect from the sun light coming in through windows.

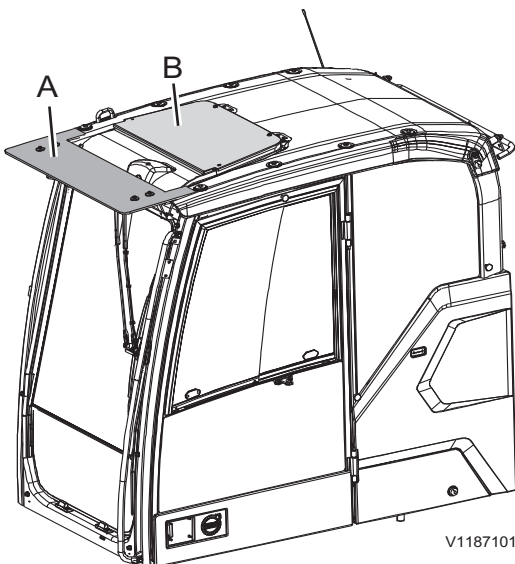

- A Rain shield
- B Sun shield

## Rain shield

A rain shield prevents rain from falling on the operator's feet when windshield is open.

### **NOTICE**

With certain attachment combinations there is a risk that the attachment may strike the cab. Avoid damage by being careful when working close to the machine.

## Sun shield

### (optional equipment)

A sun shield on the roof reduces incoming light and heat radiation further.

When installing the sun shield roof, consider other optional equipments, for example, rain shield, anti-vandal kit and so on.

## Hour meter

The hour meter shows the total number of hours the engine has operated. It records the hour only when the engine is running.

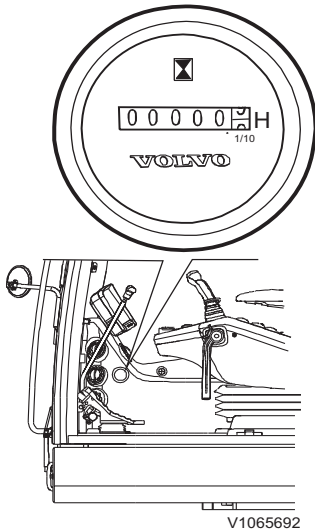

## Roof

### Roof hatch, open

- 1 Grip the handle (1) and turn it to open direction (2).
- 2 Open the roof (3).

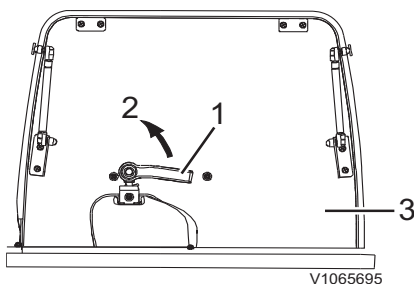

- 1 Handle
- 2 Open direction
- 3 Roof hatch

### **NOTICE**

The roof hatch must be securely locked when transporting.

### **NOTE!**

Cab with fixed roof hatch is provided as an optional equipment. In this case, there is no handle and gas spring.

## Storage compartment

A storage compartment is located at the rear side of operator seat.

### **NOTE!**

Do not store tools in the storage compartment. This could damage the compartment.

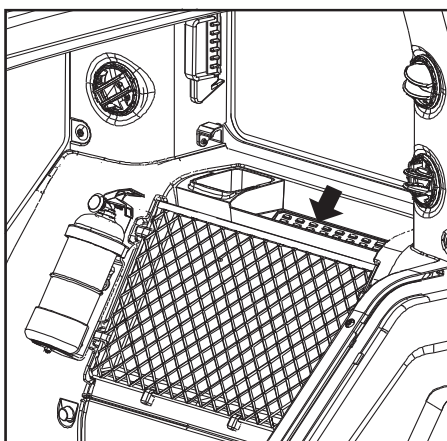

124 Other controls  
Operator comfort

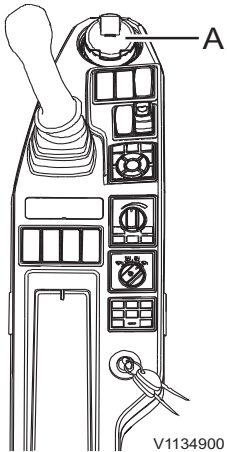

**Ashtray (optional equipment)**

Pull the top edge of the ashtray (A) in order to open it.  
Pull the ashtray upward out of the console when cleaning it.

**NOTE!**

Make sure that you close the ashtray after use in order to prevent any possibility of fire.

**NOTE!**

The ashtray can be put into the cup and drink holder.

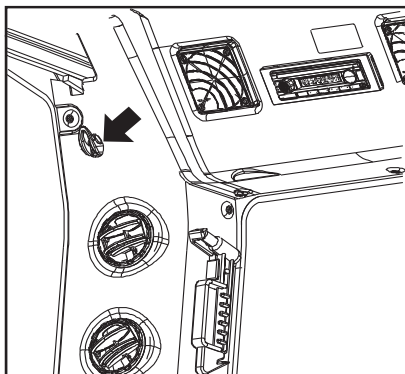

**Coat hook**

The coat hook is inside the cab.

**NOTE!**

Do not hook any item that may obstruct the view of the operator.

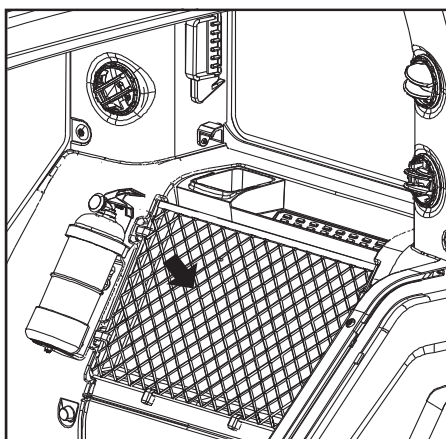

**Operator's manual, storage**

Operator's manual storage is located at the backside of seat. Keep the manual in the storage so that it is always at hand.

## Fire extinguisher, location

(optional equipment)

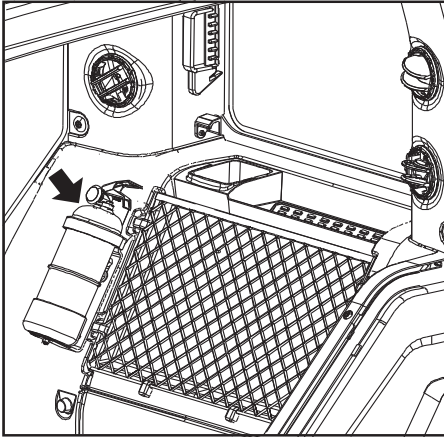

V1151749

## Emergency exit

The cab has two emergency exits, the door and the rear windshield.

Regardless of the rear windshield types, break the glass with the hammer attached on the rear side in a cab.

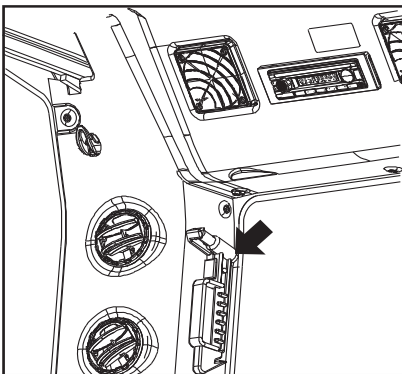

V1151750

Hammer

### **NOTICE**

The hammer must not be removed from its position or be used at other occasions than in an emergency situation. If the hammer should be lost, it must be replaced immediately.

### **NOTICE**

There is a knife on the hammer for the emergency exit. Cut off the seat belt with the knife, if the buckle cannot be undone.



## Audio system

### 1 Radio setting method by region

- Europe: Press the FM/AM button, and then press preset 6 for 2 seconds.

#### NOTE!

Setting is completed when "EU" message is shown.

- North America: Press the FM/AM button, and then press preset 4 for 2 seconds.

#### NOTE!

Setting is completed when "NA" message is shown.

- Others: Press the FM/AM button, and then press preset 5 for 2 seconds.

#### NOTE!

Setting is completed when "INT" message is shown.

### 2 Tuning ranges

	Band	Frequency
Europe	FM	87.50 ~ 108.00 MHz
	AM (MW)	531 ~ 1629 KHz
	LW	144 ~ 288 KHz
North America	FM	87.50 ~ 108.00 MHz
	AM	530 ~ 1710 KHz
Others	FM	87.50 ~ 108.00 MHz
	AM	531 ~ 1629 KHz



Radio and USB-MP3 Player (optional equipment)

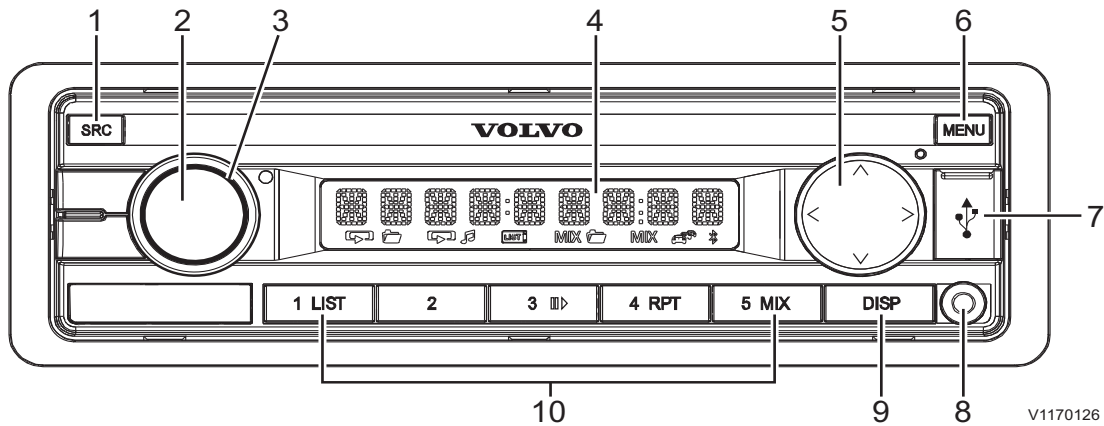

1	SCR button	6	MENU button
2	On/Off button	7	USB socket
3	Volume control	8	AUX
4	Display	9	DISP button
5	Select button	10	Preset button 1-5

1 **SRC button**

Select memory bank or audio source.

- Short press: Switch among radio<sup>1</sup>, USB, AUX source.

- Long press: Activate Travel-Store function in radio mode. (Setting kept in FMT or AMT<sup>2</sup> memory bank)

**NOTE!**

Radio<sup>1</sup> is switched on as FM1, FM2, FMT, MW, LW, AM or AMT, MW, LW, AM or AMT are only available in respective tuner regions.

**NOTE!**

AMT<sup>2</sup> in tuner regions INTERNAL, N-AMERICA and JAPAN.

2 **On/Off button**

- Short press: Switch on audio system.

- Long press: Switch off audio system.

- In operation: Mute audio system.

3 **Volume control**

Adjust the volume

- In the menu: Change settings.

- Fast-Browse mode: Select folder and track.



128 Other controls  
Operator comfort

---

4 **Display**

5 **Λ / V button**

- In the menu: Select menu item.
- Radio mode: Start seek tuning.
- MP3/WMA/iPod mode: Change to next/previous folder.

**< / > button**

- In the menu: Change menu level.
- Radio mode: Adjust the stations.
- Other operating modes: Track selection.

6 **MENU button**

- Short press: Close menu.
- Long press: Start scan function.

7 **USB socket**

8 **AUX**

9 **DISP button**

Switch display.

10 **Preset button 1–5**

- Short press: Call up the stored station in radio mode.
- Long press: Store station on the current memory bank in radio mode.

■ **Area**

This audio system is designed for operation in different regions with different frequency ranges and station technologies. The factory default of the reception area is "EUROPE". In addition, the reception areas are "N-AMERICA", "INTERNAL" and "JAPAN" are available.

If you operate the audio system outside of internal, you may first have to set a suitable reception area in the menu:

- 1 Briefly press the MENU button to open the user menu.
- 2 Press the > button until the TUNER menu item is selected.
- 3 Press the Λ / V button until the "AREA" menu item is selected.
- 4 Press the > button to set the reception area.
- 5 Press the > button to confirm the selected area.



■ **iPod mode**

This audio system can play audio from iPod/iPhone device via USB socket.

- 1 Insert the iPod via USB extension cable in USB socket
- 2 Press the SRC button repeatedly until the USB source is displayed.

A connected iPod is selected as audio source as soon as the iPod has been recognized.

■ **Browse mode**

In browse mode, you can directly search for and select a certain track on the MP3/WMA data carrier without interrupting the current play back. In iPod mode, you can select and play a track using the categories "Now Playing", "All Tracks", "Playlist", "Genre", "Artist", "Album", "Composer", "Audiobook" and "Podcast".

■ **Selecting tracks in Browse mode**

- During iPod playback, press the LIST button to enter or exit the browse mode. It will show current playing tracks stored in the iPod, press button to view all category.
- Press the  $\wedge$  /  $\vee$  button once or several times to select a different folder.
- Press the > button to display the tracks of the selected folder. The first track of the folder is shown on the display.

**NOTE!**

Press the < button returns you to the folder list.

- Press the  $\wedge$  /  $\vee$  button once or several times to select a different track.
- Press the > button to play the track. The playback starts. You are exiting the browse mode.

**NOTE!**

Fast searching is not available in Browse mode.

130 Other controls  
Operator comfort

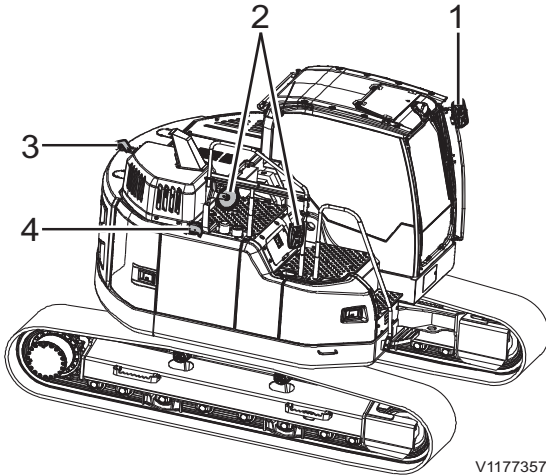

V1177357

Mirrors and cameras (if installed)

### Vision system

The machine has a lot of equipment for the operator to minimize visibility hazards. Using this equipment, the operator must always ensure good visibility of the surroundings when operating the machine.

- 1 Left mirror
- 2 Right mirrors

**NOTE!**

Right mirrors are used as aids for better visibility.

- 3 Rear-view camera
- 4 Side-view camera

**NOTE!**

Any modifications done to the machine that affect the operator's visibility must be verified by a Volvo dealer.

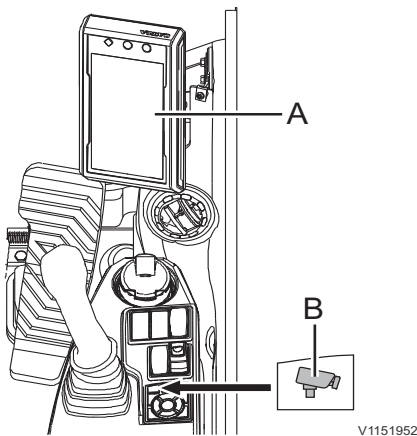

V1151952

### Camera system (if installed)

The camera screen in the IC (Instrument Cluster) (A) is shown if any condition of below is met:

- by pressing the camera button (B) on the keypad or
- when operating any control lever (joystick) / pedal or
- without keypad signal during 10 seconds.

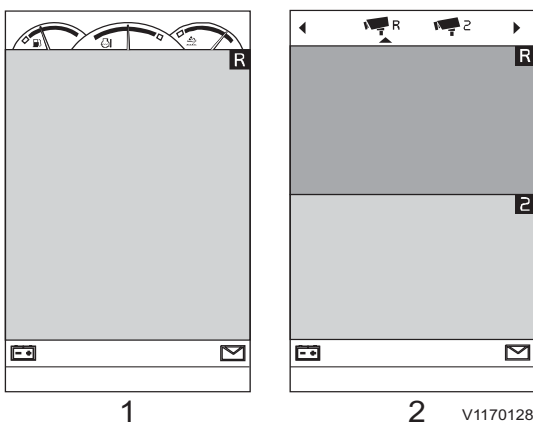

V1170128

- 1 Camera view with gauges
- 2 Camera view with configuration bar

- **A short press on the camera button shows the camera view with gauges (1):**

This camera view (1) shows the camera screen (depending on the selected configuration) with the fuel level, engine coolant temperature, and AdBlue®/DEF level.

- **A long press on the camera button shows the camera view with configuration bar (2):**

This camera view (2) shows the camera screen with the camera configuration bar at the top. The camera configuration bar is used to show or hide camera views on the IC (Instrument Cluster). Press the camera button (B) on the keypad to rotate the camera views clockwise.

Select one of the camera icons and press SELECT on the keypad to show or hide this camera view.

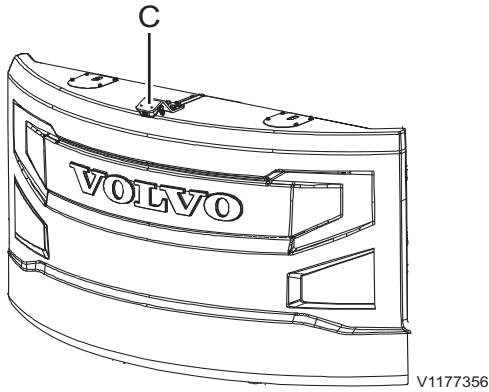

### Rear-view camera (if installed)

The rear-view camera (C) is installed on top of the counterweight.

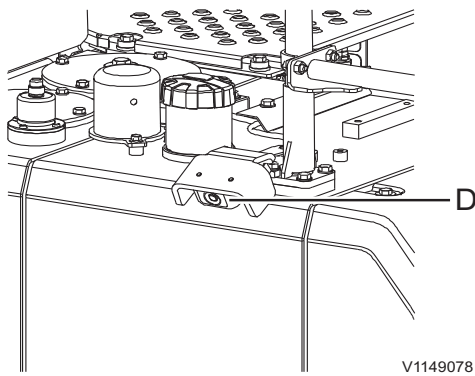

### Side-view camera (if installed)

The side-view camera (D) is installed on the guardrail on the machine's right side.

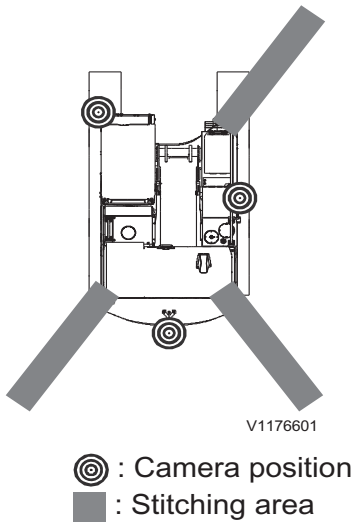

## Volvo Smart View (Optional equipment)

Volvo Smart View (VSV) shows a real-time, overhead view of the machine during operation. This system helps your visibility and to see all angles (360°).

### NOTE!

Volvo Smart View is a synthetic view which is intended to be used as a convenient vision-assist system. Always check visually around the machine, especially the stitching areas, to be sure.

### NOTE!

A Volvo dealer may have to perform a VSV-calibration if any installed camera position is changed.

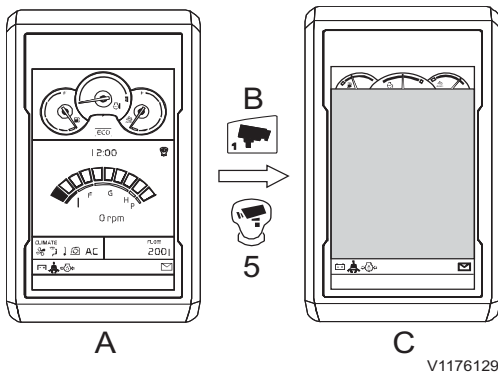

- A Main screen of IC
- B Camera button on keypad
  - **Short press:** VSV-screen
  - **Long press:** VSV-configuration
- C Volvo Smart View screen

If the camera button (B) or joystick shortkey (5) is pressed briefly: single view is shown according to the view sequence below. Press the button (B) or (5) until the desired view is shown.

**Split-view<sup>(1)</sup> → Top view 1 (long range view) → Top view 2 (short range view) → Side mirror view → Rear view → Right side view → Off**

- **Top view 1 (long range view):** synthetically created allround view generated from the installed cameras. This view could be used for checking objects/people at relatively long distance around the machine.
- **Top view 2 (short range view):** synthetically created allround view generated from the installed cameras. This view could be used for checking objects/people near the machine
- **Side mirror view:** Left and right mirror view are also displayed on **Top view 1**. This view could be used for checking objects/people to the side of the machine (especially stitching areas).
- **Rear view:** this view is only transmitted by the rear view camera.
- **Right side view:** this view is only transmitted by the right side view camera.
- **Off:** turn OFF the VSV-system. Main screen is displayed on IC.

**NOTE!**

Always turn on the camera view(s) when operating the machine. For more information, see page 44 and 130.

1. this view can be displayed when presetting is done

134 Other controls  
Operator comfort

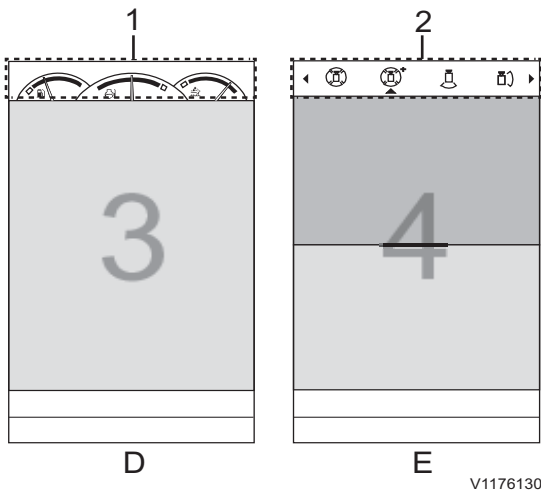

D VSV-screen  
E VSV-configuration screen

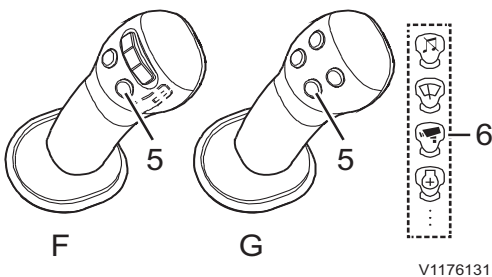

Shortcut (multifunctions) button (5) on left lever

- F Proportional switch type
- G Four-button type

If the camera button (B) is pressed for more than 1 second:

configuration bar (2) is shown. Select two types of views with 4 icons.

Split-view setting

Top view 2 (short range view) ↔ Side mirror view ↔

Rear view ↔ Right side view

NOTE!

The displayed gauges (1) can be different according to machine type.

NOTE!

VSV-system supports single view (3) among five views or split-views (4) within **Top view 2**, **Mirror view**, **Rear view** and **Right side view**.

VSV can be turned ON using the shortcut button (5) if this button is assigned to the camera function (6). For more information about joystick shortcut, see page 44. (**MENU** → **Setup** → **Joystick shortcut** → **Camera**)

If necessary, an additional camera may be installed according to user need. In this case, the VSV-system can be turned ON using camera button (B) on the keypad. An additional camera view is only shown using joystick shortcut button (5). (**MENU** → **Setup** → **Joystick shortcut** → **Extension camera**)

NOTE!

According to machine options, an extension camera can not be installed. Contact an authorized Volvo dealer to install an extension camera and for additional information.



## Auxiliary heater

### (Optional equipment)

Check which of the two auxiliary heater control unit versions is installed in your machine.

The auxiliary heater is used for heating the engine coolant by a fuel combustion unit while the engine is stopped. It consists of the fuel tank, fuel pump, water pump, the timer and the heating unit. The auxiliary heater facilitates the engine start and heating the cab in severe cold weather.

The heated coolant is circulated through the engine block → water pump → auxiliary heater → heater core → engine block.

The auxiliary heater timer can be used to make the necessary settings for operation of the heater.

### Button functions

If the display is not lit the timer must be activated. SHORTPRESS on one of the four buttons, the start display appears in the display, then continue with the operation or setting.

All functions can be set and, if necessary, changed with only 4 buttons.

#### 1 Power on / confirm button

##### ■ SHORTPRESS button

- if the display shows OFF → Timer On, the start display appears.
- A selected function is confirmed.
- Inputs are confirmed.

##### ■ LONGPRESS button : The button must be pressed for longer than 2 seconds.

- The heater is switched on immediately if On or OFF appears in the display.

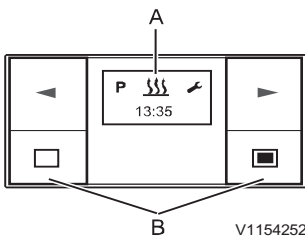

A Display window  
B Buttons

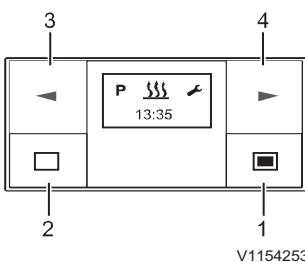

1 Power on / confirm button  
2 Power off / cancel / exit setting button  
3 Backward button  
4 Forward button

## 136 Other controls Operator comfort

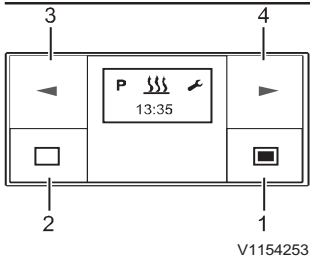

- 1 Power on / confirm button
- 2 Power off / cancel / exit setting button
- 3 Backward button
- 4 Forward button

### 2 Power off / cancel / exit setting button

#### ■ SHORTPRESS button

- The displayed, activated function is ended, other activated functions are retained.
- With each SHORTPRESS the display changes to a next-higher level up to Timer OFF.
- The start display appears and no function is active: → Timer OFF.
- Timer is in submenu → the setting is exited, already set values are not saved.
- If the display shows OFF → Timer On, the start display appears.

#### ■ LONGPRESS button : The button must be pressed for longer than 2 seconds.

- All functions are ended.
- If the display shows OFF → Timer On, the start display appears.

### 3 Backward button

- Timer is in the Main menu and the start display appears → in the Menu bar the next, left-hand symbol appears in the middle and flashing.
- Timer is in the submenu → the displayed value is changed (smaller), or the next selection is displayed.
- If the display shows OFF → Timer On, the start display appears.

### 4 Forward button

- Timer is in the Main menu and the start display appears → in the Menu bar the next, right-hand symbol appears in the middle and flashing.
- Timer is in the submenu → the displayed value is changed (larger), or the next selection is displayed.
- If the display shows OFF → Timer On, the start display appears.

## Operation and setting/adjustment

### Main menu

#### Menu bar

The following menu items can be selected.

Symbol	Function
	Heating ON / OFF
	Settings
<b>P</b>	Program / Preselection

#### Status area

If no menu item is activated, the current time is displayed in the status area.

If a menu item is activated (heating, settings or program / preselection), different information is displayed in the status area.

### Submenu

In the submenu, the symbol of the selected menu item appears in the middle of the display. The corresponding set value is displayed flashing in the entry area and can be set using the Backward button (3) or Forward button (4) and confirmed with the Confirm button (1).

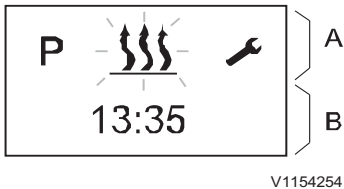

V1154254

#### Main menu

A Menu bar

B Status area

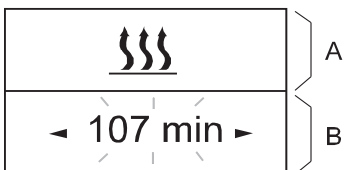

V1154255

#### Submenu

A Menu bar : activated function

B Input area



V1154256

### Start display after switching ON

if no menu item is activated, the start display appears with a flashing heater symbol in the Menu bar, with the current time in the status area.

### Other possible actions are:

- Heating immediately with LONGPRESS button (1).
- Heating on with SHORTPRESS button (1), in addition confirm and set the operating time.
- Select a new menu item.

138 Other controls  
Operator comfort

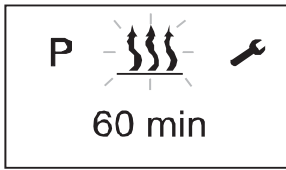

V1154257



V1154258

1 Heating ON / OFF

■ Heating immediately with LONGPRESS (without settings)

- 1 Press the LONGPRESS button (1) for longer than 2 seconds.
- 2 Screen shows remaining operating time.
- 3 If LONGPRESS is pressed during heating mode, the display switches to the heating submenu set and set operating time. During heating mode it is possible to switch to another menu item.

■ Heating on with SHORTPRESS and with settings

- 1 Press the SHORTPRESS button (1) for less than 2 seconds.

**NOTE!**

The following settings and confirmations (operating time) are always required.

- 2 If necessary, use the BACKWARD or FORWARD button to set the operating time. Press the confirm button (1) to confirm the operating time.

■ Heating OFF

- Press the button (2) for longer than 2 seconds. → all active functions are ended.
- Press the button (2) for less than 2 seconds. → heater OFF.

After the heating off the start display appears. if the vehicle lighting is off the display lighting goes out after 10 seconds.

**The following actions are possible during the heating off display:**

- Use the forward or backward button to select a menu item. Press the SHORTPRESS button (2), the start display appears.
- Press the SHORTPRESS button (1), the heating submenu is displayed.

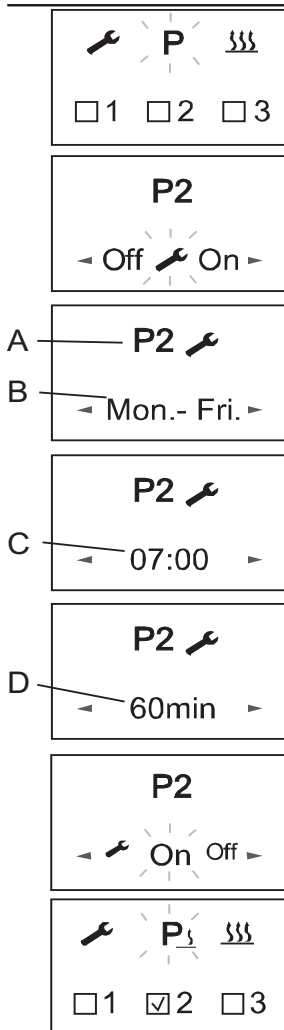

V1154261

- A Preset unit
- B Preset day
- C Departure time
- D Operating time

## 2 General information on programming the preset time

Timer can be used to program 3 preset times. The 3 preset times can either all take place on one weekday or can be distributed between different weekdays. 3 weekday ranges are available to choose from, these can each be started daily with a preset time.

### ■ Weekday ranges:

Day: Once

Sat-Sun: 2x Heating

Mon-Fri: 5x Heating

Mon-Sun: 7x Heating

- If the system is activated with programmed weekday range, all weekdays are worked through consecutively; after that renewed programming is required.
- If the timer with a programmed weekday range Mon – Fri is activated on Wednesday, the heater heats on Thursday and Friday, the heater is not operated on Saturday and Sunday. From Monday to Wednesday of the following week the operation is continued with the set defaults (5x heating). After a weekday range has been worked through renewed programming is required.

### ■ Departure time operating mode (factory setting)

Under the following conditions the preselected heating mode is not started on the current day.

- The current day and the preselected day are identical.
- The current time lies within the time period, departure time minus operating time.

140 Other controls  
Operator comfort

**Example:**

Current day / preselected day: Mon  
 Current time: 06:45  
 Departure time: 07:00  
 Operating time: 60 minutes  
 Duration: 06:00 to 07:00  
 The current time lies within the time period,  
 the heater is not switched on.  
 The program will be run during the next  
 week.

■ **Program preset times**

- 1 Use the backward or forward button to select the Program symbol in the menu bar.
- 2 Confirm the Program menu by pressing the confirm button (1).

If the Program symbol is marked with **P**<sub>3</sub>, a or several program memories is/are already activated.

Activated program memories are marked in the display with a .

3 Settings

This function is for setting current day and time.

- 1 Use the backward or forward button to select the setting symbol in the menu bar.
- 2 Confirm the setting menu by pressing the confirm button.
- 3 Use the backward or forward button to select the submenu which want to change the setting.
- 4 Press the confirm button to confirm the setting value.

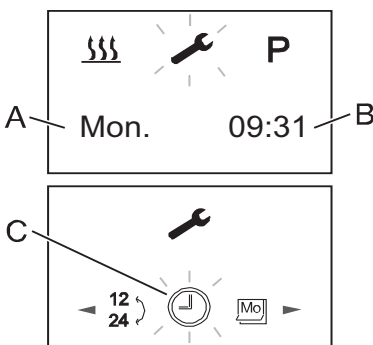



V1154262

- A Current day
- B Current time
- C Settings submenu bar

### Error messages

In the event of a fault the following displays are possible:

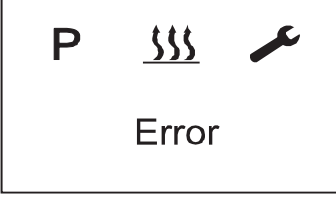
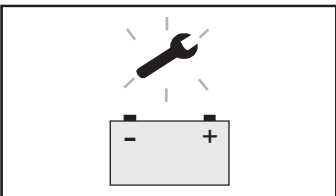
Display	Description	Remedy
 <p>V1154443</p>	<ul style="list-style-type: none"> <li>- Automatic detection is active.</li> <li>- The auxiliary heater timer has been disconnected from the power supply and then reconnected.</li> </ul>	<p>Wait until the automatic detection has finished, then set the time and weekday.</p>
 <p>V1154444</p>	<ul style="list-style-type: none"> <li>- No communication.</li> </ul>	<p>Check and if necessary renew the heater fuse. Contact a workshop authorized by Volvo.</p>
 <p>V1154445</p>	<ul style="list-style-type: none"> <li>- Heater fault.</li> </ul>	<p>Contact a workshop authorized by Volvo.</p>
 <p>V1154447</p>	<ul style="list-style-type: none"> <li>- Voltage too low.</li> </ul>	<p>Charge battery, if necessary contact a workshop authorized by Volvo.</p>

**NOTE!**

If you are unable to remedy the error or fault, contact a workshop authorized by Volvo.

### Winter season preparation for auxiliary heater

Operator should exhaust remaining summer diesel in fuel line of auxiliary heater before winter season comes. Remaining summer diesel can cause plugging in fuel line if temperature drops in sudden because of wax crystallization. Run auxiliary heater at least 15 minutes until remaining diesel is exhausted.

When operator runs machine in winter season, it is recommended to fill fuel tank over 70%. If fuel tank has much empty space, it makes moisture inside of fuel tank. It can go to fuel line of auxiliary heater and frozen moisture sometimes makes fuel feeding problem.

### Fuel quality requirements for auxiliary heater

If the heater is run from a separate fuel tank, comply with the following rules.

- If ambient temperatures over 0 °C;  
Use diesel fuel according to DIN EN 590.
- If ambient temperatures from 0 °C to -20 °C;  
Use winter diesel fuel according to DIN 590.
- If ambient temperatures from -20 °C to -40 °C;  
Use Arctic diesel or Polar diesel.

#### NOTE!

- Used oil is not allowed.
- After refuelling with winter or cold diesel or the listed blends, the fuel pipes and the metering pump must be filled with the new fuel by letting the heater run for 15 minutes.
- Volvo does not recommend mixing Kerosene with diesel due to unstable combustion which causes decrease of durability of auxiliary heater and makes bad exhaust gas.
- Volvo recommends to use commercial additives which improve wax crystallization of diesel fuel in cold weather if it is difficult to use Arctic diesel or Polar diesel.





### Operation with bio-diesel fuel

The heater is approved for operation with bio-diesel up to a temperature of -8 °C (the flowability reduces at temperatures below 0 °C).

#### NOTE!

- If operated with bio-diesel (100% operation and blends), the heating output of the heater reduces.
- A reduced heater life is to be expected if constantly operated with 100% bio-diesel.
- Standard diesel fuel contains up to 20% bio-diesel. This does not have any effect on the life of the heater.

Contact a workshop authorized by Volvo for detailed information.

## Auxiliary heater

(Optional equipment)

### WARNING

Risk of fire and explosion.

A running auxiliary heater in the immediate vicinity of flammable gases, fumes, liquids or dust could cause fire and explosion.

**Do not use the auxiliary heater if the machine is in an environment in which flammable gases, fumes, liquids or dust are present or could be present.**

### DANGER

Risk of suffocation.

Exhaust fumes from the auxiliary heater contain carbon monoxide, a colorless, odorless gas, which is fatal when inhaled in a confined area.

**Do not use the auxiliary heater if the machine is located in enclosed rooms without proper ventilation.**

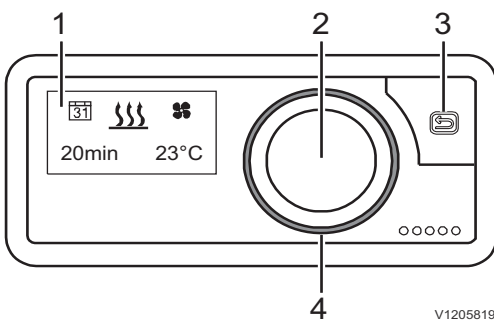

- 1 Display
- 2 Operating button
- 3 BACK button
- 4 LED ring

The auxiliary heater timer is used to select the operation mode, for setting the operating time, for preselecting the starting time and for switching the heater ON or OFF.

### 1. Display

The display shows the following parameters:

- Current operating mode
- Current interior temperature
- Operating mode
- Timer positions
- Settings
- Error messages

## 2. Operating button

The operating button is used to operate, select and program all the functions and values in the auxiliary heater timer.

**Turning** selects a value/function within a menu.

- Turning to the right increases a value or selects the next menu item to the right.
- Turning to the left decreases a value or selects the next menu item to the left.
- If the timer is in sleep mode (display OFF), pressing or turning “wakes up” the active display mode.

If the heater is switched off, the Start mask will be displayed.

- When the heater is running, the currently remaining operating time of the heater is displayed.

### NOTE!

- A LONGPRESS (minimum 2 seconds) immediately starts the heater. The standard operating time is set at the factory to 30 minutes.
- During operation, a LONGPRESS (minimum 2 seconds) immediately switches off the heater.

## 3. BACK button

The BACK button causes a jump back to the menu or command at the next higher level. If the timer is in sleep mode (display OFF), pressing “wakes up” the active display mode.

- If the heaters is switched off, the Start mask will be displayed.
- When the heater is running, the currently remaining operating time of the heater is displayed.

## 4. LED ring

The LED ring indicates the different operating modes with different colors.

- Red ring: Heating mode
- Blue ring: Ventilation mode
- Orange ring: Residual heat mode
- White ring: System configuration
- Red flashing ring: Fault in the heater or in the timer.

### Operation and settings

#### Activating the timer

If the display is not lit, the timer has to be activated. Pressing the operating button or BACK button  displays the Start mask.

#### Display

The display is lit:

- During operation of the timer
- When the heater is ON (the display goes out after approx. 30 seconds).

Display goes out:

- No settings are made.
- No heater is switched on.

The timer then goes to sleep mode. Before going to sleep mode, an overview mask is displayed. The timer has to be activated (see above) before a new input can be made.

#### Activating a function

The symbol of the function to be activated appears in the middle and flashes in the display.

Flashing function / flashing value

- Select the flashing function in the menu bar by pressing the operating button.
- Increase or decrease the flashing value by turning the operating button. Then confirm the selected value by pressing the operating button.

#### Cancel settings

Any settings being made can be cancelled with the BACK button .

#### NOTE!

Settings and changes must always be confirmed by pressing the operating button, otherwise they will be lost.

#### Setting the operating time

The operating time can be set individually using the operating button.

- Turning to the right increases the operating time.
- Turning to the left decreases the operating time.
- Setting range for the operating time:  
minimum 10 minutes to maximum 120 minutes in one minute steps.

- The operating time can be prolonged to infinite. Above the 120th minute, the input is made in 60-minute steps.

### Operating modes

#### Heating mode

In this mode, the heater heats the vehicle engine via the coolant circuit and the cab via the HVAC system (Heating, Ventilation, Air Conditioning).

#### Ventilation mode

In this mode, the heater supplies the cab with fresh outdoor air via the HVAC system (Heating, Ventilation, Air Conditioning).

#### Residual heat mode

In this mode, the heating system uses the residual heat in the coolant circuit of the warm engine and distributes heated air in the cab.

### Menus and functions

#### Menu Bar

The following menus can be selected from the menu bar (turn the operating button to the right):

Symbol	Function
	Heat
	Ventilate
	Residual heat
	Settings
	Timer

#### Status area

When the menu (heating, ventilation, settings, timer or residual heat) is activated, various items of information are displayed in the status area.

#### Input area

In the menu bar, the symbol of the selected menu item appears in the middle of the display. The corresponding setting value flashes in the input area and can be altered by turning the operating button to the left or right and confirmed by pressing.

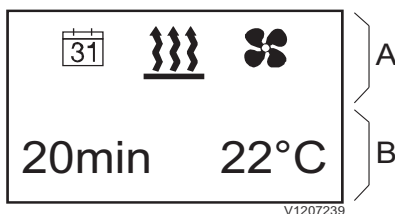

- A Menu bar
- B Status area

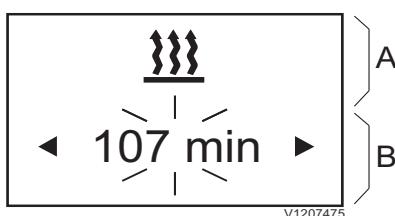

Example: Heating ON, operating time 107 minutes

- A Menu bar
- B Input area

148 Other controls  
Operator comfort

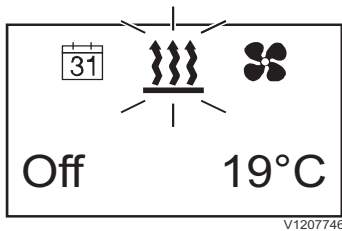

Start mask, heating

### Heating

In the Start mask, a flashing heater symbol in the menu bar and the current temperature and status of the heater are displayed.

Possible actions are:

- Heating immediately with LONGPRESS
  - Press operating button for longer than 2 seconds.
  - Heating mode starts immediately with the last operating time used. The LED ring lights up red and the residual heating mode time is displayed.

#### NOTE!

The function LONGPRESS ON is not available in ventilation and residual heat mode.

- Heating ON with settings
  - Press the operating button.
  - Select the operating time by turning the operating button.
  - Confirm the operating time by pressing the operating button.
  - Heating mode starts with the set operating time. The LED ring lights up red, the residual heating time and the current temperature are displayed.
  - Heating mode ends at the end of the set operating time.

Changing the operating time during heating mode:

- Press the operating button.
- Select and confirm flashing menu .
- Select and confirm the settings by turning and pressing the operating button.
- Set the desired operating time by turning and press to confirm.
- Heating mode is continued with the set operating time. The LED ring lights up red and the residual heating mode time is displayed.

HEATING OFF during heating mode:

- Press the operating button.
- Select and confirm flashing menu .
- When OFF flashes on the display, press the operating button again.
- Heating mode is terminated.

#### NOTE!

LONGPRESS terminates heating mode immediately and the heater is also switched off.

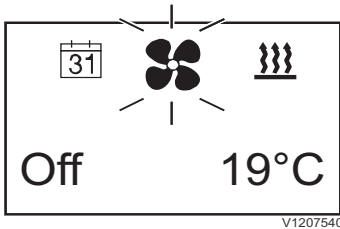



Start mask, ventilation

### Ventilation

In the Start mask, a flashing fan symbol  in the menu bar and the current temperature and status of the heater are displayed.

- Press the operating button.
- Select the operating time by turning the operating button and confirm, or confirm the displayed operating time.
  - Ventilation mode starts with the set operating time. The LED ring lights up blue and the residual ventilation mode time is displayed.
- Ventilation mode ends at the end of the set operating time.

Changing the operating time during ventilation mode:

- Press the operating button.
- Select and confirm flashing menu .
- Select and confirm the settings  by turning and pressing the operating button.
- Set the desired operating time by turning and press to confirm.
  - Ventilation mode is continued with the set operating time. The LED ring lights up blue, the residual ventilation mode time and the current temperature are displayed.

Ventilation OFF during ventilation mode:

- Press the operating button.
- Select and confirm flashing menu .
- When OFF flashes on the display, press the operating button again.
- Ventilation mode is terminated.

### NOTE!

LONGPRESS terminates ventilation mode immediately and the heater is also switched off.

150 Other controls  
Operator comfort

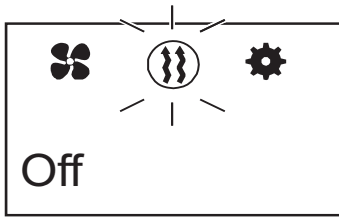

Start mask, residual heat

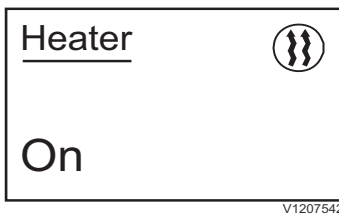

Residual heat mode ON

**Residual heat mode**

In the Start mask, a flashing heater symbol in a circle (ⓘ) in the menu bar and the current status of the heater are displayed.

In the residual heat mode, the heating system uses the residual heat in the coolant circuit of the warm engine and distributes heated air in the cab.

In this operating mode, only the water pump and fan are in operation.

**NOTE!**

Residual heat mode cannot be used if the coolant temperature is too low.

**Residual heat mode ON**

- Press the operating button and select ON.
  - Residual heat mode starts if there is residual heat in the engine coolant.
  - The LED ring lights up orange. The operating time of the heating mode depends on the available residual heat.
  - The operating status and mode of the heater appear on the display.

**Residual heat mode OFF**

- Press the operating button and select OFF.
  - Residual heat mode stops.

**NOTE!**

LONGPRESS stops the residual heat mode immediately.



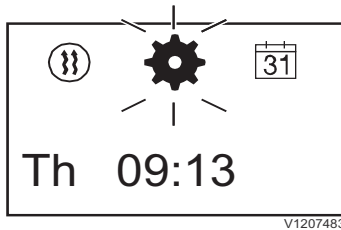

Start mask, settings

### Settings

In the Start mask, a flashing gear wheel  in the menu bar and the set day of the week and the current time are displayed.

Possible actions are:

- Standard settings for day of the week, time and temperature format
- Heating at high altitudes: ON / OFF
- Low temperature during heating: ON / OFF
- Fault diagnosis: Display of error messages
- Reset user settings

### Standard settings

Set time:

-  Select and confirm.
- Set the hours and confirm.
- Set the minutes and confirm.

Set time format:

-  Select and confirm.
- Select between 12 h and 24 h format and confirm.

Set weekday:

-  Select and confirm.
- Set the day of the week and confirm.

Set temperature format:

-  Select and confirm.
- Select between degrees Celsius and degrees Fahrenheit and confirm.

### Low temperature heating mode

The low temperature heating mode is a comfort function at higher outdoor temperatures.

The function modifies the control thresholds of the heater in order to harmonize heating mode, e.g. in the summer months.

-  Select and confirm.
- Select between ON and OFF and confirm.

### Resetting the user settings

-  Select and confirm.
- YES resets the user settings in the timer and deletes the programmed times, date and other settings.
- NO retains the existing user settings in the timer.



### Timer

The timer selection menu controls up to three programmable timer positions. The timer positions can either all take place on one weekday or can be distributed between different weekdays or weekday ranges.

Weekday ranges, e.g.

Monday – Friday: 5 x heat

Monday – Sunday : 7 x heat

If a programmed weekday range is activated, all the days of the week are processed in turn as long as the timer is active. Renewed programming is not necessary.

#### **NOTE!**

- If the timer is activated with a programmed weekday range Monday – Friday on Sunday, the heater heats from the following Monday to Friday with the set defaults. (5x heating)
- If the timer is activated with a programmed weekday range Monday – Friday on Wednesday, the heater heats on Wednesday, Thursday and Friday. In the following week, operation is continued with the set defaults on Monday and Tuesday. (5x heating)
- When a weekday range has been processed, the time position has to be reactivated for the following week.

The heater starts on the selected day on reaching the set starting time.

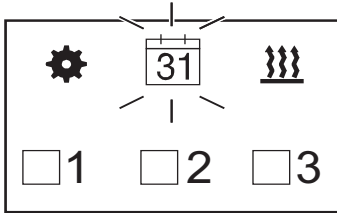

V1207486

Display if no timer is activated.

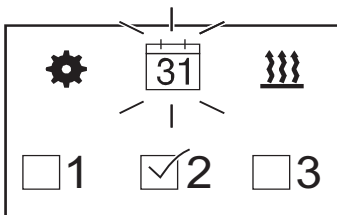

V1207487

Display if a timer is activated, here T2.



V1207488

T1 with factory settings

### Programming the timer

- Display ON, the Start mask appears.
- Select in the menu bar with the operating button.
- Confirm timer selection by pressing the operating button.  
The first timer position T1 appears. Turn the operating button to select the alternative timer positions T2 or T3.
- The factory settings are:
  - Heating mode
  - Weekday range Monday – Friday
  - Starting time: 7:00 h
  - Operating time: 30 minutes
- Call up timer T1 by pressing the operating button.  
You are now in configuration mode.

### NOTE!

The heater is connected to the battery, the operating time of the heater should not exceed the following working time of the machine. This will ensure that the battery is sufficiently charged.

Example:

Operating time of the heater: 25 minutes

Working time of the machine: minimum 25 minutes

## 154 Other controls Operator comfort

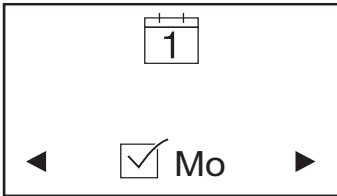

V1207489

Operating day

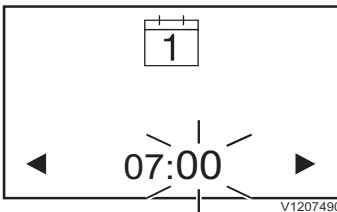

V1207490

Starting time

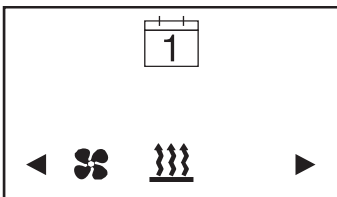

V1207491

Operating mode



V1207492

Operating time

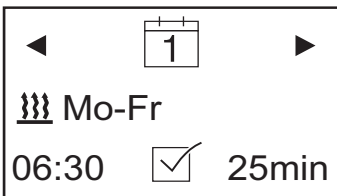

V1207493

T1 settings

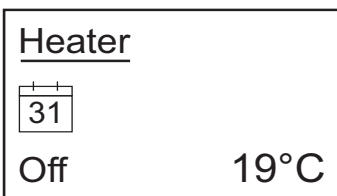

V1207539

Timer activated

### Possible settings

- Timer T1 ON / OFF by turning and pressing the operating button.
- After selecting ⚙️ in the menu bar, select the day of the week / weekday range by turning the operating button.

Each day of the week is selected individually and confirmed by pressing. Pressing a second time deselects the day of the week again.

At the end of the selection, turn the operating button to [OK] and press to confirm.

- Setting the starting time.  
Turning and pressing confirms first the hour, then the minutes.

- Selection of heating or ventilation mode.

- Select the operating time.  
minimum 10 minutes – maximum 120 minutes

- After activation of timer T1, the following appears on the display:

- Heating mode
- Weekday range Monday – Friday
- Starting time: 6:30 h
- Operating time: 25 minutes

- Timer T1 is activated. The heater will be started at the set time on the next working day and will run for 25 minutes.

- If a timer is activated, the timer symbol appears on the display.



Timer positions T2 and T3 can be configured in the same way.

**NOTE!**

To edit an existing timer, first select the timer and then press the operating button to switch to configuration mode. Then carry out the steps as described above.

**Deactivate timer**

To deactivate a timer position, first select the timer with the operating button. Press once and with OFF flashing, press the operating button again. All operating settings of the timer remain saved.

**NOTE!**

When a weekday range has been processed, the time position has to be reactivated for the following week.

156 Other controls  
Operator comfort

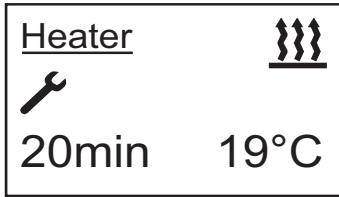

V1207484

**Fault diagnosis**

If a fault occurs, the symbol  appears on the display during operation.





The LED ring flashes red as soon as a fault occurs. It stops flashing when the error message has been cancelled by pressing the operating button.

Fault diagnosis can also be called up with the function  in menu .

- Select  and confirm.
- Select and confirm the heater or timer.
- The faults are displayed in the order of their occurrence.







Further information see table below.

**Possible error messages on the display**

Display	Description	Remedy
 Service V1205824	Fault in the heater.	Contact a qualified service technician.
 Undervoltage V1205825	Undervoltage applied at the heater control box without interruption for at least 20 seconds.	Check battery for a drop in voltage. Charge the battery, if necessary contact a qualified service technician.
 Overvoltage V1205826	Overvoltage applied at the heater control box without interruption for at least 20 seconds.	Check battery, if necessary contact a qualified service technician.
 Fuel Supply or Pump V1205827	Fault in the fuel supply or fuel pump.	Check the fuel line to the heater for free passage. Check cables for continuity, short circuit and damage. Pull the plug off the fuel pump and inspect for damage. Check the fuel level in the fuel tank. Contact a qualified service technician.



Other controls  
**Operator comfort 157**

Display	Description	Remedy
 Water Circuit or Pump  <small>V1205828</small>	Water temperature in the heater too high.	Check the water pump for proper function. Check the water circulation in the water circuit. The heater can be reset to the delivery condition by removing the heater fuse. Contact a qualified service technician.
 Overheat. Heater locked.  <small>V1207217</small>	Overheating of the heater detected. The heater is interlocked for safety reasons.	Check the heater and the water circuit for leaks. The heater can be reset to the delivery condition by removing the heater fuse. Contact a qualified service technician.
 Restricted Operation  <small>V1207218</small>	Emergency running of the heater.	There is a fault in the heater. Restricted operation is still possible. Contact a qualified service technician.
 Ext. Temp. Sensor defective  <small>V1207219</small>	The external temperature sensor is defective.	Contact a qualified service technician.
 Int. Temp. Sensor defective  <small>V1207220</small>	The internal temperature sensor is defective.	Contact a qualified service technician.
 Rotary Knob jammed  <small>V1207221</small>	The operating button is blocked.	Can the operating button be freed again by hand? Contact a qualified service technician.



158 Other controls  
Operator comfort

Display	Description	Remedy
<div style="border: 1px solid black; padding: 5px; text-align: center;"> <p>◀ 4 ▶</p> <p>Pushbuton jammed</p> <p><small>V1207222</small></p> </div>	The button is blocked.	Can the button be freed again by hand? Contact a qualified service technician.
<div style="border: 1px solid black; padding: 5px; text-align: center;"> <p>◀ 7 ▶</p> <p>Timer mode not allowed</p> <p><small>V1207223</small></p> </div>	Timer mode is not permitted during ADR mode. (a)	Contact a qualified service technician.
<div style="border: 1px solid black; padding: 5px; text-align: center;"> <p>◀ 8 ▶</p> <p>Operation not supported</p> <p><small>V1207224</small></p> </div>	The heater is in auxiliary heating mode via Switching Plus and cannot be operated via Timer control unit during this time.	Contact a qualified service technician.
<div style="border: 1px solid black; padding: 5px; text-align: center;"> <p>◀ 9 ▶</p> <p>CAN communication error</p> <p><small>V1207225</small></p> </div>	Communication error on the CAN bus link.	Contact a qualified service technician.

a) ADR mode is reserved for vehicles transporting hazardous goods on the road. Not applicable for the machine.

**NOTE!**

If you are unable to remedy the error or fault, contact a qualified service technician.

**Winter season preparation for auxiliary heater**

Operator should exhaust remaining summer diesel in fuel line of auxiliary heater before winter season comes. Remaining summer diesel can cause plugging in fuel line if temperature drops in sudden because of wax crystallization. Run auxiliary heater at least 15 minutes until remaining diesel is exhausted.

When operator runs machine in winter season, it is recommended to fill fuel tank over 70%. If fuel tank has much empty space, it makes moisture inside of fuel tank. It can go to fuel line of auxiliary heater and frozen moisture sometimes makes fuel feeding problem.



## Fuel quality requirements for auxiliary heater

If the heater is run from a separate fuel tank, comply with the following rules.

- If ambient temperatures over 0 °C;  
Use diesel fuel according to DIN EN 590.
- If ambient temperatures from 0 °C to -20 °C;  
Use winter diesel fuel according to DIN 590.
- If ambient temperatures from -20 °C to -40 °C;  
Use Arctic diesel or Polar diesel.

### NOTE!

- Used oil is not allowed.
- After refuelling with winter or cold diesel or the listed blends, the fuel pipes and the metering pump must be filled with the new fuel by letting the heater run for 15 minutes.
- Volvo does not recommend mixing Kerosene with diesel due to unstable combustion which causes decrease of durability of auxiliary heater and makes bad exhaust gas.
- Volvo recommends to use commercial additives which improve wax crystallization of diesel fuel in cold weather if it is difficult to use Arctic diesel or Polar diesel.

## Operation with bio-diesel fuel

The heater is approved for operation with bio-diesel up to a temperature of -8 °C (the flowability reduces at temperatures below 0 °C).

In case of storage periods longer than 30 days it is advisable to use FAME-free products, as ageing effects can have a negative effect on the fuel, especially regarding its flow properties and filterability.

### NOTE!

Blending with max.30% FAME according to EN14214 is permitted.



## Operating instructions

This chapter contains rules which must be followed in order to operate the machine safely. However, these rules are to be followed in conjunction with laws or other national regulations applicable to road safety and labour welfare.

Alertness, judgement and respect for applicable safety regulations are conditions for avoiding risk of accidents.

### Running-in instructions

During the first 100 hours, the machine should be operated with a certain care. It is important to check oil and fluid levels often during the running-in period.

## Visibility

### **WARNING**

Risk of serious accidents.

Machine parts, equipment or load could obstruct the operator's view. Operating or driving with obstructed operator's view could cause serious accidents.

**Use a signal man if operator's view is obstructed.**

It may not be possible to provide direct visibility to all areas around the machine. To achieve acceptable visibility, additional devices such as warning systems, mirrors, and closed-circuit television cameras (CCTV) may be used.

In order to minimize hazards that may be caused by restricted visibility, rules or procedures shall be established by the job site management. For example:

#### **NOTE!**

Some parts of the basic machine may restrict visibility, for example, the cab's pillars, frames, exhaust pipe, engine hood, as well as optional equipment such as buckets, pallet forks, grapples, and so on. The load that is handled with these attachments may also restrict visibility.

- Ensure that operators and job site workers have received thorough safety instructions.
- Control the traffic patterns for the machine and other vehicles. Avoid travelling in reverse if possible.
- Restrict the machine's operating area.
- Use a signman to help the operator. Use signals according to the signal diagram, see page 256.
- Provide two-way communication equipment if necessary.
- Ensure that job site workers communicate with the operator before approaching the machine.
- Use warning signs.



## Operating instructions

162

---

Standard ISO 5006 "Earthmoving machinery- Operator's field of view" deals with the operator's visibility around the machine and is meant to be used for measuring and evaluating the visibility.

The machine is tested by methods and performance criteria according to this standard. The visibility method used may not include all aspects of the operator's visibility, but provides information for determining if additional devices for indirect visibility, such as warning systems, are necessary.

The test was performed on machines with standard equipment and attachment. If the machine is modified or fitted with other equipment or attachment, which results in impaired visibility, it should be re-tested according to ISO 5006.

If other equipment or attachments are used and the visibility has been impaired, the operator should be informed.

Conforming to the standard is a requirement in EU-countries and provides for improved visibility around the machine.

## Mirror and camera (if installed) settings

### Mirrors, adjusting

ISO 5006 states that an imaginary boundary line around the machine must be visible to the operator.

- Park the machine straight and on level ground.
- Adjust the mirrors until the imaginary boundary line is visible to the operator, see figure below.

### NOTE!

Cameras may be also used to create visibility on the rectangular boundary. (Cameras are not adjustable on the machine.)

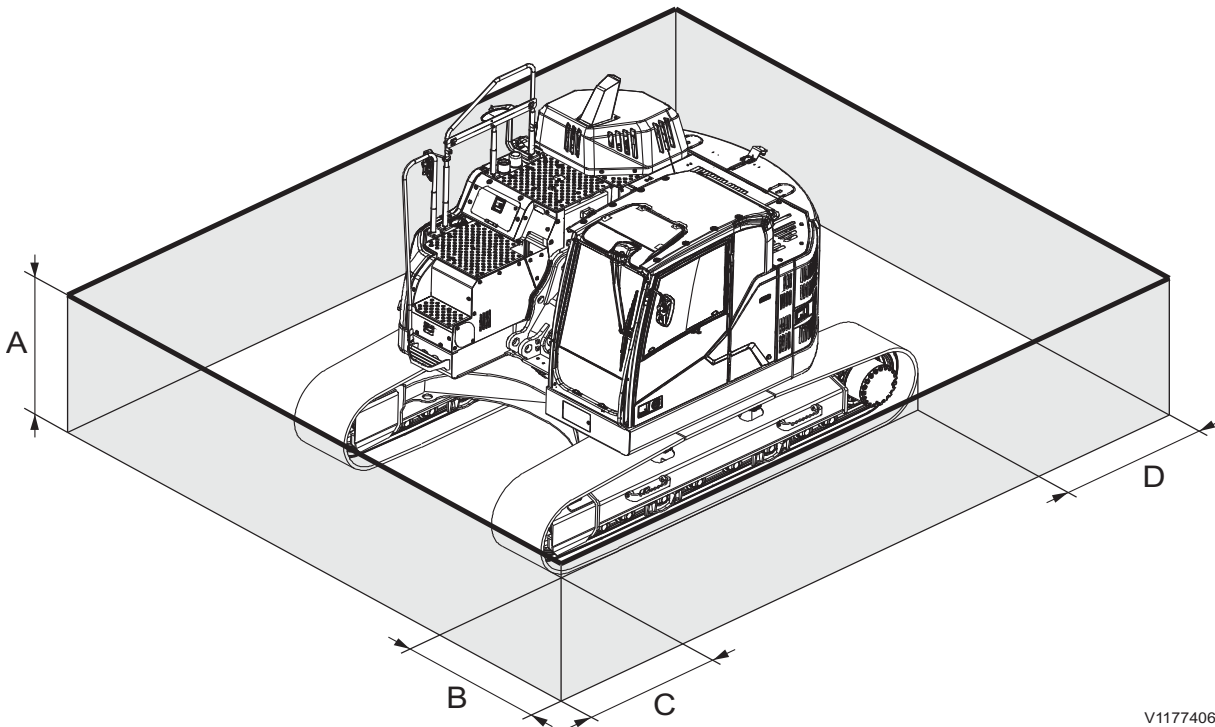

Close-up visibility boundary according to ISO 5006 (thick line)

- A 1.2 m (47.2 in)
- B 1.0 m (39.4 in)
- C 1.0 m (39.4 in)
- D 1.0 m (39.4 in)

V1177406

Operating instructions

164

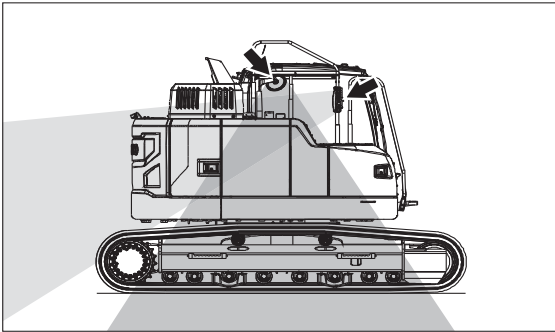

V1177432

Machine's right view

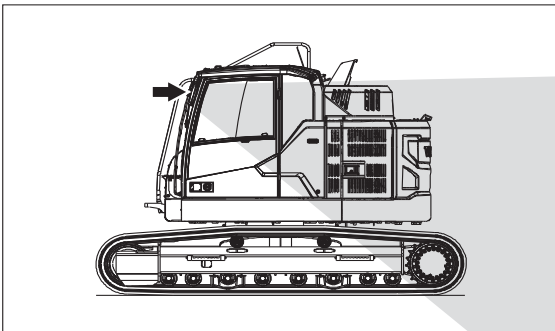

V1177433

Machine's left view

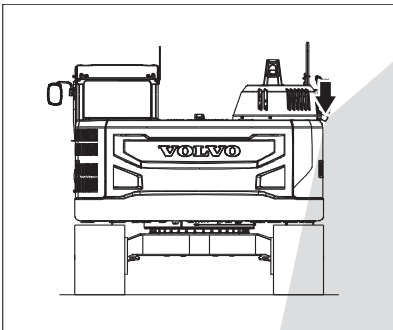

V1177435

Machine's rear view

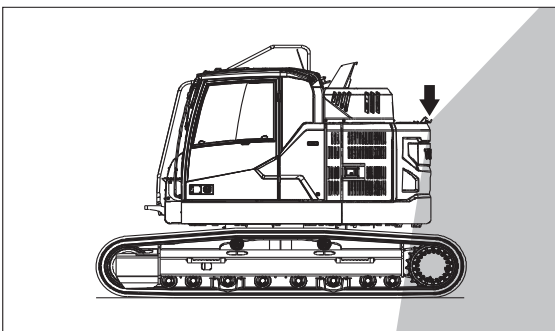

V1177436

Machine's left view

Rear-view mirrors

Using the rear-view mirrors, check that you have as good visibility as possible towards the machine's superstructure and lower frame, and with as wide angle as possible. If not, adjust the rear-view mirrors until good visibility is obtained, see figures.

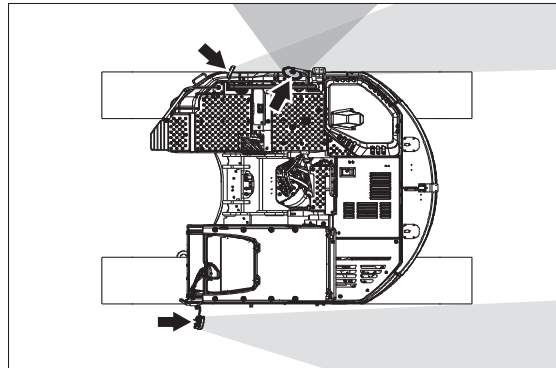

V1177434

Machine's top view

Rear-view and Side-view cameras (if installed)

Check the rear-view and side-view camera's display screens, which are focused on the visible areas, for good visibility.

**NOTE!**

Cameras are not adjustable on the machine.

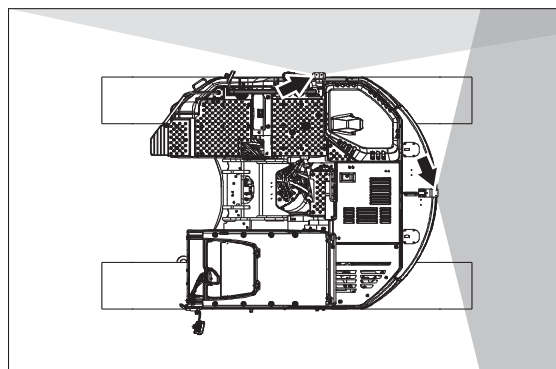

V1177437

Machine's top view



### Measures before and during operation

- Walk around the machine and check that there are no obstacles next to the machine.
- Check that mirrors and other visibility-enhancing devices are in good condition, clean, and correctly adjusted.
- Clean the cameras, if cameras are installed.

#### NOTE!

When you have direct access to the cameras for cleaning, be sure to use an appropriate external ladder or an appropriate platform.

- Check that the horn, back-up/travel alarm and rotating beacon (optional equipment) are working correctly.
- Check if the management has established rules or procedures for the work site.
- Always pay attention around the machine to identify any obstacles.
- Prevent persons from entering or remaining in the work area, i.e., the area around the machine and at least 7 m (23 ft) beyond the maximum reach of the attachment. However, depending on the job site's organization, the operator may allow a person to remain in the work area, but must then observe caution and operate the machine only when the person can be seen or has given clear indications of where he or she is.  
Never allow any person to walk or stand under raised equipment or suspended loads.

## Safety rules when operating

### Operator obligations

#### **WARNING**

Risk of fatal accidents.

Unauthorised persons within the work area around the machine could lead to serious crushing injury.

- **Clear all unauthorised personnel from the working area.**
- **Keep a lookout in all directions.**
- **Do not touch control levers or switches during start.**
- **Sound the horn before beginning operation.**
- The operator must operate the machine in such a way that the risk of accidents is minimized for both the operator and persons present on the work site.
- The operator must be thoroughly familiar with how to operate and maintain the machine and should undergo adequate training on the machine.
- The operator must follow the rules and recommendations in the Operator's Manual, but must also pay attention to any legislation and national regulations or specific requirements or risks that apply at the work site.
- The operator must be thoroughly rested and must never operate the machine when under the influence of alcohol, medicine, or other drugs.
- The operator is responsible for any load while working with the machine.
  - There must be no risk of the load falling off while operating.
  - Refuse to take a load which is an obvious safety risk.
  - Respect the stated maximum load for the machine. Pay attention to the effect of different distances to the centre of gravity and the effects of different attachments.



## Operating instructions Safety rules when operating 167

- The operator must check that the mirrors and cameras (if installed) are in good condition, clean, and adjusted correctly for good visibility before operating the machine.

**NOTE!**

Cameras (if installed) are not adjustable on the machine. Check that the camera screen is displayed correctly on the IC (Instrument Cluster) when pressing the camera button on the keypad.

- The operator must be in control of the machine's work area.
  - Prevent persons from walking or standing under raised excavating equipment or suspended loads, unless it has been made safe or supported.
  - Prevent persons from entering or remaining in the work area, i.e., the area around the machine and at least 7 m (23 ft) beyond the maximum reach of the attachment. However, depending on the job site's organization, the operator may allow a person to remain in the work area, but must then observe caution and operate the machine only when the person can be seen or has given clear indications of where he or she is.
  - Prevent persons from being in the cab of a vehicle that is in a location with a risk that the cab may be hit by other machines or falling objects, for example, stones or logs. This does not apply if the cab is sufficiently strong or is protected to withstand the impact of such external forces.
  - Make sure that you know the weight limitation of the ground on which the machine is working.

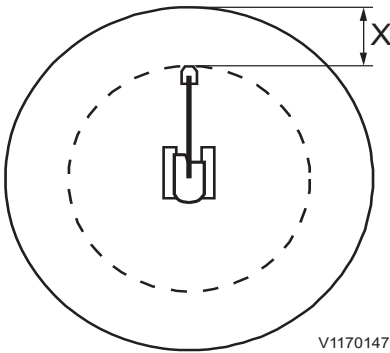

V1170147

The operator may only take an instructor on board, if there is an approved instructor's seat in the machine.

**WARNING**

Risk of fatal accidents.

Using attachments for lifting or transporting persons may lead to fatal accidents with serious crushing injury or death.

**Never use attachments for lifting or transporting persons.**



## Accidents

- Accidents and also incidents should be reported to the site management immediately.
- If possible leave the machine in position.
- Only take necessary action so as to reduce the effect of damage, especially personal injuries. Avoid action which may make an investigation more difficult.
- Wait for further instructions from the site management.

## Operator safety

- The machine must be operational, that is faults which can cause accidents must be rectified.
- Suitable clothing for safe handling and a hard hat should be worn.
- Mobile phone should not be used when operating the machine. Follow all national regulations for mobile phone use during operation!
- Always sit in the operator seat when starting the engine/machine.
- Keep your hands away from areas where there is a risk of crushing, for example covers, door and window.
- Always use the seat belt.
- Check that the seat belt is not damaged or worn.
- Use steps and handholds when entering or leaving the machine. Use the three-point grip, that is two hands and one foot or two feet and one hand. Always face the machine - do not jump!
- The door must be closed.
- Check that the attachment is properly attached and locked.
- The vibration (shaking) which arises when operating may be harmful to the operator. Reduce this by:
  - adjusting the seat and tightening the seat belt.
  - picking the smoothest operating surface for the machine (levelling the surface when necessary).
  - adapting your speed.
- In case of travelling on uneven ground, do not let the machine lean more than 10° to one side.
- The cab has two emergency exits, the door and the rear window.
- Only walk and step on surfaces which are provided with anti-slip protection.



## Operating instructions Safety rules when operating 169

---

- During electrical storms, do not attempt to enter or exit the machine.
  - If you are off the machine, stay well away from the machine until the storm passes.
  - If you are in the cab, remain seated with the machine stationary until the storm passes. Do not touch controls or anything metal.
- In all kinds of works (travelling, digging, loading, hammering, and so on), place the idler side in front to reduce the travel drive damage due to incorrect operating position.
- When DPF regeneration;
  - Make sure that there is no flammable material around the machine, this is important to prevent risk of fire.
  - Move the machine to safety area, if there is a risk that people may get too close and then perform the regeneration.

### **WARNING**

**Risk for fire.**

**Regeneration generates hot exhaust and causes hot exhaust pipe. Do not perform regeneration in a flammable environment.**



## 170 Operating instructions Safety rules when operating

---

### Operating on public roads

- Road signs, traffic restricting arrangements and other safety devices, which may be required when considering traffic speed and intensity or other local conditions, must be used.
- When moving the machine with a suspended load, special attention must be observed. when required, request the help of a signal man.
- Warning beacon may be used:
  - On attached or connected implement, which is wider than the vehicle itself.
  - When the vehicle constitutes a hindrance or danger to other traffic.
  - When working on or by the side of the roadway.

## Measures before operating

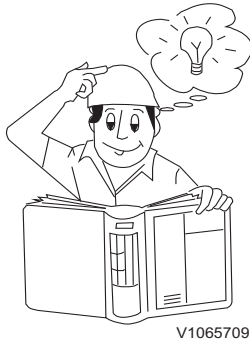

### NOTICE

The safety regulations and operating instructions issued by the manufacturer must be strictly observed.

- Read the Operator's manual.
- Carry out daily service, see page 281. In cold weather, make sure that the freezing point of the coolant is sufficiently low and that the lubricating oil is intended for winter use.
- Clean / scrape ice off the windows.
- Clean the dust around engine, battery and cooler.
- Check the level of hydraulic fluid, refill if required.
- Check that there is sufficient fuel in the fuel tank.
- Check that there are no faulty, loose parts or leaks, which can cause damage.
- Check that the battery disconnected switch is switched on.
- Check for cracks on frame and tracks.
- Check that hoods and covers are closed.
- Make sure fire extinguisher if equipped is fully charged.
- Inspect steps and handholds for damage or loose parts. Make necessary repairs if needed.
- Check that there are no persons in the vicinity of the machine.
- Adjust the operator seat and fasten the seat belt.
- Adjust and clean the mirrors.
- Inspect working and other lights for proper operation.
- Travel alarm should be on before operating the machine.
- Inspect the failure of gauges in the instrument panels.
- Check the function of the attachment quick coupler (optional equipment).

172 Operating instructions  
Starting engine

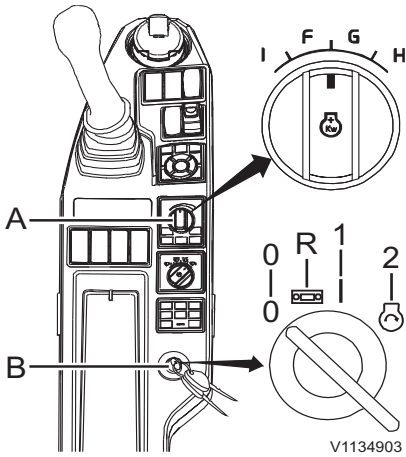

A Engine speed control switch  
B Ignition switch

- Off position (0)
- Radio position (R)
- Operating (preheating) position (1)
- Start position (2)

## Starting engine

### NOTE!

Make sure the control lockout lever is in downward (lockout) position, otherwise the engine can not be started.

### WARNING

Risk of fatal accidents.

Unauthorised persons within the work area around the machine could lead to serious crushing injury.

- Clear all unauthorised personnel from the working area.
- Keep a lookout in all directions.
- Do not touch control levers or switches during start.
- Sound the horn before beginning operation.

### NOTICE

Do not keep the ignition switch in starting position for more than 20 seconds, as this may seriously damage the starting system. If the engine does not start, turn the switch back to stop position and wait a couple of minutes before the next starting attempt.

### NOTICE

If the engine sounds or runs strangely or if strong vibrations arise, the ignition switch must be turned to stop position immediately.

### NOTICE

Wait until the electronic system is completely shut down before restarting.

- 1 Turn the engine speed control switch (A) to the low speed position and turn the key to operating position.
- 2 Sound the horn and let other workers and bystanders know you are starting the machine. For the startup sequence, see page 44.
- 3 Turn the key to the start position.
- 4 Release the key when the engine has started.
- 5 Warm up the machine.



V1065729

Preheating indicator

## Starting engine in cold weather

- 1 Turn engine speed control switch (A) to the low speed position.
- 2 Turn the key to the running (preheating) position and keep it there while the preheating is working. The preheating indicator will be displayed on the indicator screen of IC (Instrument cluster).
- 3 When the preheating is finished, sound the horn and let other workers and bystanders know you are starting the machine.
- 4 Turn the key to the starting position.
- 5 Release the key when the engine has started.
- 6 Warm up the machine. Run at low speed and with a light load until the oil in the engine and hydraulic system has warmed up.

### **NOTICE**

Run the engine at low idling speed for 10–15 minutes to warm the engine and the hydraulic system at temperatures below  $-15^{\circ}\text{C}$  ( $+5^{\circ}\text{F}$ ) before putting the machine to work.

Use recommended lubricating oil for winter use. See page 338.

During the cold season, fill the fuel tank after work has finished for the day to counteract the formation of condensation water in the tank.

174 Operating instructions  
Starting engine

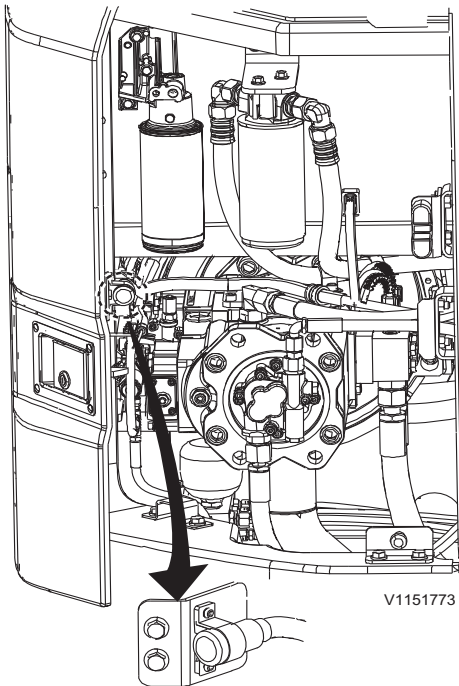

Socket for block heater

## Engine block heater

(optional equipment)

This equipment is used to reduce the engine load which cause the wear in the engine when starting the machine in cold weather region.

### **NOTICE**

The machine may be equipped with cylinder block heater for either 120 V or 240 V. Compare the specified voltage of the external power supply and with that of the cylinder block heater.



## Starting with booster batteries

### **WARNING**

Risk of explosion.

Batteries could explode due to the current surge if a fully charged battery is connected to a completely discharged or frozen battery.

**Do not boost start a machine with a completely discharged or frozen battery.**

When starting with booster batteries, check that the booster batteries or other power source have the same voltage as the batteries of the machine. If the batteries in another machine are used the engine of that machine must be turned off.

### **NOTICE**

**Do not attempt to start the engine while the battery charger is still connected to the mains. This may cause serious damage to the electronic control units.**

- 1 Turn OFF the battery disconnect switch.
- 2 Remove the protections from the battery pole studs.

**Connect two 12 V batteries as follows :**

- 3 Connect one of the jump leads between (+) terminal on the battery of the machine and the (+) terminal on the booster battery.
- 4 Connect the other jump lead between the (-) terminal of the booster battery and a grounding point on the machine.

### **NOTICE**

**Do not connect ground to the undercarriage on the machine. This may seriously damage the swing bearing.**



## 176 Operating instructions Starting engine

---

- 5 Connect the batteries of the machine by turning on the battery disconnect switch.
- 6 Start the engine with the ignition switch in a cab.
- 7 Leave the batteries connected for 5-10 minutes after starting the engine.
- 8 Disconnect the jump lead from the chassis connection on the machine, and then disconnect the other end of the jump lead from the (-) terminal on the booster battery.
- 9 Finally disconnect the jump lead between the (+) terminals.
- 10 Re-install the battery pole stud protections.

### Warming up

Machine may respond slowly at low temperatures. Operate carefully until the system has reached normal temperature. Otherwise unexpected movements may occur.

## Hydraulic system, warming up

The oil in machine's hydraulic system is used for operating the hydraulic cylinders of the equipment as well as the hydraulic motors for travelling and swinging. When the oil is cold it is viscous.

Therefore the machine's hydraulic functions operate slower than when the oil is warm.

Malfunctions may result if one or more of the machine functions are forced against end-position without first having warmed up the system.

### NOTE!

Operate the machine functions (travel, swing, and attachments) very slowly and carefully.

### WARNING

Risk of crushing injury.

The hydraulic system could respond slowly at low temperatures and could cause unexpected machine movements.

**Operate carefully until the hydraulic system has reached operating temperature.**

### NOTICE

**Do not rush warming of the oil, since forced warming can damage the machine.**

### WARNING

Risk of crushing.

Sudden movement of attachments may cause serious injury or death to personnel near the machine.

**Quick-acting controls operate the optional attachments. Operate the controls carefully.**

## 178 Operating instructions Hydraulic system, warming up

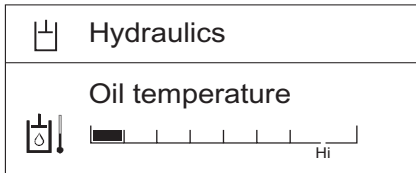

Hydraulic oil temperature screen

- 1 Start the engine and let it run at low idle for 5 minutes.
- 2 Then increase engine speed to approx. 1,200 rpm.
- 3 Carefully follow the instructions given below.
  - If the green bar for hydraulic oil temperature covers more than one gradation, perform the next steps 4 and 5.
  - If the green bar for hydraulic oil temperature covers less than one gradation, raise the boom slightly from the ground and operate bucket-in and bucket-out using the control lever for 5 minutes (stop operation for 2-3 seconds after 1 operation, i.e. bucket-in or out). After 5 minutes, if the green bar for hydraulic oil temperature has not reached one gradation, operate bucket-in using the control lever and hold the control lever in that position for 10 seconds to reach relief pressure. Release the control lever for 5 seconds and then repeat the operation until the green bar has reached one gradation.
- 4 Run out the bucket cylinder using the control lever and let the bucket move to its end-position.
- 5 Then carry out a number of boom, dipper arm, swing, and travel movements with the machine to distribute the warmed hydraulic oil to all hydraulic cylinders and motors.

Carry out these movements until the hydraulic system has reached working temperature/rapid working movements.

### Travelling a short distance

Moving the machine a short distance (for example, when loading onto or off a trailer) may be done without a complete warm-up. This operation must be done with great care. Under these conditions the engine speed must not exceed 1,200 rpm and the travel speed control should be in low speed position.



## Operating

### **NOTICE**

In order not to jeopardise the lubrication of the engine, the machine must not be inclined more than 35 degrees in either direction. In addition it may be unsuitable to operate at this inclination as the machine may become unstable and unbalanced, depending on the load.

### **NOTE!**

Do not jack the track up more than 35 degrees using attachment. Otherwise counterweight can be damaged.

### **NOTE!**

If the machine is equipped with travel warning system, a warning alarm sounds when levers or pedals are actuated.

For more operating information, see page 96.

## Exhaust aftertreatment system

### Regeneration

#### **WARNING**

Risk of burns.

Engine and exhaust system components get very hot and can cause severe burns.

**Avoid contact with engine compartment covers, engine components and exhaust system until the engine is cooled down.**

#### **NOTE!**

Some smoke might be seen coming from the exhaust stack during regeneration of the aftertreatment system on a machine run on diesel fuel with high sulfur content.

The purpose of regeneration is to raise the temperature in the aftertreatment system so that any trapped substances are burned off to allow the system to regain its full capacity.

#### **Normal operation**

During normal operation, passive regeneration occurs continuously.

#### **Parked regeneration**

Parked regeneration may be necessary if

- previous regeneration steps have failed or have been cancelled repeatedly
- too much time has passed since the last regeneration
- the aftertreatment system has accumulated excessive amounts of particles or sulphur

No work can be performed during a parked regeneration. The engine speed is raised during a parked regeneration. It is not advisable to cancel a parked regeneration which is in progress, except in an emergency.

To start a parked regeneration, the operator must stop the machine, lower the control lockout lever to

 Regeneration
<input type="radio"/> Stop
<input checked="" type="radio"/> Start

V1147263

## Operating instructions Exhaust aftertreatment system 181

lock the system and select "Start" in the regeneration menu on the IC (Instrument Cluster).

### NOTE!

The operator can start the regeneration immediately by pressing the SELECT button on the IC (Instrument Cluster) control keypad when an alarm indication for regeneration pops up on the IC (Instrument Cluster).

During regeneration, the HEST (High exhaust temperature) lamp is on, see symbol. This is to indicate that regeneration is in progress and that the exhaust temperature has increased. Do not turn off the engine while the HEST lamp is on.

### NOTE!

The machine must be in an area that is not heat-sensitive while the symbol is lit.

### Service regeneration

If a requested regeneration is delayed for too long, the PM (particulate matter)-load in the DPF (diesel particulate filter) and the amount of sulphur in the SCR (selective catalytic reduction) will be too high for a safe parked regeneration. Then regeneration must be started with Volvo's service tool in order to perform a safe regeneration.

### Fuel consumption

During a parked regeneration, the fuel consumption may increase.

### Delaying regeneration

The operator can delay the regeneration by pressing the ESC button on the IC (Instrument Cluster) control keypad when an alarm indication for regeneration pops up on the IC (Instrument Cluster). The alarm indication will pop up again after 15 minutes or when the engine is restarted. Delayed regeneration may be useful if the machine is in a heat-sensitive environment.

### NOTE!

**It is important to not delay regeneration unnecessarily.**

### Possible consequences of delaying regeneration:

- engine derate.
- higher fuel consumption.
- shorter diesel particulate filter service life.
- damage to the aftertreatment system.

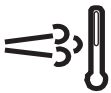

V1083542

HEST (High exhaust temperature) lamp, regeneration in progress

182 Operating instructions  
Exhaust aftertreatment system

**Cancelling parked regeneration**

**NOTE!**

Only cancel in an emergency.

- 1 Select "Stop" in the regeneration menu on the IC (Instrument Cluster).

An alarm indication on the instrument panel confirms that regeneration has been cancelled.

Regeneration is cancelled automatically when:

- a malfunction occurs
- machine operation starts and a parked regeneration is in progress
- the machine is turned off



V1135633







Regeneration cancelled

Alarms that require specific action			
Text on display panel	Display indication	Alarm level	Action
Park soon Parked regeneration needed	Warning, amber  V1128635	- buzzer sounds - amber central warning on	1 Park the machine in a non-heat-sensitive area. 2 Move the control lockout lever down to lock the system. 3 Start regeneration.  <b>NOTE!</b> Regeneration is cancelled if the control lockout lever is set to unlocked position or the engine is turned off. <b>NOTE!</b> The idle speed will be increased during the entire regeneration process.













Operating instructions  
Exhaust aftertreatment system 183

<p>Start regeneration Parked regeneration possible Press [SELECT] to start</p>	<p>Warning, amber</p>   <p>V1128635</p>	<ul style="list-style-type: none"> <li>- buzzer sounds</li> <li>- amber central warning on</li> </ul>	<ol style="list-style-type: none"> <li>1 Park the machine in a non-heat-sensitive area.</li> <li>2 Move the control lockout lever down to lock the system.</li> <li>3 Start regeneration.</li> </ol> <p><b>NOTE!</b> Regeneration is cancelled if the control lockout lever is set to unlocked position or the engine is turned off. <b>NOTE!</b> The idle speed will be increased during the entire regeneration process.</p>
<p>Keep machine parked Regeneration ongoing</p>	<p>Warning, amber</p>   <p>V1128635</p>	<ul style="list-style-type: none"> <li>- buzzer sounds</li> <li>- amber central warning on</li> </ul>	<ol style="list-style-type: none"> <li>1 Keep the machine parked.</li> </ol>
<p>Regeneration cancelled</p>	<p>Warning, amber</p>   <p>V1135633</p>	<ul style="list-style-type: none"> <li>- buzzer sounds</li> <li>- amber central warning on</li> </ul>	<ol style="list-style-type: none"> <li>1 Restart regeneration when possible.</li> </ol>







184 Operating instructions  
Exhaust aftertreatment system

<p>Park machine Parked regeneration required</p>	<p>Warning, amber</p>   <p>V1128635</p>	<ul style="list-style-type: none"> <li>- buzzer sounds</li> <li>- amber central warning on</li> </ul>	<ol style="list-style-type: none"> <li>1 Park the machine in a non-heat-sensitive area.</li> <li>2 Move the control lockout lever down to lock the system.</li> <li>3 Start regeneration.</li> </ol> <p><b>NOTE!</b> Regeneration is cancelled if the control lockout lever is set to unlocked position or the engine is turned off.</p> <p><b>NOTE!</b> The idle speed will be increased during the entire regeneration process.</p>
<p>Park safely Service regeneration needed</p>	<p>Warning, red</p>   <p>V1128638</p>	<ul style="list-style-type: none"> <li>- buzzer sounds</li> <li>- red central warning on</li> </ul>	<ol style="list-style-type: none"> <li>1 Park the machine in a non-heat-sensitive area.</li> <li>2 Move the control lockout lever down to lock the system.</li> <li>3 Turn off the engine.</li> <li>4 Contact a qualified service technician for regeneration.</li> </ol> <p><b>NOTE!</b> Regeneration is only possible using Volvo's service tool.</p>

Operating instructions  
Exhaust aftertreatment system 185

<p>Park machine Service needed Derate active</p>	<p>Warning, red</p>  <p>V1128638</p>	<ul style="list-style-type: none"> <li>- buzzer sounds</li> <li>- red central warning on</li> <li>- engine performance is significantly reduced</li> </ul>	<ol style="list-style-type: none"> <li>1 Park the machine in a non-heat-sensitive area.</li> <li>2 Move the control lockout lever down to lock the system.</li> <li>3 Turn off the engine.</li> <li>4 Contact a qualified service technician for replacement of the diesel particulate filter.</li> </ol> <p><b>NOTE!</b> The soot load can only be reset by qualified service technician.</p>
<p>Regeneration not needed</p>	<p>Information, blue</p>  <p>V1088268</p>	<ul style="list-style-type: none"> <li>- buzzer sounds</li> <li>- blue central warning on</li> </ul>	<ol style="list-style-type: none"> <li>1 No action required.</li> </ol>
<p>Continue operation Low temperature Regeneration pending</p>	<p>Warning, amber</p>  <p>V1128635</p>	<ul style="list-style-type: none"> <li>- buzzer sounds</li> <li>- amber central warning on</li> </ul>	<ol style="list-style-type: none"> <li>1 Continue operating the machine to warm up the exhaust aftertreatment system.</li> </ol>
<p>Service needed Regeneration not possible System failure</p>	<p>Warning, amber</p>  <p>V1203417</p>	<ul style="list-style-type: none"> <li>- buzzer sounds</li> <li>- amber central warning on</li> </ul>	<ol style="list-style-type: none"> <li>1 Service required.</li> <li>2 Contact a qualified service technician.</li> </ol>
<p>Lower CTRL lockout lever Regeneration needed</p>	<p>Warning, amber</p>  <p>V1128635</p>	<ul style="list-style-type: none"> <li>- buzzer sounds</li> <li>- amber central warning on</li> </ul>	<ol style="list-style-type: none"> <li>1 Park the machine in a non-heat-sensitive area.</li> <li>2 Move the control lockout lever down to lock the system.</li> <li>3 Start regeneration.</li> </ol>

Operating instructions  
**186 Exhaust aftertreatment system**

<p>Set engine speed as I2 Parked regeneration needed</p>	<p>Warning, amber</p>   <p>V1128635</p>	<ul style="list-style-type: none"> <li>- buzzer sounds</li> <li>- amber central warning on</li> </ul>	<ol style="list-style-type: none"> <li>1 Set the engine speed control switch as I2 mode.</li> <li>2 Park the machine in a non-heat-sensitive area.</li> <li>3 Move the control lockout lever down to lock the system.</li> <li>4 Start regeneration.</li> </ol>
<p>Park safely Only available when parked</p>	<p>Information, blue</p>   <p>V1088268</p>	<ul style="list-style-type: none"> <li>- buzzer sounds</li> <li>- blue central warning on</li> </ul>	<ol style="list-style-type: none"> <li>1 Park the machine in a non-heat-sensitive area.</li> <li>2 Move the control lockout lever down to lock the system.</li> <li>3 Start regeneration.</li> </ol>
<p>Arctic regen disabled</p>	<p>Information, blue</p>   <p>V1088268</p>	<ul style="list-style-type: none"> <li>- buzzer sounds</li> <li>- blue central warning on</li> </ul>	<ol style="list-style-type: none"> <li>1 Park the machine in a non-heat-sensitive area.</li> <li>2 Check that the arctic regeneration mode in IC (Instrument Cluster) menu is enabled.</li> </ol>



## Emission compliance

The aftertreatment system is monitored by diagnostic systems in the control units to ensure reduced emissions. If the system does not meet the emission requirements, it should not be possible to use the machine for work as usual. This takes place by a reduction of engine power (derate).

### Engine power is reduced if:

- The level in the AdBlue®/DEF tank is too low
- AdBlue®/DEF is of low quality
- There is a problem/malfunction with the aftertreatment system

There are two levels of engine power reduction (derate) that are activated after a certain time depending on the type of problem, as well as if the malfunction reoccurs or not.

### Restoring engine function

If the engine is restarted (by turning the ignition off and on) when engine power has been reduced, then full engine power (called restored engine function) can be obtained twice during derate level 1. This can be done in case of a danger or hazard and, e.g., if the machine has to be moved. This will not extend the time for activation of derate level 2.

188 Operating instructions  
Exhaust aftertreatment system

### Exhaust aftertreatment system, alarms requiring special actions

**NOTE!**

The display text will show "AdBlue®" in machines for the European market and "DEF" in machines for the US market.









AdBlue®/DEF level monitoring		
Display figure	Alarm level	Action
—	- solid symbol	1 Turn off the engine. 2 Fill AdBlue®/DEF in the AdBlue®/DEF tank.
Refill AdBlue  V1126376 AdBlue empty Derate active	- buzzer sounds 4 times - amber central warning on  V1205598 - flashing symbol - torque reduction	1 Turn off the engine. 2 Fill AdBlue®/DEF in the AdBlue®/DEF tank.
Park safely  V1126376 AdBlue empty Full derate soon	- buzzer sounds continuously - red central warning on  V1205599 - flashing symbol - torque reduction	1 Turn off the engine. 2 Fill AdBlue®/DEF in the AdBlue®/DEF tank.
Refill AdBlue  V1126376 AdBlue empty Full derate active	- buzzer sounds continuously - red central warning on  V1205599 - flashing symbol - forced idle or torque and speed reduction (depending on market)	1 Turn off the engine. 2 Fill AdBlue®/DEF in the AdBlue®/DEF tank.



Operating instructions  
Exhaust aftertreatment system

AdBlue®/DEF quality monitoring		
Display figure	Alarm level	Action
<p>Replace AdBlue</p> <p>Wrong AdBlue quality Derate soon</p>	<ul style="list-style-type: none"> <li>- buzzer sounds 4 times</li> <li>- amber central warning on</li> </ul> <ul style="list-style-type: none"> <li>- solid symbol</li> </ul>	<p>Contact a qualified service technician.</p>
<p>Replace AdBlue</p> <p>Wrong AdBlue quality Derate active</p>	<ul style="list-style-type: none"> <li>- buzzer sounds 4 times</li> <li>- amber central warning on</li> </ul> <ul style="list-style-type: none"> <li>- flashing symbol</li> <li>- torque reduction</li> </ul>	<p>Contact a qualified service technician.</p>
<p>Park safely</p> <p>Wrong AdBlue quality Full derate soon</p>	<ul style="list-style-type: none"> <li>- buzzer sounds continuously</li> <li>- red central warning on</li> </ul> <ul style="list-style-type: none"> <li>- flashing symbol</li> <li>- torque reduction</li> </ul>	<p>Contact a qualified service technician.</p>
<p>Replace AdBlue</p> <p>Wrong AdBlue quality Full derate active</p>	<ul style="list-style-type: none"> <li>- buzzer sounds continuously</li> <li>- red central warning on</li> </ul> <ul style="list-style-type: none"> <li>- flashing symbol</li> <li>- forced idle or torque and speed reduction (depending on market)</li> </ul>	<p>Contact a qualified service technician.</p>



190 Operating instructions  
Exhaust aftertreatment system





SCR-system failure monitoring		
Display figure	Alarm level	Action
Check SCR-system  SCR-system failure Derate soon	<ul style="list-style-type: none"> <li>- buzzer sounds 4 times</li> <li>- amber central warning on</li> </ul>  <ul style="list-style-type: none"> <li>- solid symbol</li> </ul>	Contact a qualified service technician.
Check SCR-system  SCR-system failure Derate active	<ul style="list-style-type: none"> <li>- buzzer sounds 4 times</li> <li>- amber central warning on</li> </ul>  <ul style="list-style-type: none"> <li>- flashing symbol</li> <li>- torque reduction</li> </ul>	Contact a qualified service technician.
Park safely  SCR-system failure Full derate soon	<ul style="list-style-type: none"> <li>- buzzer sounds continuously</li> <li>- red central warning on</li> </ul>  <ul style="list-style-type: none"> <li>- flashing symbol</li> <li>- torque reduction</li> </ul>	Contact a qualified service technician.
Check SCR-system  SCR-system failure Full derate active	<ul style="list-style-type: none"> <li>- buzzer sounds continuously</li> <li>- red central warning on</li> </ul>  <ul style="list-style-type: none"> <li>- flashing symbol</li> <li>- forced idle or torque and speed reduction (depending on market)</li> </ul>	Contact a qualified service technician.

DPF-system failure monitoring		
Display figure	Alarm level	Action
Check DPF-system  DPF-system deactivated	<ul style="list-style-type: none"> <li>- buzzer sounds 4 times</li> <li>- amber central warning on</li> </ul>  <ul style="list-style-type: none"> <li>- solid symbol</li> </ul>	Contact a qualified service technician.





Operating instructions  
Exhaust aftertreatment system 191

<p>Check DPF-system</p>  <p>V1201756</p> <p>DPF-system missing</p>	<ul style="list-style-type: none"> <li>- buzzer sounds 4 times</li> <li>- amber central warning on</li> </ul>  <p>V1205598</p> <ul style="list-style-type: none"> <li>- solid symbol</li> </ul>	<p>Contact a qualified service technician.</p>
<p>Check DPF-system</p>  <p>V1201756</p> <p>DPF-system failure</p>	<ul style="list-style-type: none"> <li>- buzzer sounds 4 times</li> <li>- amber central warning on</li> </ul>  <p>V1205598</p> <ul style="list-style-type: none"> <li>- solid symbol</li> </ul>	<p>Contact a qualified service technician.</p>



## Stopping

- 1 Select as level ground as possible to park the machine.
- 2 Lower the attachment to the ground.
- 3 Leave the engine running at low idling speed for approx. 2 minutes before shutting off the engine. Otherwise the lubrication of the turbocharger may be jeopardised, resulting in shorter service life and great risk of bearing seizure.
- 4 Turn the ignition switch to stop position.
- 5 Move the control lockout lever down to lock the hydraulic system securely.
- 6 If the machine is to be left for any length of time, the battery disconnect switch should be turned off.

Keep in mind that the theft and burglary risk can be minimised by:

- Removing the ignition switch when the machine is left unattended.
- Locking doors and covers after working hours.
- Turning off the current with the battery disconnect switch.
- Parking the machine where the risk of theft, burglary and damage is minimised.
- Removing all valuables from the cab such as cellular phone, computer, radio and bags.
- Chaining the machine.

By etching in the PIN-number or the national licence plate number of the machine on its windows, it is easier to identify stolen machines.

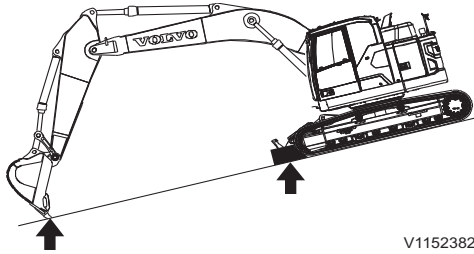

V1152382

## Parking

### NOTICE

Choose level ground for parking the machine. If the machine has to be parked on an incline, the tracks must be blocked with wooden blocks and the bucket teeth pressed into the ground.

- 1 Park the machine with proper condition that the piston rods of the attachments will be protected against moisture, dust and damage.
- 2 Follow the paragraphs 3 - 6 above of "Stopping".
- 3 Make sure that there is enough anti-freeze in the cooling system (see page 307) and in the washer fluid at temperatures below 0 °C (32 °F) when the machine is parked.
- 4 Make sure that the AdBlue®/DEF tank is completely filled.
- 5 The temperature may not be below -40 °C (-40 °F) or above +40 °C (104 °F) if the machine will be parked for up to two months.
- 6 Close and lock all windows, doors and all covers.

### Long-term parking (parking for longer time than two months)

Follow the instructions as for parking and in addition to that:

- 1 The temperature may not be below -40 °C (-40 °F) or above +25 °C (77 °F).
- 2 Wash the machine and touch up the paint finish to avoid rusting.
- 3 Check the machine for leakage of oil or water, and defects of the attachments and the tracks. Replace or repair all damaged or worn parts.
- 4 Treat exposed parts with anti-rust agent, lubricate the machine thoroughly and apply grease to unpainted surfaces like cylinders.
- 5 Fill the fuel tank and the hydraulic oil tank to the maximum marks.
- 6 Make sure that the freezing point of the coolant is sufficiently low (in cold weather).
- 7 Place the machine on level, firm ground where there is no risk of freezing, landslide or flooding.
- 8 When storing machines in extreme cold temperatures, remove batteries and store them at room temperature. Make sure to place the batteries over a wooden/plastic/rubber surface.



- 9 Cover the exhaust pipe (for parking out-of-doors).

**NOTICE**

Start the engine once a month and run it at low idling speed for one hour. Operate all function cycles when working temperature has been reached.

**Check after long-term parking**

- All oil and fluid levels
- Tension of all belts
- Air cleaner
- Batteries
- Lubricate all greasing points
- Wipe off grease from piston rods
- Hydraulic hoses
- Seals
- That the AdBlue®/DEF pump unit filter is replaced if the machine is parked for longer than four months. Contact a qualified service technician.

**NOTE!**

If a preservative has been used on the machine to prepare it for long term storage, follow the manufacturer's instructions for any necessary safety precautions and the method of removal.

## Retrieving and towing

### WARNING

Risk of personal injury.

Faulty or improper lifting equipment could cause the machine to break away from the lifting vehicle, causing accidents, serious injury or death.

**Use certified cables, lifting straps, slings, shackles and hooks with adequate load capacity and never lift the machine with a person in or on the machine.**

### WARNING

Risk of runaway machine.

Improper towing methods or faulty equipment could cause the machine to break away from the towing vehicle, causing accidents, serious injury or death.

**Carefully follow the towing instructions and use only certified towing equipment with adequate load rating.**

### NOTE!

Only use the rear-mounted towing hook and the attaching point for a towing bar for towing the machine.

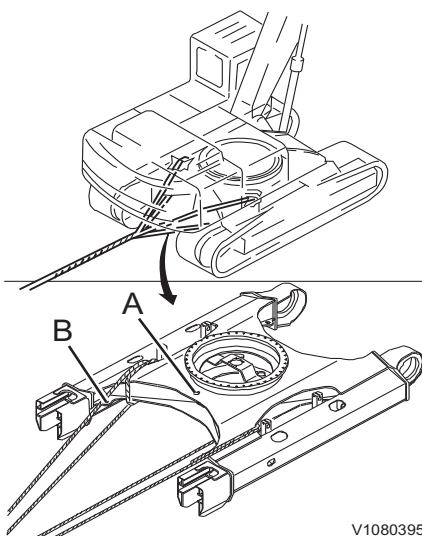

V1080395

Retrieval device is used when the machine is in the event of slipping into swampy ground or being disabled.

- 1 Attach a wire rope to be retrieved or to tow the machine as shown in the illustration. Ensure that the towing linkage is properly connected, adequate for the purposes.
- 2 Towing speed for short distance is maximum 2 km/h and use other transportations for long distance.
- 3 Keep the tow line angle as small as possible
- 4 Angle for pulling should not exceed 20° from the horizontal line of tow lope and longitudinal axis of the machine. Be careful there should not be also interference with parts of the machine.

There is a hole (A) on the lower frame to fit the shackle only for towing light objects.

- 1 The shackle must be used for the hole (A).
- 2 Permissible forces of the hole (A) for towing is as follows.

196 Operating instructions  
Retrieving and towing

■ 13,900 kg (30,643 lb)

**NOTE!**

Do not use shackle holes (B) to retrieve or tow the machine. These holes are only for anchoring when transporting the machine, see page 199.

**Manual release of travel brake**

If it is impossible to operate the machine due to the failure of the components in the track motor, the travel brake should be released. Contact a qualified service technician for detailed information.

- 1 Apply constant hydraulic pressure of 3.9 MPa (40 kgf cm<sup>2</sup>, 569 psi) at port (A) of the track motor using external pressure source to keep the brake released.
- 2 Connect a hydraulic hose between port (B) and port (C) after removing plugs to move the machine.

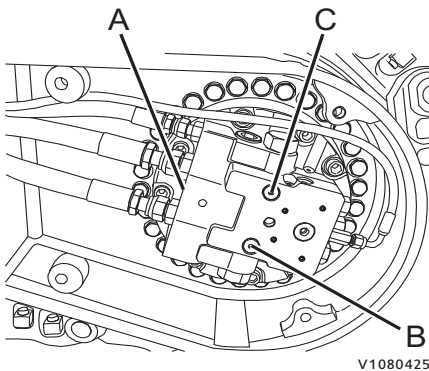

V1080425

- A Brake released port
- B Pressure gauge port
- C Pressure gauge port

## Transporting machine

### Measurements before transporting machine

#### **NOTICE**

The person in charge of the transport must see to that loading, positioning, lashing and transporting the machine on a trailer or other vehicle is done according to applicable laws and regulations for the country or state in question. For further information, contact your dealer.

#### **NOTICE**

If vandal protection is installed on the machine, it should be removed before the machine is transported. Check local or national regulations.

### Total and disassembled specifications, weight and dimension

Weight and dimension are very useful to estimate the method how the disassembled parts are supposed to be transported. To comply with the laws and regulations in certain region, use the specifications of total and disassembled parts. See pages 370, 364 and 373.

### Sunlight protection, closing

The sunlight protection may be opened while transporting the machine because of vibration. Therefore it should be closed tightly not to be opened.

198 Operating instructions  
Transporting machine

**Satellite antenna, folding (optional equipment)**

When transporting the machine or using the machine in an area limited the height, the satellite antenna can be damaged.

Fold satellite antenna (A) using spring (B) like the figure. In this case, it may be limited for satellite communication of the machine.

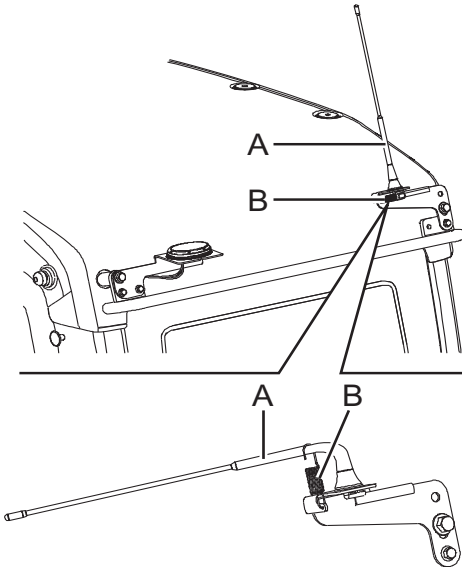

V1099532

A Satellite antenna  
B Spring

**Halogen beacon lamp, folding (optional equipment)**

When transporting the machine, fold bracket (B) with rotating beacon lamp (A) not to be damaged.

- 1 Loosen screw (C) and then turn down rotating beacon lamp (A).
- 2 Fasten the screw (C).

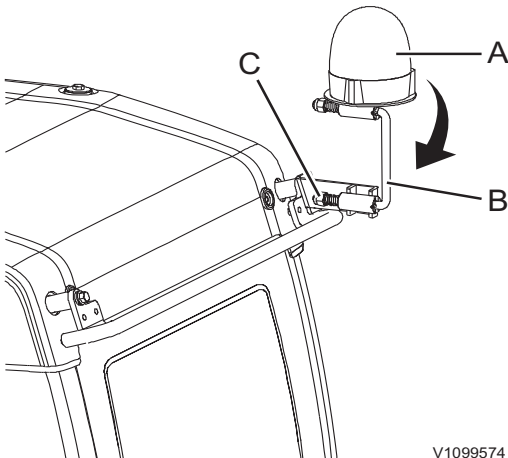

V1099574

**LED rotating beacon, disassembling (optional equipment)**

When transporting the machine, disassemble rotating beacon (A) not to be damaged.

- 1 Loosen wing screw (B) and disassemble rotating beacon (A).
- 2 Keep rotating beacon (A) in the cab during transportation.
- 3 Put rubber cover (D) on bracket (C).

**NOTE!**

If you remove the rotating beacon, be sure to put the rubber protection on the fixing tube. This will avoid rust and other possible damages.

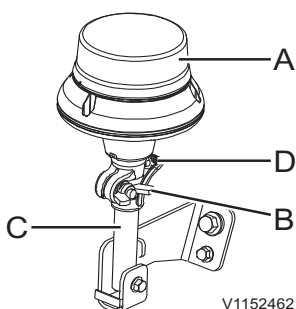

V1152462



## Tying down machine

### **WARNING**

Risk of crushing.

Material may fall off when loading a vehicle.

**Make sure that no persons are standing near the vehicle while loading.**

### **NOTE!**

Make sure that loading ramps and platforms are free from oil, mud, ice and similar so that the machine does not begin to slip.

### **NOTICE**

The function for automatic idling must be deactivated with the button on the keyboard in order to avoid that the speed increases during loading and unloading of the machine.

### **NOTICE**

Select low engine speed and low travelling speed for loading and unloading the machine.

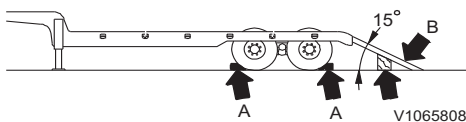

- 1 Place the trailer on a firm and level ground.
- 2 Apply the brake of the trailer.
- 3 Insert blocks (A) in front of and behind the tyres of trailer.
- 4 Fix loading ramps (B) securely.
  - Make sure that the strength, width, length and thickness of the planks are safe for loading.
  - Make sure that the angle of loading ramp is 15° or less.
- 5 Check whether the right and the left loading ramps are of the same height.

## 200 Operating instructions Transporting machine

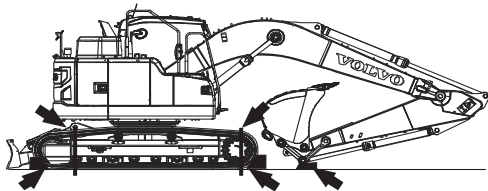
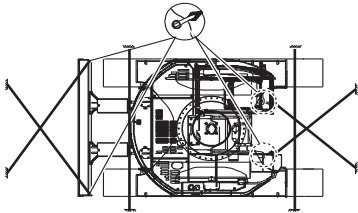
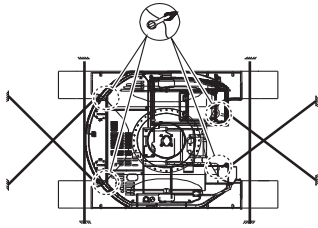

V1151774

- 6 Decide the direction and travel slowly onto the loading ramps and trailer bed / platform. Block each track and secure the machine with tie downs of adequate load rating so that the machine cannot move.
  - Load the machine so that the bucket cylinder rod does not contact the trailer.
  - Never operate any lever other than the travel levers (pedals) while the machine is on the loading ramp.

### **NOTICE**

**Do not extend dipper arm or bucket cylinders to their end positions as they then run the risk of being damaged.**

- 7 Stop the machine.
- 8 When some parts of machine are disassembled, load the disassembled components on the trailers properly. If necessary, put the blocks behind or below the components.
- 9 Remove the ignition switch.
- 10 Turn OFF the battery disconnect switch.
- 11 Lock the door and the access covers.
- 12 Cover the exhaust pipe to prevent turbocharger from damage.
- 13 Ensure that the machine or disassembled components are firmly secured.

## Lifting machine

### WARNING

Risk of personal injury.

Faulty or improper lifting equipment could cause the machine to break away from the lifting vehicle, causing accidents, serious injury or death.

**Use certified cables, lifting straps, slings, shackles and hooks with adequate load capacity and never lift the machine with a person in or on the machine.**

### WARNING

Risk of crushing.

Falling load could cause serious injury.

**Do not stand under a suspended load. Use appropriate loading and lifting equipment.**

### NOTE!

Incorrect or faulty equipment or improper lifting methods may cause accidents. Therefore, carefully follow the instructions given below.

Lift the machine on flat, even and level ground.

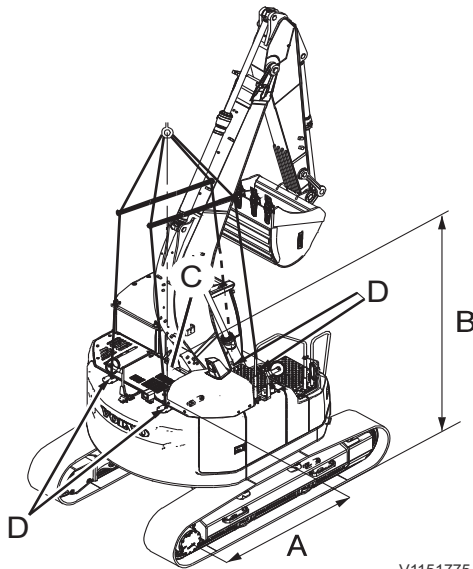

- A 1672 mm (66 inches)
- B 1346 mm (53 inches)
- C Center mark for the center of gravity
- D Lifting points

- 1 Start the engine, and arrange the bucket, dipper arm and boom as illustrated. Position the superstructure boom forward over the idlers.
- 2 Move the control lockout lever down to lock the system securely, see page 111.
- 3 Stop the engine, check the safety around the machine.
- 4 Close and lock the windshield, cab door and engine hood securely.
- 5 As shown in the decal for lifting, connect lifting cables or slings with sufficient strength for the machine weight at the lifting points correctly.
- 6 After installation of all hoisting equipment, lift the machine a little to check its balance, if satisfactory, lift it slowly and evenly.
- 7 Maintain good visibility of the machine at all times during the lift. And continuously check that the machine is level.



## Operating techniques

The excavator is a multi-task machine capable of being fitted with multitude special attachments to perform many types of work. This chapter contains information and instructions regarding the best operating practices to improve efficiency, including examples on how the most common attachments are used. It is important that the correct technique is used to obtain safe and efficient use of the machine.



## Whole-body vibrations

Whole-body vibration emission on construction machinery are affected by a number of factors, such as working mode, ground conditions, speed, and so on.

To a large extent the operator can influence the actual vibration levels, because the operator controls the speed of the machine, its working mode, the travel path, and so on.

Therefore, the result can be a range of different vibration levels for the same type of machine. For cab specifications, see page 360.

### Guidelines for reducing vibration levels on earthmoving machines

- Use the proper type and size of machine, with optional equipment and attachments for the application.
- Keep the terrain and haul roads in good condition.
  - Remove any large rocks or obstacles.
  - Fill any ditches and holes.
  - Provide equipment and schedule time to maintain terrain conditions.
- Adjust the speed and travel path to minimize the vibration level.
  - Drive around obstacles and rough terrain conditions.
  - Reduce the speed when it is necessary to go over rough terrain.
- Maintain machines according to the manufacturer's recommendations.
  - Track tensions. (crawler machine only)
  - Tire pressures. (wheel machine only)
  - Brake and steering systems. (wheel machine only)
  - Controls, hydraulic system and linkages.
- Keep the seat maintained and adjusted.
  - Adjust the seat and its suspension according to the weight and size of the operator.
  - Inspect and maintain the seat suspension and adjustment mechanisms.
  - Use the seat belt and adjust it correctly.



## 204 Operating techniques Whole-body vibrations

---

- Steer, brake, accelerate, shift gears, and move the attachments smoothly. (wheel machine only)
- Minimize vibrations for long work cycle or long distance travelling.
  - Use suspension systems if available.
  - If no suspension system is available, reduce speed to prevent bouncing.
  - Transport machines when there are long distances between worksites.

Back pain associated with whole-body vibrations may be caused by other risk factors.

The following guidelines can be effective to minimize risks of back pains:

- Adjust the seat and controls to achieve good posture.
- Adjust the mirrors to minimize twisted posture.
- Provide breaks to reduce long periods of sitting.
- Avoid jumping down from the machine.
- Minimize repeated handling and lifting of loads.
- Maintain reasonable weight and physical condition.

## Rules for digging

### **WARNING**

Risk of serious injury.

More than one person in the cab while operating could cause accidents and serious injury.

**Only the operator, seated in the operator's seat, may be in the cab when operating. All other persons must keep at a safe distance from the machine.**

First read the safety rules for operating, see pages 166, 167, 168, and 170.

- Always prepare work by carefully studying drawings and regulations that apply to the site. Also study the ground conditions and what the risk areas on the site look like. Turn off gas, electricity and water supplies, if this is necessary. Mark the position of cables and pipes.
- Fence off the area around the machine, if there is a risk that people may get too close. Pay attention to a swinging machine.
- Look after your workmates! Make sure that they take care. No persons, apart from the operator, may be present within the working area of the machine. Teach them to be on their guard against collapsing banks and rolling stones and to be prepared to dash for safety. Changes in stress in a bank immediately prior to a landslide are indicated by small streams of loose material just where the cracks are forming.
- If the machine is provided with optional equipment, which is operated with the pedals, the operator must assure him or her self of that the anticipated movements are obtained when actuating the pedals. An unexpected movement may entail risk of an accident.
- A cab provided with protective grill over the roof window meets the requirements for falling object guard in accordance with stated testing methods (FOPS/ISO 10262). Use the falling object guard when there is risk of heavy, falling objects.

## NOTICE

With certain attachment combinations there is a risk that the attachment may strike the cab. Avoid damage by being careful when working close to the machine.

- Never swing the bucket or load above people.
- Never use the bucket for chopping.
- If uncontrolled movements should occur, first release levers and pedals, then shut off the engine immediately by turning the ignition switch to the stop position.
- If red warning lamps light up and/or the buzzer is sounding, the engine must be stopped immediately and the cause investigated.
- The machine must not be equipped with a larger bucket/attachment than permitted.
- When using equipment which generate knocks or vibrations, for example hammer, the hydraulic cylinders must not be operated closer than 10 cm (4 in) from their end-of -stroke positions.
- In case of fire, the battery disconnect switch should be turned off, if possible. See page 264.

## Loading on to a vehicle

### WARNING

Risk of crushing.

Material may fall off when loading a vehicle.

**Make sure that no persons are standing near the vehicle while loading.**

- If possible, position the machine higher than the vehicle to be loaded.
- Place the vehicle to be loaded so that the machine does not have to swing and lift more than necessary.
- Make sure that the driver of the vehicle to be loaded stays outside the working area of the machine and never swing the bucket over the cab of the vehicle to be loaded.
- Do not load the vehicle unevenly and avoid unnecessary spillage when loading. Do not make the load so high that earth and stones fall over the platform sides.
- Release the load carefully.





**When working, do not:**

- use the swing force for raking over the ground, demolition of buildings or thrusting bucket teeth into the ground. It may cause damage to the machine and attachments.
- dig by using the travelling motors or thrusting bucket teeth into the ground. This can overload the rear of the machine and damage the track drive.
- extend the hydraulic cylinder to its end of stroke. This can overload the stop in the cylinder and shorten the life span of the machine. Work with as much clearance as possible.
- work by slamming the bucket into the ground. Do not perform digging by dropping the boom, or using the bucket instead of a pick. Striking digging or continuous striking can overload the rear of the machine or damage the attachment. It is also very dangerous.
- carry out lifting work. Basically, using this machine as a crane is prohibited. However, local or national regulations may allow it on some markets. If permitted, a properly installed rated bucked hook and certified slings / shackles are required. Contact a workshop authorised by Volvo Construction equipment.
- operate by dropping the machine body.

## Working within dangerous areas

- Observe great care at marked danger areas.
- Do not operate too close to the edge of a quay, ramp, ditch and so on.
- Move slowly when working in confined spaces and check that there is sufficient room for machine and load.
- When working under ground, special equipment, for example certified engine is required within the EU and in EES countries. Talk to your dealer.
- When working in low light conditions, for example buildings and tunnels, use head light.
- Do not operate the machine when visibility is poor such as a heavy fog, snow or rain.
- When working in an area which is contaminated or dangerous to one's health, the machine must be especially equipped for this purpose. Talk to your dealer. Check also local regulations before entering the area.

## High voltage overhead power line

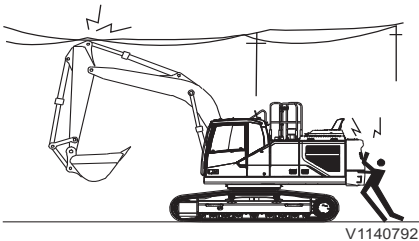

**! DANGER**

Risk of electrocution  
Working near or making contact with overhead power lines may lead to electrical flashover and electrocution.

**Always keep the minimum clearance from overhead power lines.**

**! DANGER**

Risk of electrocution.  
Contact with live parts will cause death or serious injury.

**Never touch live electrical parts.**

Operating techniques  
**Working within dangerous areas** 209

High voltage is lethal and the current sufficiently strong to destroy both machine and attachments. Your life is in danger if you come into contact with or close to high voltage power lines. Always contact the power company responsible before beginning any work near high voltage power lines. Go through the special instructions issued by the power company for work/presence near the power lines. Regard all power lines as if they were live even if they are supposed to be without current. Working when the machine or its load at any time is closer than the minimum safety distance to a power line, is taking a very serious risk.

- Remember that the voltage of the power line determines the safety distance. Electrical flash-over may occur and damage machine and operator at fairly great distances from the power line.

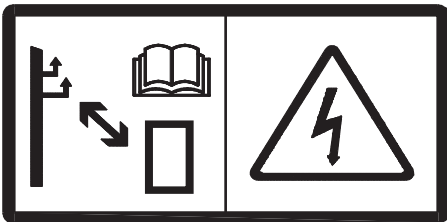

V1079478

Voltage	Minimum distance to power line
0 ~ 50 kV	3 m (10 ft)
50 ~ 69 kV	4.6 m (15 ft)
69 ~ 138 kV	5 m (16.4 ft)
138 ~ 250 kV	6 m (20 ft)
250 ~ 500 kV	8 m (26 ft)
500 ~ 550 kV	11 m (35 ft)
550 ~ 750 kV	13 m (43 ft)
750 kV~	14 m (46 ft)

**NOTICE**

The operator should have secure visibility when working around the power lines.

**NOTICE**

When transporting the machine also take overhead power lines into consideration.



## 210 Operating techniques Working within dangerous areas

---

### **NOTICE**

**Remember that the roof window may distort how distance is perceived.**

- Keep the following in mind to ensure safety when operating.
  - Operate the machine slower than normal operation in the vicinity of power lines.
  - Consider the long-span power line, which can sway and reduce the clearance.
  - Pay attention when travelling over uneven ground that could cause the machine to lose balance.
  - Keep all persons away from the machine whenever it is close to power lines.
  - Prohibit persons from touching the machine or its load before it is confirmed to be safe.
- Find out what action to take if a person has been exposed to an electric shock.
- Procedure if a machine touches the power line.
  - The operator should stay inside the cab.
  - All other persons should keep away from the machine, ropes, and load.
  - The operator should try to remove the machine from contact by moving it in the reverse direction from that which caused the contact.
  - If the machine cannot be moved away from contact, the operator should remain inside cab until the lines have been de-energized.



## Operating techniques Working within dangerous areas 211

---

### Overhead railway power lines



Risk of electrocution

Working near or making contact with overhead power lines may lead to electrical flashover and electrocution.

**Always keep the minimum clearance from overhead power lines.**



Risk of electrocution.

Contact with live parts will cause death or serious injury.

**Never touch live electrical parts.**

Loading and unloading is only permissible between the boundary signs. The signs may be mounted directly on the power line or on special posts.

- Contact authorised railway personnel to obtain permission to load or unload.
- After any breaks in the work, always contact the railway personnel again.



## 212 Operating techniques Working within dangerous areas

---

### Underground cables and pipes

Make sure that authorities or companies responsible for cables and pipes have been contacted and that their instructions are followed. Also check which rules apply to ground personnel regarding exposing cables and pipes. Normally only the service companies' own personnel may expose and arrange provisional suspension of cables. Make use of a signal man when you cannot see the actual point where you are working or when the position of the pipe or cable is critical, see page 256. The position of the pipe or cable may deviate from the drawing or distances may be incorrectly determined. Regard all electrical cables as live.

## Working on slopes

### NOTICE

In order not to jeopardise the lubrication of the engine, the machine must not be inclined more than 35 degrees in either direction. In addition it may be unsuitable to operate at this inclination as the machine may become unstable and unbalanced, depending on the load.

### Caution on a slope

- Be careful when opening or closing the doors on a slope, operational force may be changed rapidly. Make sure to keep the doors closed.
- Do not descend backward on a slope.
- Operate the travel function slowly when approaching or descending a slope.
- Do not change direction or travel a cross on a slope. Change direction on level ground, if necessary first come down to level ground and make a detour.
- If the machine slides, immediately lower the bucket to the ground. The machine can turn over due to unbalance. Especially, do not swing with loaded bucket. In unavoidable case, pile up earth on the slope, and then make the machine level and stable.
- While travelling on a slope, keep the angle between boom and dipper arm at 90 - 110 °, raise the bucket 20 - 30 cm from the ground
- While travelling down on a slope, keep the angle between boom and dipper arm at 90 - 110 °, raise the bucket 20 - 30 cm from the ground and travel at low speed.

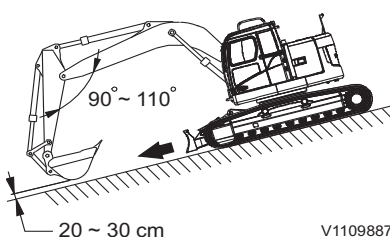
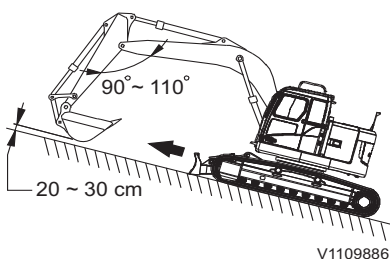
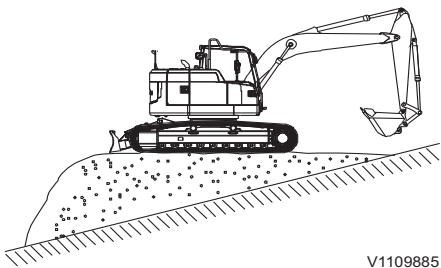
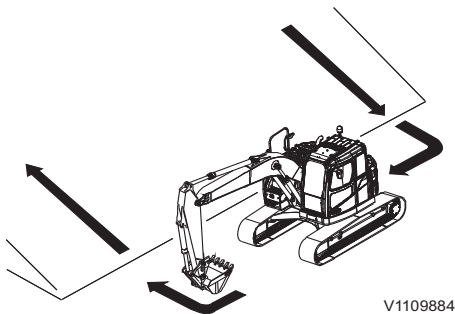

## 214 Operating techniques Working within dangerous areas

### In case of shoes slipping

If the shoes slip on a slope, thrust bucket into the ground, and pull the dipper arm in to assist the track drive to move the machine up the slope.

### In case of engine failure

In case of engine shut down while travelling on a slope, put the travel lever to neutral position and lower bucket down to the ground, then start the engine.

If the engine shuts down on a slope, do not operate the swing function, since the superstructure may be swung under its own weight and cause tipping or side slipping.

### Travelling on uneven ground

- In case of travelling on uneven ground, reduce travel speed and operate the machine so as not to lean to one side more than 10°.

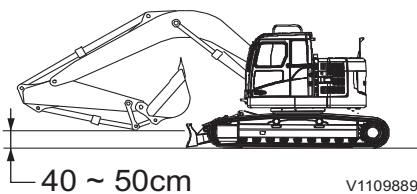
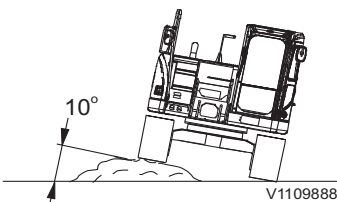

- In case of travelling on flat ground, retract the attachment and raise it 40 - 50 cm from the ground.



## Operating techniques Working within dangerous areas 215

### Working in water and on boggy ground

Be very careful when working on boggy ground.

#### In case that one track gets bogged

If one track gets bogged down, raise this track using the bucket and put a plank under the track.

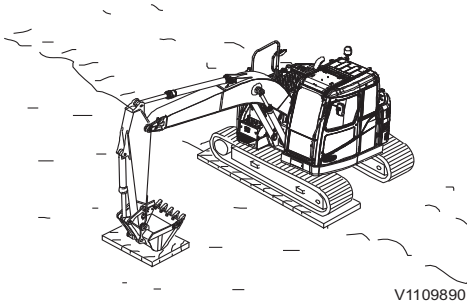

V1109890

#### **NOTICE**

When the machine is lifted with the aid of the boom or the dipper arm, the bottom of the bucket should rest on the ground not the bucket teeth.

Set the angle between boom and dipper arm at  $90^\circ \sim 110^\circ$ .

After working in water or escaping from boggy ground, replenish the grease to the attachment pins or the areas affected by the water. Check the idler, rollers and track drive case oil, if contaminated, change the oil.

#### In case both tracks get bogged

In case that both tracks get bogged down, put planks under each track. Thrust the bucket into the ground, pull with the dipper arm as when digging, and move the travel lever forward to escape.

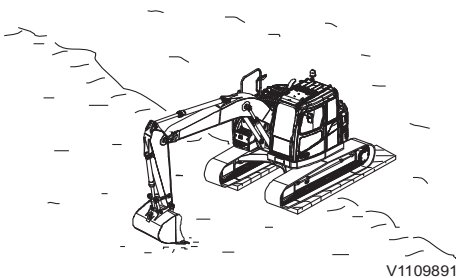

V1109891

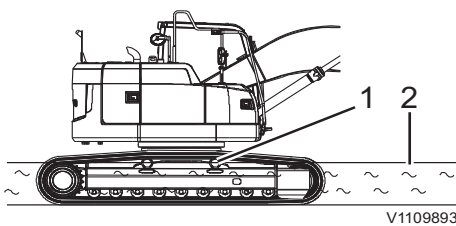

V1109893

- 1 Top roller
- 2 Water level

#### Permissible depth of water

#### **NOTICE**

Pay attention to the permissible water depth in order to avoid damage to the machine.

Permissible working depth in water is the center of top rollers.

Do not fully submerge the top rollers.

Upon leaving the water, make sure all the grease is replenished in the areas affected by the water, for example bucket pin and so on, remove the old grease completely regardless of the maintenance period. Also check the oil in the travel drive for contamination, and if necessary, replace it.

## Working in cold weather

### DANGER

Risk of electrical shock.

Personal injury results if a body part comes into contact with a machine that conducts electric power.

**Disconnect the electrical engine heater before working on the machine.**

### WARNING

Risk of frostbite.

Bare skin can freeze stuck to cold metal which could cause injury.

**Use personal protective equipment when handling cold objects.**

### WARNING

Risk of crushing injury.

The hydraulic system could respond slowly at low temperatures and could cause unexpected machine movements.

**Operate carefully until the hydraulic system has reached operating temperature.**

Read the advice for starting, see page 172.

Use appropriate fluids for the ambient working temperatures. (see recommended fluids in specification section.)

The windows must be free from ice and snow before putting the machine to work.

- Watch out for ice on the machine causing slippery conditions. Step only onto anti-slip surfaces.
- Use an ice scraper on a long handle or a ladder when removing ice from the windows.

## Operating techniques

# Working within dangerous areas 217

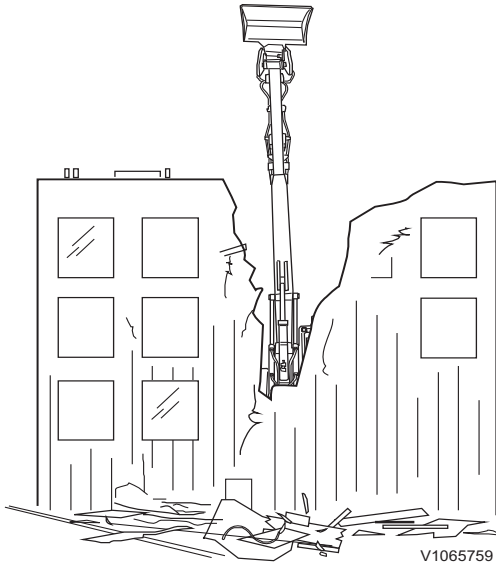

V1065759

### Demolition work

The machine is often used for demolition work. Be extremely careful and study the work site thoroughly. Use fall protection over the cab against falling objects.

- Make sure that the material, on which the machine is standing, cannot collapse or slide.
- Operate the machine on firm level ground, if necessary prepare the area with another machine first.
- Do not work close to free-standing walls, which may fall over the machine.
- At all times be aware of where your workmates are. Do not work if anyone is dangerously close to the demolition object.
- Leave sufficient space in front of the machine for debris to fall to the ground and not hit the cab.
- Fence off the dangerous part of the work site.
- Spray water over the demolition site to prevent harmful dust from spreading.

Boots with steel reinforcements in the soles and toe caps, protective goggles and a hard hat are obvious protective items to be worn on a demolition site.

If the machine is equipped with special demolition equipment, read the supplied instruction booklet about the safety risks that might occur and how the demolition equipment is used.

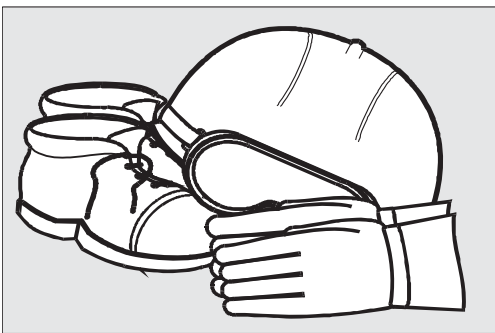

V1067189

## 218 Operating techniques Working within dangerous areas

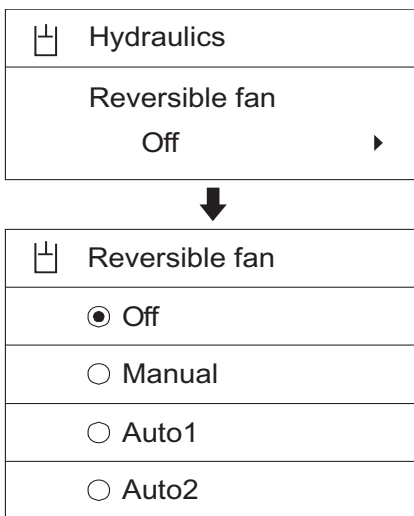

V1137864



V1068779

### Reversible fan

#### (Optional equipment)

The reversible fan is designed to clean the cooling module (clogging net, radiator and oil cooler fins), maintain the cooling performance and also extend the cleaning interval.

#### Modes and setting

The reversible fan is set up by the IC (Instrument Cluster) menu as one of "Off", "Manual", "Auto1", "Auto2" mode. It also allows the operator to select a reversible fan mode. The "Off" mode is set up as default initially.

- **Off mode:** Maintain normal rotation or revert to "Off" mode by stopping reverse rotation. Also selecting the "Off" mode during the "Manual" mode cancels the reverse rotation and returns to previous setting mode.
- **Manual mode:** Reverses the rotation one cycle immediately after setting the mode. After finishing the "Manual" mode, returns to the previous setting mode. Reverse rotation time is set up as 60 seconds and changeable between 20 to 180 seconds by Volvo's service tool. Contact a workshop authorized by Volvo.
- **Auto1 mode:** Repeats a cycle consisting of normal rotation and reverse rotation. Normal rotation time is set up as 60 minutes and changeable between 20 to 120 minutes by Volvo's service tool. Contact a workshop authorized by Volvo. Reverse rotation time is set up as 20 seconds and not changeable.
- **Auto2 mode:** Repeats a cycle consisting of normal rotation and reverse rotation. Normal rotation time is set up as 20 minutes and not changeable. Reverse rotation time is set up as 20 seconds and not changeable.

#### NOTE!

The reversible fan indicator is shown on the indicator screen of IC (Instrument Cluster) during reverse rotation.

## Attachments

### Boom float position, description

Float position means that both the boom cylinders' piston and piston rod sides are connected to the hydraulic tank. The boom then floats with the weight of the attachments when operating the boom lever forward. The boom lifting is not affected by float position.

Float position gives better fuel economy, faster excavation cycle, less wear and less vibration. When the float position is engaged, the hydraulic oil of the machine can be used for other purposes than lowering the boom, such as the dipper arm and/or bucket operation. These functions then become faster and more efficient.

#### Keep the following in mind.

- Always make sure that the boom operating lever is in the neutral position before activating the float position.
- Do not select the float position mode while the track or tracks are elevated. Selecting the float position mode and operating the boom operating lever forward (boom down position) while the track or tracks are elevated could cause the machine to drop down suddenly.
- Do not release float position mode while the boom operating lever forward (boom down position) and bucket or tool is on the ground. This could cause the machine to tilt up suddenly.
- Do not attempt to lift the track or tracks while the machine is in float position mode.



V1065876

## 220 Operating techniques Attachments

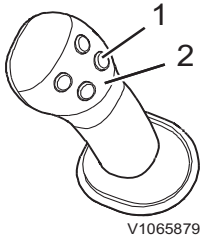

V1065879

- 1 Float On / Off button
- 2 Control lever with four buttons



V1065880

Indicator on the instrument panel

Use the float position when the attachment has to follow the irregular ground, such as for bedrock clearance, grapple handling and when unloading barges and flatbeds. Float position also makes unloading more manageable.

- 1 Select the float position using button 1 on the right control lever in order to activate the float function. The control lever should have the float function, see page 96. The float operation indicator on the front instrument panel lights up.
- 2 Float position is only in operation when you push the boom operating lever forward. When the attachment is to follow the ground, the boom operating lever must therefore be held forwards all the time. The boom can then move upward and downward freely depending on the state of the ground.
- 3 Deactivate the float position by pressing the button 1 again. The indicator on the instrument panel will go out.

### NOTE!

When the boom float function is on, the function will remain even if the ignition switch is off and on again. The indicator on the instrument panel will be also displayed.

## Attachments, connecting and disconnecting

### Attachment quick coupler

S type quick coupler, S1 (optional equipment)

#### WARNING

Risk of crushing.

Falling attachments could result in severe injury or death.

**Make sure the attachment bracket is properly locked before starting work.**

#### WARNING

Risk of crushing.

An unsecured attachment could fall and cause serious injury or death.

**Always ensure the attachment is properly secured by pressing the front part of the attachment to the ground until the machine is slightly lifted.**

The attachment quick coupler consists of flat mounting plates which are attached to the end of dipper arm and bucket link. There are two hooks (F) on the plate for the pins (B) on the bucket.

There is a lift hook (C) on the attachment quick coupler.

The attachment quick coupler is equipped with a double-acting hydraulic cylinder. The quick coupler's lock wedge (D) is fitted to its piston rod. Servo pressure acts on the piston of the lock cylinder, locking the bucket in place against rear hook (E). This means that the lock wedge adjusts itself and provides gap-free locking.

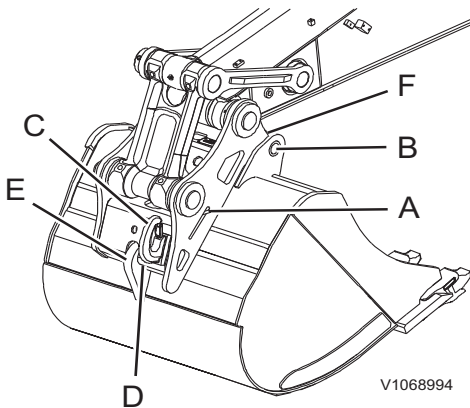

- A Red indicator pin
- B Bucket pins
- C Lift hook
- D Lock wedge
- E Bucket rear hook
- F Hooks for gripping attachment

## 222 Operating techniques Attachments, connecting and disconnecting

When the lock wedge (D) is released, the servo pressure is transferred to the piston rod side. If necessary, the release pressure can be increased by loading the bucket cylinder in its end position.

There is a red indicator pin (A) on the left side of the quick coupler, which is pulled in when the lock wedge is in the locked position and pushed out when the lock wedge is released.

With the lift hook, the machine can be used for lifting operations. Since the hook is located on the attachment quick coupler, it can be used without bucket. This improves visibility for the operator and increases the maximum permissible load.

### NOTE!

See page 250 for information on lifting objects.

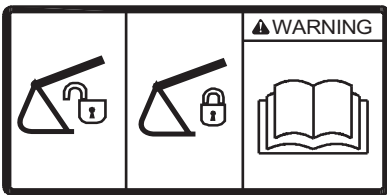

V1065833

### WARNING

The attachment quick coupler may be open regardless of what is indicated by the alarm signal or on the instrument panel. Therefore, always check that the attachment quick coupler is locked securely. Also read the instructions in the operator's manual.

### WARNING

Risk of crushing.

If the pressure in the attachment quick coupler cylinder drops, the attachment could fall off and cause serious crushing injury or death.

**Never install shut-off valves in the lines leading to the cylinder for the attachment quick coupler.**



## Bucket, removing

### WARNING

Risk of crushing!

Attachments that move unexpectedly can cause injuries.

**Make sure people stay out of the working area when connecting or disconnecting attachments.**

- 1 Position the machine on even, firm and level ground with the bucket resting on the ground.
- 2 Press down to release the red lock device (A) on the right attachment quick coupler switch and then press the switch to position (1) to initiate the attachment quick coupler.

When the attachment quick coupler is initiated, the buzzer sounds and the check message and indicator are displayed on the IC (Instrument Cluster). See page 80 for more information.

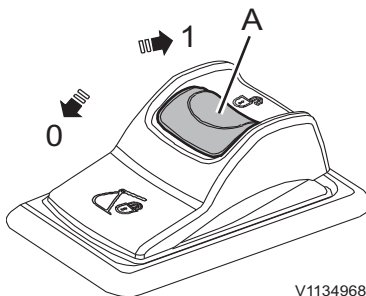

V1134968

Attachment quick coupler switch, right

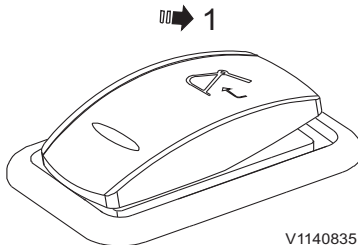

V1140835

Attachment quick coupler switch, left

- 3 Press the left attachment quick coupler switch for more than 0.7 seconds to open the attachment quick coupler. The switch is returned automatically. See page 36 for more information.

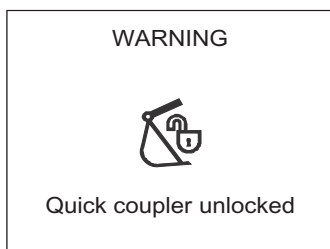

V1147254

Warning! Quick coupler unlocked

### NOTE!

When the attachment quick coupler is open, the buzzer sounds and the warning message and indicator are displayed on the IC (Instrument Cluster).

## 224 Operating techniques Attachments, connecting and disconnecting

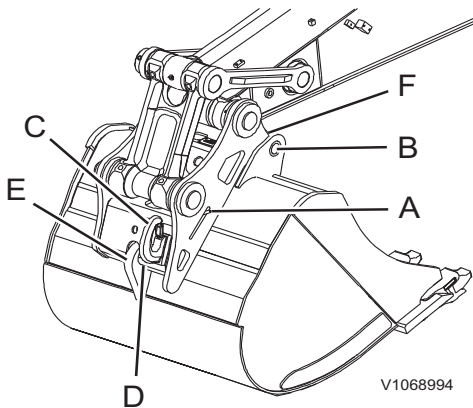

- A Red indicator pin
- B Bucket pins
- C Lift hook
- D Lock wedge
- E Bucket rear hook
- F Hooks for gripping attachment

- 4 When the red indicator pin (A) on the quick coupler is extended completely, carefully release the bucket from the attachment quick coupler by operating the bucket cylinder to its inner end position (bucket out).

**NOTE!**

If the red indicator pin (A) is not extended, increase the hydraulic pressure to the lock cylinder by carefully moving the bucket cylinder to its outer end position (bucket in), and keeping it under pressure for about a second.

- 5 Disconnect the bucket by extending the dipper arm and raising the boom.

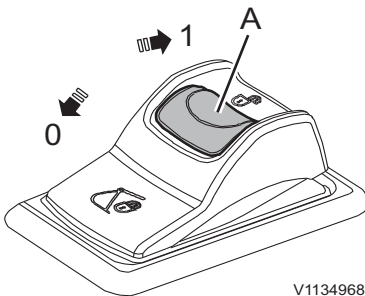

Attachment quick coupler switch, right

- 6 Press the right attachment quick coupler switch to position (0) to close the attachment quick coupler. See page 80 for more information.

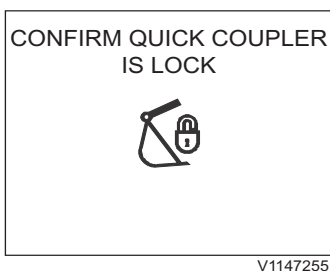

Confirm quick coupler is locked

**NOTE!**

When the switch is in position (0), the buzzer sounds and the check message for confirming and indicator are displayed on the IC (Instrument Cluster).

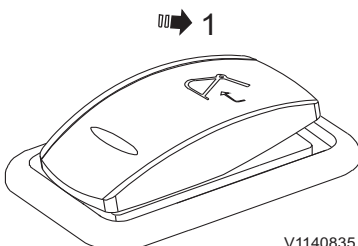

Attachment quick coupler switch, left

- 7 Press the left attachment quick coupler switch for more than 0.7 seconds to confirm that the attachment quick coupler is locked. Then the buzzer sound will be turned off and the check message and indicator will disappear. See page 36 for more information.

## Bucket, installing

### WARNING

Risk of crushing!

Attachments that move unexpectedly can cause injuries.

**Make sure people stay out of the working area when connecting or disconnecting attachments.**

- 1 Position the machine on even, firm and level ground.
- 2 Press down to release the red lock device (A) on the right attachment quick coupler switch and then press the switch to position (1) to initiate the attachment quick coupler.

When the attachment quick coupler is initiated, the buzzer sounds and the check message and indicator are displayed on the IC (Instrument Cluster). See page 80 for more information.

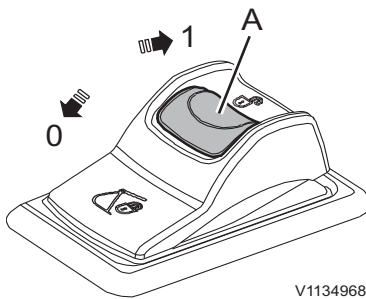

V1134968

Attachment quick coupler switch, right

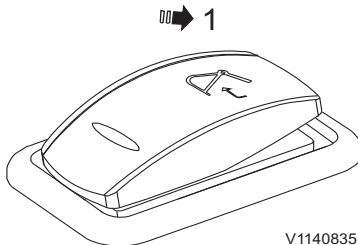

V1140835

Attachment quick coupler switch, left

- 3 Press the left attachment quick coupler switch for more than 0.7 seconds to open the attachment quick coupler. The switch is returned automatically. See page 36 for more information.

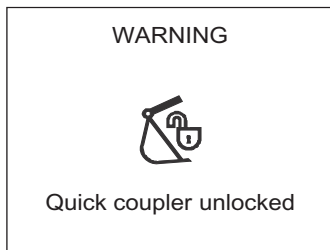

V1147254

Warning! Quick coupler unlocked

### NOTE!

When the attachment quick coupler is open, the buzzer sounds and the warning message and indicator are displayed on the IC (Instrument Cluster).

## 226 Operating techniques Attachments, connecting and disconnecting

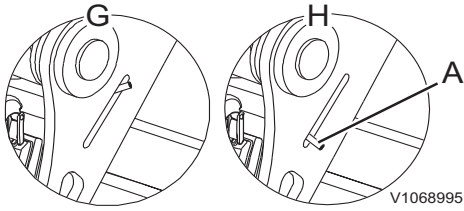

- G Indicator pin fully retracted : lock position
- H Indicator pin fully extended : unlock position
- A Red indicator pin

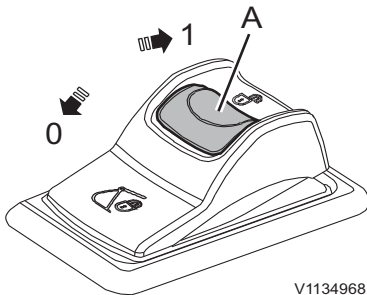

Attachment quick coupler switch, right

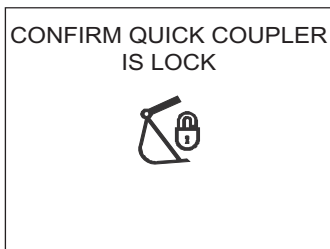

Confirm quick coupler is locked

- 4 Check that the red indicator pin (A) is fully extended.

**NOTE!**

If the red indicator pin (A) is not extended, increase the hydraulic pressure to the lock cylinder by carefully moving the bucket cylinder to its outer end position (bucket in), and keeping it under pressure for about a second.

- 5 Operate the dipper arm to such a position that the two hooks on the attachment quick coupler engage the bucket's front pin.
- 6 Slowly turn the attachment quick coupler towards the bucket by moving the bucket cylinder (bucket in) until the quick coupler mates correctly against the bucket.
- 7 Check that the attachment quick coupler is correctly aligned against the tip of the bucket, if necessary, adjust with dipper arm or boom movements.
- 8 Press the right attachment quick coupler switch to position (0) to close the attachment quick coupler. See page 80 for more information.

**NOTE!**

When the switch is in position (0), the buzzer sounds and the check message for confirming and indicator are displayed on the IC (Instrument Cluster).

## Operating techniques

# Attachments, connecting and disconnecting 227

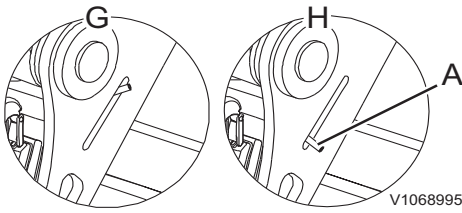

- G Indicator pin fully retracted  
: lock position
- H Indicator pin fully extended  
: unlock position
- A Red indicator pin

9 Check that red indicator pin (A) is fully retracted into the attachment quick coupler.

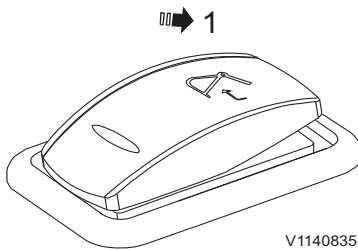

Attachment quick coupler switch, left

10 Press the left attachment quick coupler switch for more than 0.7 seconds to confirm that the attachment quick coupler is locked. Then the buzzer sound will be turned off and the check message and indicator will disappear. See page 36 for more information.

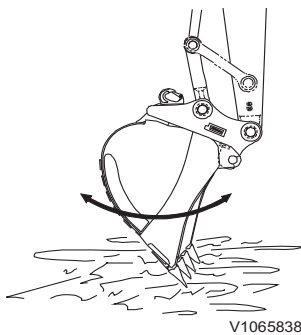

- 11 Do the following tests to check that the attachment quick coupler is fastened securely.
- Press the bucket against the ground.
  - Operate the bucket cylinder in and out to check that lock wedge (D) is seated securely. If you are not sure, check that lock wedge (D) has gone into the hook.
  - Do not use the machine if the attachment quick coupler is not working.
  - Contact a workshop authorized by Volvo if anything is wrong.

### **WARNING**

Risk of crushing.

If the red warning lamp for open attachment bracket lights up while working, the attachment could fall off and cause serious crushing injury or death.

**Stop working with the machine immediately and make sure the attachment bracket is properly locked before starting to work again.**

## 228 Operating techniques Attachments, connecting and disconnecting

### S1 quick coupler, adjusting

Periodic checks must be performed on the quick coupler. Check the quick coupler every 10 hours or daily, especially when operating the machine in severe or harsh conditions.

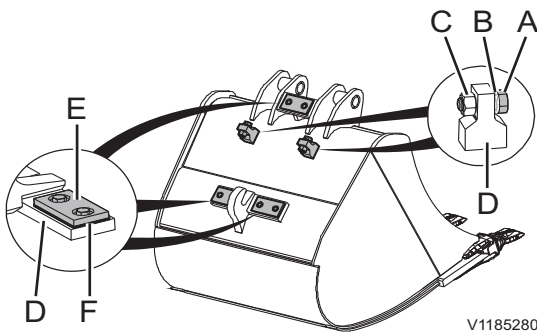

- A Screw
- B Washer + shim
- C Nut
- D Screw holder
- E Spacer
- F Shim

- 1 Remove the bucket, referring to the bucket removal instructions.
- 2 Remove shims (B) between screw holder (D) and screw (A) in 2 places, as shown in the illustration. Replace the screws back in their original positions.
- 3 Remove shims (F) between screw holder (D) and spacer (E) in 3 places, as shown in the illustration. Replace the spacers back in their original positions and tighten the mounting bolts.

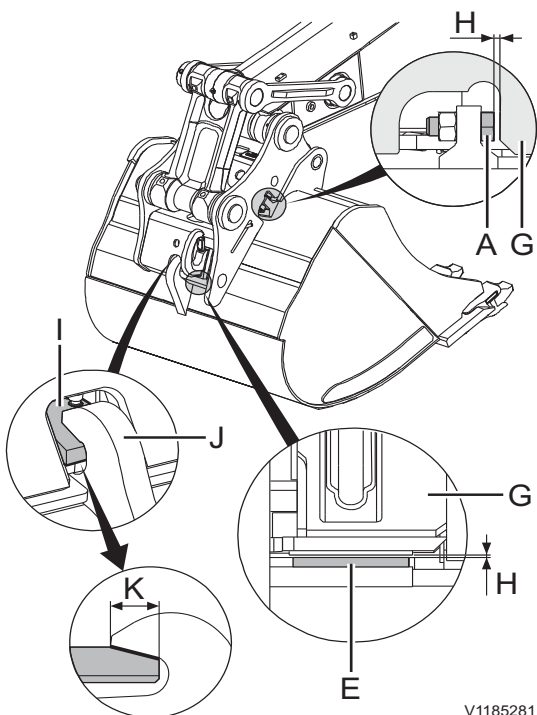

- G Attachment quick coupler
- H Gap
- I Lock wedge
- J Bucket rear hook
- K Recommended length of the mating surface (more than 60 mm (2.4"))

- 4 Install the bucket, referring to the bucket installation instructions.
- 5 Confirm that lock wedge (I) is fully engaged in the mating hook.

#### NOTE!

It is important to check that the lock wedge (I) sinks deep enough down into the hook (J). It is recommended that the lock wedge is engaged into the hook more than 60 mm (2.4") (K). Visually inspect to verify the lock wedge is in the correct position.

- 6 Measure gaps (H) between screws (A) and the corresponding mating surface of the quick coupler (G). Bucket should be gently operated as needed to obtain maximum possible gap and this should be done in each of the 2 places independently.
- 7 Measure gaps (H) between spacers (E) and the corresponding mating surface of the quick coupler (G). Bucket should be gently operated as needed to obtain maximum possible gap and this should be done in each of the 3 places independently.
- 8 Remove the bucket, referring to the bucket removal instructions.
- 9 Unscrew screw (A) and add shims (B) between screw holder (D) and screw for the thickness of



## Operating techniques Attachments, connecting and disconnecting 229

---

the gap measured in procedure 6. Tighten the screw, and lock it with the nut. Contact your Volvo dealer for information on the correct shims.

- 10 Unscrew the spacer mounting bolts and add shims between spacer (E) and screw holder (D) for the thickness of the gap measured in procedure 7. Tighten the spacer mounting bolts. Contact your Volvo dealer for information on the correct shims.
- 11 Install the bucket again and check the gap in the same way as in procedures 6 and 7.
- 12 If there is still a gap, measure the gap and add the required thickness of shims. Or if the quick coupler cannot hook the bucket completely into its mating surface due to interference, reduce the thickness of shims.
- 13 Repeat this process until the gap is removed in each of the 5 places between the bucket and quick coupler.

### **NOTE!**

Operating with a bucket not tightly mounted, with a gap, will significantly increase wear and tear on the quick coupler.

## Attachment quick coupler

### Universal quick coupler (optional equipment)

#### **WARNING**

Risk of crushing.

Falling attachments could result in severe injury or death.

**Make sure the attachment bracket is properly locked before starting work.**

#### **WARNING**

Risk of crushing.

An unsecured attachment could fall and cause serious injury or death.

**Always ensure the attachment is properly secured by pressing the front part of the attachment to the ground until the machine is slightly lifted.**

The attachment quick coupler is equipped with a double-acting hydraulic cylinder. The hook for gripping the attachment is fitted to its piston rod. The hydraulic system's pressure acts on the lock cylinder's piston, locking the attachment in place against the rear bucket pin. This means that the hook adjusts itself and provides gap-free locking.

When checking from the cab if the attachment quick coupler is locked or unlocked, slowly curl out the bucket/attachment and dipper arm.

With the lifting eye, the machine can be used for lifting operations. Since the lifting eye is located on the attachment quick coupler, it can be used without bucket. This improves visibility for the operator and increases the maximum permissible load.

#### **NOTE!**

See page 250 for information on lifting objects.



## Operating techniques

# Attachments, connecting and disconnecting 231

### Bucket, removing

#### **WARNING**

Risk of crushing!

Attachments that move unexpectedly can cause injuries.

**Make sure people stay out of the working area when connecting or disconnecting attachments.**

- 1 Place the machine on firm and level ground.
- 2 Curl in the bucket completely towards the dipper arm (to release the lock mechanism).

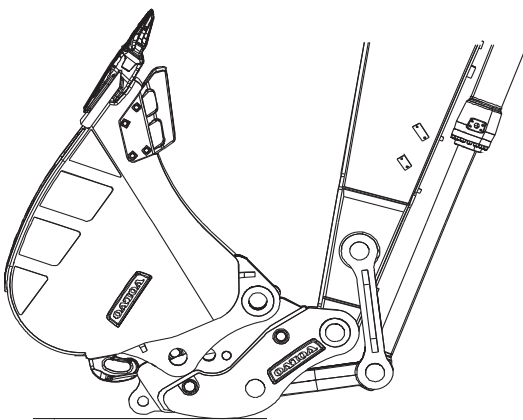

D

V1190909

D = 200 mm (7.87 inches)

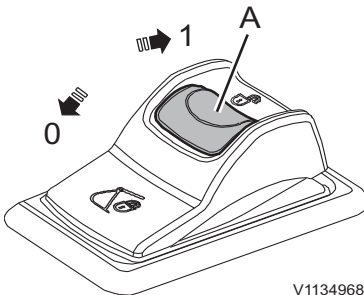

V1134968

Attachment quick coupler switch, right

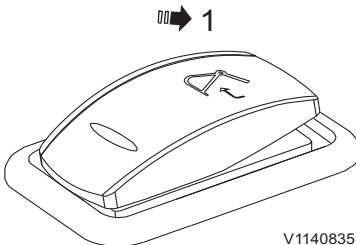

V1140835

Attachment quick coupler switch, left

- 3 Press down to release the red lock device (A) on the right attachment quick coupler switch and then press the switch to position (1) to initiate the attachment quick coupler.

When the attachment quick coupler is initiated, the buzzer sounds and the check message and indicator are displayed on the IC (Instrument Cluster). See page 80 for more information.

- 4 Press the left attachment quick coupler switch for more than 0.7 seconds to open the attachment quick coupler. The switch is returned automatically. See page 36 for more information.

## 232 Operating techniques Attachments, connecting and disconnecting

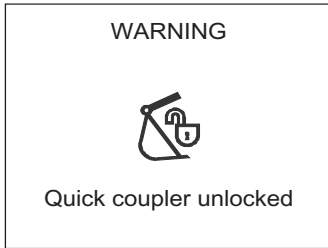

V1147254

Warning! Quick coupler unlocked

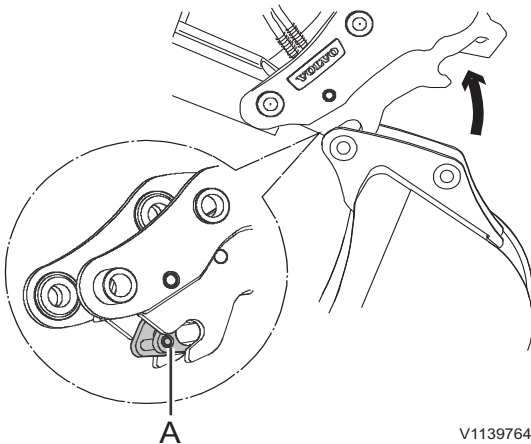

V1139764

Attachment quick coupler, unhooking  
A Front lock device

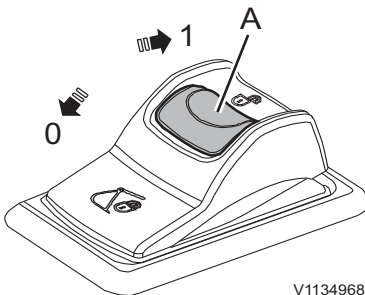

V1134968

Attachment quick coupler switch, right

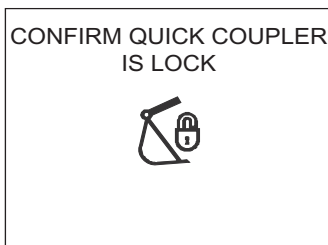

V1147255

Confirm quick coupler is locked

### NOTE!

When the attachment quick coupler is open, the buzzer sounds and the warning message and indicator are displayed on the IC (Instrument Cluster).

- 5 Make sure that the front lock device (A) is fully opened to unhook from the bucket pin. Otherwise, the bucket pin cannot disengage correctly.

### NOTE!

If the front lock device (A) is not opened, increase the hydraulic pressure to the lock cylinder by carefully moving the bucket cylinder to its outer end position (bucket in), and keeping it under pressure for about a second.

- 6 Lower the bucket and curl out to lift up the attachment quick coupler from the bucket.
- 7 Place the bucket flat on the ground and unhook it.
- 8 Press the right attachment quick coupler switch to position (0) to close the attachment quick coupler. See page 80 for more information.

### NOTE!

When the switch is in position (0), the buzzer sounds and the check message for confirming and indicator are displayed on the IC (Instrument Cluster).

## Operating techniques

# Attachments, connecting and disconnecting 233

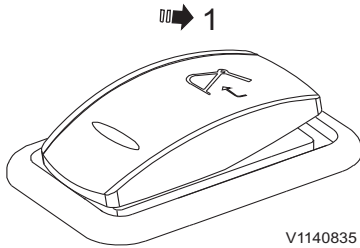

Attachment quick coupler switch, left

- 9 Press the left attachment quick coupler switch for more than 0.7 seconds to confirm that the attachment quick coupler is locked. Then the buzzer sound will be turned off and the check message and indicator will disappear. See page 36 for more information.

234 Operating techniques  
Attachments, connecting and disconnecting

Bucket, installing

**WARNING**

Risk of crushing!

Attachments that move unexpectedly can cause injuries.

**Make sure people stay out of the working area when connecting or disconnecting attachments.**

- 1 Place the machine on firm and level ground.
- 2 Curl in the bucket completely towards the dipper arm (to release the lock mechanism).

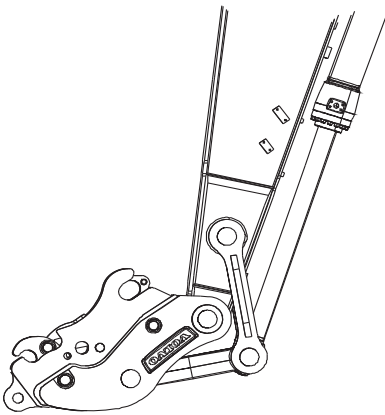

V1190910

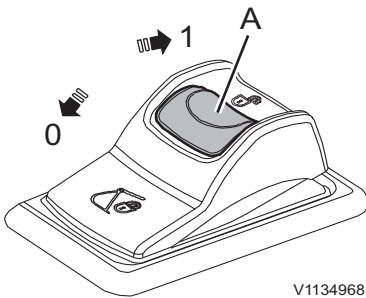

V1134968

Attachment quick coupler switch, right

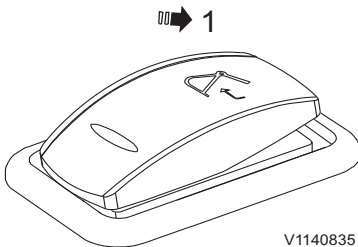

V1140835

Attachment quick coupler switch, left

- 3 Press down to release the red lock device (A) on the right attachment quick coupler switch and then press the switch to position (1) to initiate the attachment quick coupler.

When the attachment quick coupler is initiated, the buzzer sounds and the check message and indicator are displayed on the IC (Instrument Cluster). See page 80 for more information.

- 4 Press the left attachment quick coupler switch for more than 0.7 seconds to open the attachment quick coupler. The switch is returned automatically. See page 36 for more information.

## Operating techniques

# Attachments, connecting and disconnecting 235

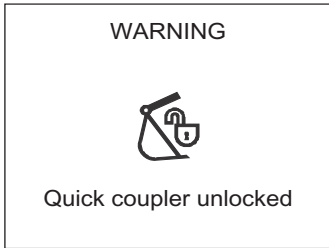

V1147254

Warning! Quick coupler unlocked

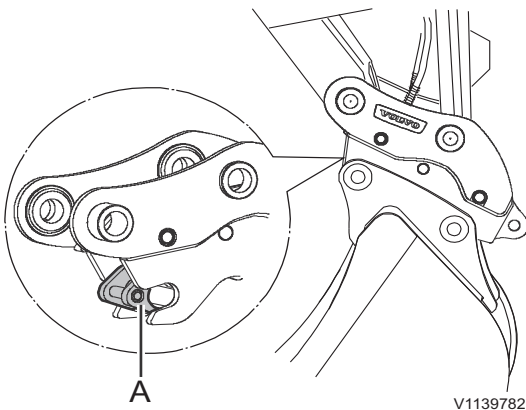

V1139782

Bucket in locked position  
A Front lock device

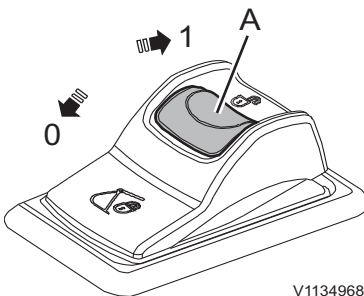

V1134968

Attachment quick coupler switch, right

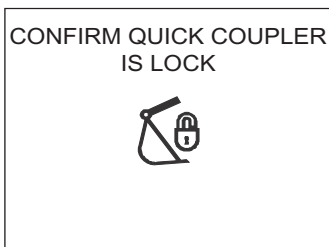

V1147255

Confirm quick coupler is locked

### NOTE!

When the attachment quick coupler is open, the buzzer sounds and the warning message and indicator are displayed on the IC (Instrument Cluster).

- 5 Make sure that the front lock device (A) is fully opened before hooking it onto the bucket pin. Otherwise, the bucket pin cannot be engaged correctly.

### NOTE!

If the front lock device (A) is not opened, increase the hydraulic pressure to the lock cylinder by carefully moving the bucket cylinder to its outer end position (bucket in), and keeping it under pressure for about a second.

- 6 Curl out the attachment quick coupler and hook it onto the bucket pin.
- 7 Slowly curl in the attachment quick coupler fully towards the bucket.
- 8 Press the right attachment quick coupler switch to position (0) to close the attachment quick coupler. See page 80 for more information.

### NOTE!

When the switch is in position (0), the buzzer sounds and the check message for confirming and indicator are displayed on the IC (Instrument Cluster).

- 9 Visually check that the front lock device is fully engaged.
- 10 Lift and curl in the bucket fully towards the dipper arm and hold it there for approximately 5 seconds to ensure that the attachment quick coupler has locked securely to the bucket.

## Operating techniques

### 236 Attachments, connecting and disconnecting

1

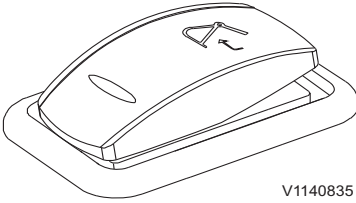

V1140835

Attachment quick coupler switch, left

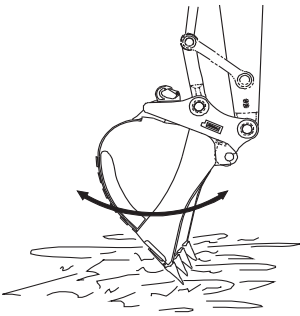

V1065838

11 Press the left attachment quick coupler switch for more than 0.7 seconds to confirm that the attachment quick coupler is locked. Then the buzzer sound will be turned off and the check message and indicator will disappear. See page 36 for more information.

12 Do the following tests to check that the attachment quick coupler is fastened securely.

- Press the bucket against the ground. In this position, curl the bucket in and out to check that it is locked in the correct position.
- If you are uncertain about whether the bucket is securely locked to the attachment quick coupler, get out and check that the front lock device is fully engaged.
- Do not use the machine if the attachment quick coupler is not working.
- Contact a workshop authorized by Volvo if anything is wrong.

### WARNING

Risk of crushing.

If the red warning lamp for open attachment bracket lights up while working, the attachment could fall off and cause serious crushing injury or death.

**Stop working with the machine immediately and make sure the attachment bracket is properly locked before starting to work again.**

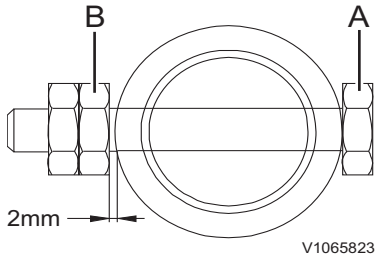

## Buckets

### Bucket, changing Bucket, removal

#### **WARNING**

Risk of splinter injury.

Striking the bucket pin with a hammer could cause metal chips to fly around and cause serious splinter injury.

**Always wear face and eye protection, hard hat and gloves while removing and installing the bucket pins.**

- 1 Lower the bucket lightly on the ground.
- 2 Remove the lock screw (A) and nut (B) of each pins.
- 3 Remove pins (C and D) and O-rings (E), then remove the bucket.

#### **NOTICE**

**Block the removed bucket to stabilise it. Keep the pins clean and do not damage the O-ring.**

#### Bucket, Installation

#### **CAUTION**

Risk of cutting and crushing.

Loose parts could cause crushing and cutting injury.

**Never use your fingers for checking alignment between loose parts. Always use a tool.**

- 1 Align the dipper arm and links to the bucket.
- 2 Put O-rings (E) at the holes for the dipper arm and link. Align the holes between bucket and dipper arm and links.
- 3 Apply grease to the holes.
- 4 Insert pins (C and D).
- 5 Install lock screw (A) and nut (B) of each pins.

#### **NOTICE**

**Make sure that there is a clearance of at least 2 mm (0.08 in) between nut and pin boss. Lubricate the pin.**

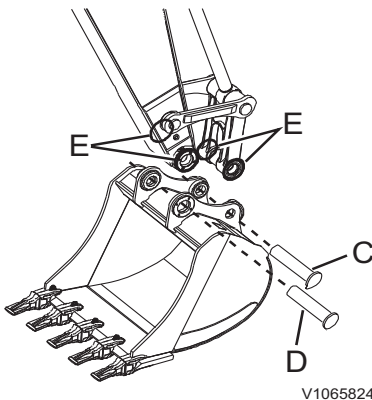

## Working with buckets

### NOTICE

Select a suitable attachment that fits the machine on which it is to be installed. The types of attachments that can be installed vary with the machine type. Contact a workshop authorised by Volvo.

The machine is prepared for several different type of optional equipment to perform many types of work. Only the simplest operations are described below.

### Backhoe work

Backhoe work is digging the material at a lower level than the machine is located.

When the angle between bucket cylinder and links, dipper arm cylinder and dipper arm is set to  $90^\circ$  respectively, the working efficiency of each cylinder will be at its maximum. Take advantage of this angle to improve the work efficiency. The range for effective digging is when the dipper arm is between  $30^\circ$  forward and  $45^\circ$  rearward. There may be a little difference according to digging depth. Do not use the cylinder up to its stroke end, but only within this range.

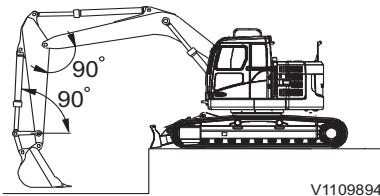

V1109894

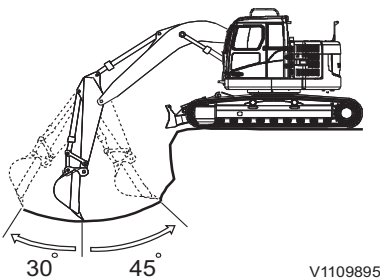

V1109895

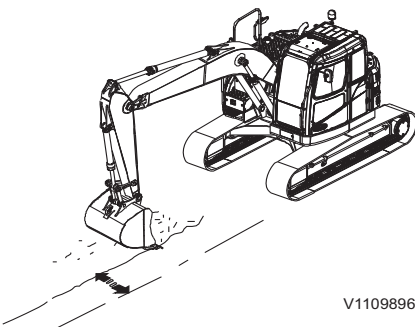

V1109896

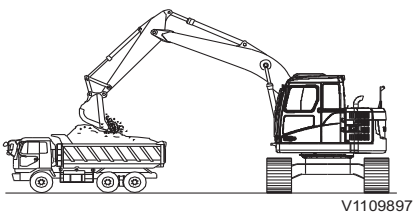

V1109897

### Ditching work

Install a proper bucket for ditching. Place the machine where the ditching is performed effectively.

In case of a wide ditch, dig both sides in first, and then dig the center area.

### Loading work

Position the hauler or truck so as to achieve a small swing movement and good visibility for the operator to work effectively.

Also load over the rear side of the dump truck rather than over the side, as this makes the operator work easier and increases efficiency.



## Hammer

### Hammer (hydraulic breaker)

Select the proper attachment in accordance with the machine on which the attachment is installed. The type of attachment which is able to be installed varies with the machine type.

Use only hydraulic breaker that is recommended by Volvo. Contact an authorized Volvo dealer workshop.

#### **NOTE!**

For complete instructions for the hydraulic breaker, read the separate Operator's Manual for the hammer.

Do not operate the hydraulic breaker until you read and understand both machine and hydraulic breaker manuals.

#### **NOTE!**

Lubricate the excavator units (such as boom, arm and linkages) twice a day.

If the machine is provided with an attachment quick coupler, this must be checked every day at the same time as rectifying any play.

### **WARNING**

Risk of severe personal injury.

While working with the hammer flying chips of rock could cause severe injury.

**Provide protective nets for the windscreens. Keep windows and door closed and prevent persons from entering the risk zone when operating the hydraulic breaker.**

240 Operating techniques  
Hammer

Main works

**NOTE!**

The machine images in this section are one of excavator's images. However the guideline is valid for all excavators.

- Breaking stone
- Demolition work
- Road repairing

It is widely used for demolition of buildings, breaking road surfaces, tunneling work, smashing slag, and breaking or cutting stone.

Press the tool (chisel) firmly onto the surface at a right angle as shown.

**NOTE!**

The standard hydraulic breaker must not be used under water. If the water fills the space where the piston strikes the tool, a strong pressure wave is generated and the hydraulic breaker may be damaged.

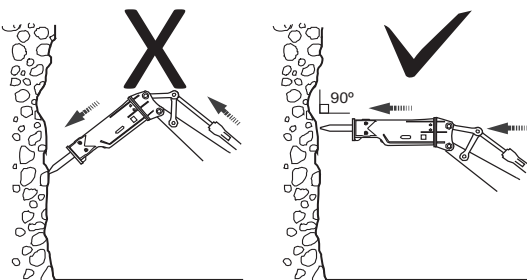
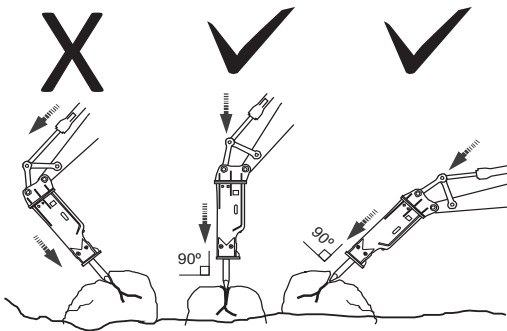

V1111448

## Operating techniques Hammer 241

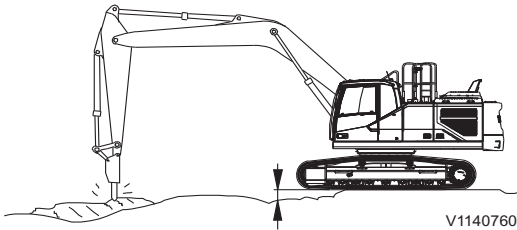

When striking, press the tool firmly onto the surface, and lift the frame about 5cm. Never raise the machine unnecessarily high.

### NOTE!

When operating the breaker, track motors should be located at rear position to prevent motors damage.

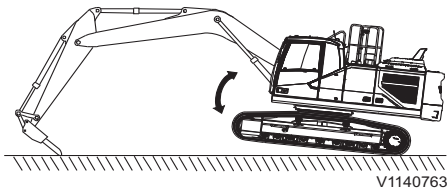

Do not raise the machine by extending the bucket cylinder to maximum.

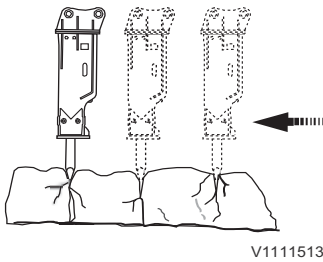

If the surface is repeatedly struck but it is not broken within 30 seconds, move the hydraulic breaker to break from the end portion.

Also If the block has not cracked after a series of approx. ten strokes, change the point of attack.

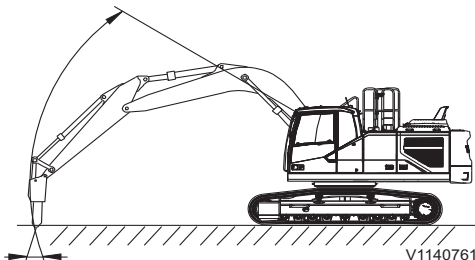

The striking direction of tool and hydraulic breaker body are slightly deviated. Therefore, adjust the bucket cylinder so that the direction of body and tool is always the same.

## 242 Operating techniques Hammer

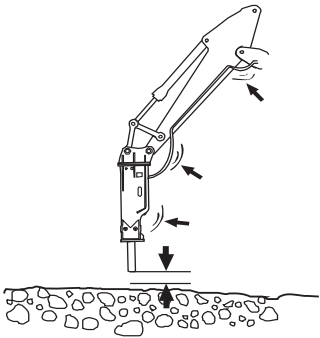

V1111449

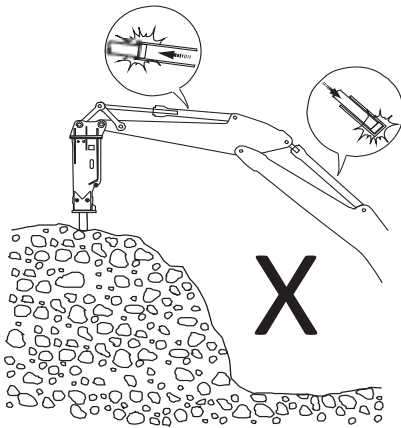

V1148361

Listen to the sound of the hydraulic breaker when you are using it. If the sound becomes weaker and the impact less efficient, the tool is misaligned with the material and/or there is not enough feed force on the tool. Realign the tool and press the tool firmly against the material.

Stop operation if hydraulic hoses shaking abnormally. Immediately stop the operation.

Otherwise this may result in serious failure in the hydraulic system including pumps. Check gas pressure of back head and accumulator and charge the pressure to recommended value. See the breaker manual for detail.

Do not operate the bucket, arm and boom cylinders to their end positions than 10 cm (4 in) to prevent cylinder's damage.

Operating techniques  
Hammer 243

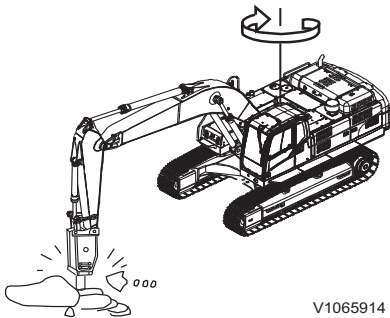

V1065914

Do not swing the machine while breaking work

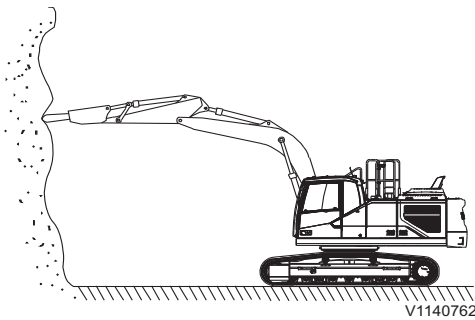

V1140762

Avoid working with the hydraulic breaker horizontally or in an upward direction. This will cause great wear.

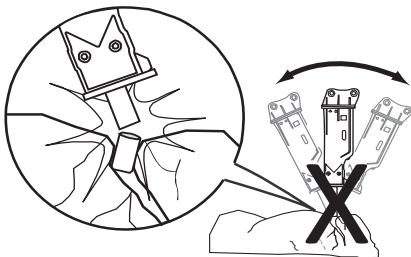

V1111512

Do not bend with the tool to make a hole in the ground.

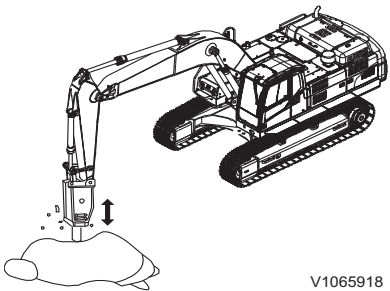

V1065918

Do not break the materials using drop force of boom. The machine structure can be damaged. Press the tool firmly against the surface so idle striking is avoided. Do not move the tool while it is striking a blow.

244 Operating techniques  
Hammer

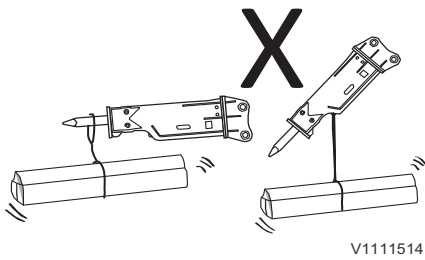

The hydraulic breaker is not designed to lift or transport loads. The hydraulic breaker may easily be damaged and it is very dangerous.

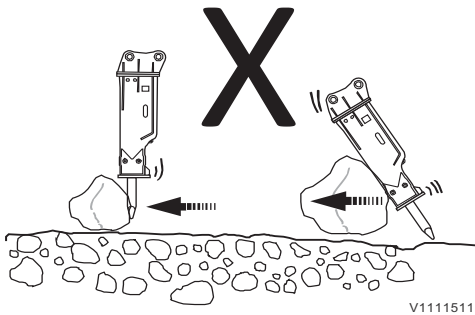

Avoid moving and gathering the objects using hydraulic breaker.

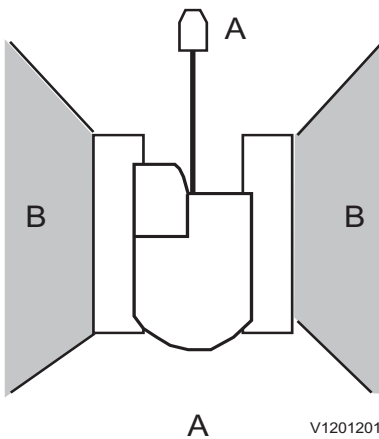

The best working area is in the longitudinal direction of the undercarriage and within an approximate 45° sector in both directions (A). Do not operate the hydraulic breaker at (B) area. The machine can be unstable and undercarriage component may be failure as a result from excessive loads on the undercarriage.

- A Longitudinal direction of the undercarriage
- B Across undercarriage: not recommended



## Working with long range attachments

### **NOTICE**

With certain attachment combinations there is a risk that the attachment may strike the cab. Avoid damage by being careful when working close to the machine.

### **NOTICE**

Only attachments approved for the machine by Volvo may be used.

Long range attachments can be used in clearing and dredging lump of clay accumulated in the river and reminders of waste water effectively.

- Do not use long-range attachment in general excavating, because it is designed for excavating small amounts.
- Operate the machine smoothly in order to keep stability and safety when travelling.
- Do not stop the machine abruptly, which may cause heavy joggling of the attachment. It also causes excessive force to the attachments which finally may damage the machine.
- Never use power boost switch with long reach boom and arm.
- Boom, dipper arm and bucket have big inertial power compared to standard equipments. Therefore, do not operate the machine at the ends of stroke of each cylinder.
- Do not travel the machine or raise the main body with the bucket grounded. It may give excessive force to pin around the bucket.

## Hose rupture valves

(Optional equipment)

### NOTICE

Do not dismantle the hose rupture valve as it is pressurised. Contact a workshop authorised by Volvo if problems arise.



### WARNING

Risk of serious injury.

Working under an attachment that is not properly supported could cause serious injury.

**Before working under an attachment, ensure the attachment is properly supported and the control lockout lever has been locked and the engine is shut off. Ensure that nobody enters the cab while working under the attachment.**

### Attachment lowering after hose rupture

#### When engine is running

Lower the boom or dipper arm with the operating levers in the usual way. Collect the oil from the ruptured hose in a suitable vessel.

#### When engine is stopped

The servo hydraulic pressure is maintained by a pressure in accumulator for a few minutes, which permits the operator to lower the boom or dipper arm in the usual way with operating levers. Do not wait too long to lower the boom, the servo hydraulic pressure will reduce at a speed depending on your machine's condition and equipment. Collect the oil from the ruptured hose in a suitable vessel.



## Operating techniques Hose rupture valves 247

When engine is stopped and with no servo hydraulic pressure

### WARNING

Risk of high pressure injection.  
The hydraulic oil is under high pressure.  
Discharging hydraulic oil will cause serious injury when injected into the skin.

**Depressurize the hydraulic system before connecting or disconnecting hydraulic hoses.**

### NOTICE

Always use personal protective equipment, such as working gloves, overalls and face protection or protective goggles with side protection before you release excess pressure in a hydraulic hose or pipe connection.

- 1 Loosen lock nut (B) and turn adjusting screw (A) counter-clockwise slowly.  
**Before turning the adjusting screw, mark its position to facilitate assembling later (setting pressure: 37.8 MPa, 385 kgf cm<sup>2</sup>, 5482 psi)**  
The boom will then slowly be lowered to the ground.
- 2 Turn adjusting screw (A) to its original position.
- 3 Hold adjusting screw (A) securely and tighten lock nut (B).
- 4 Contact an authorized Volvo Construction Equipment dealer workshop.

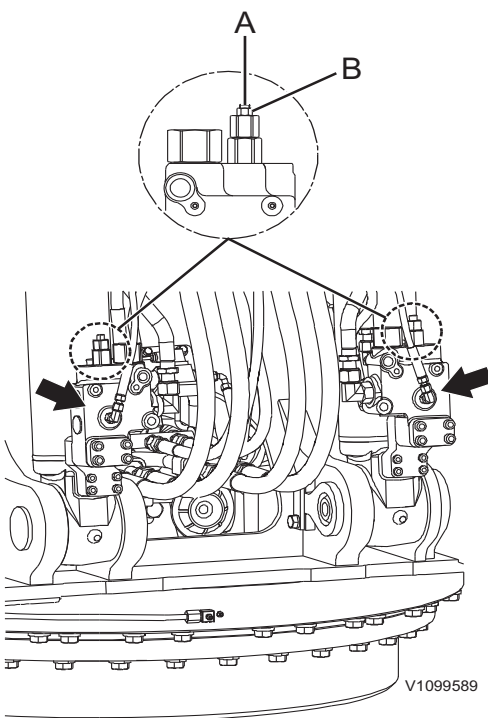

Hose rupture valves  
A Adjusting screw  
B Lock nut



## Selecting track shoes

Grouser	Use	Precautions when using
A 600 mm	Rocky ground, normal soil	Travel in low speed when travelling on rough ground with obstacles such as large boulders and fallen trees.
B 700 mm 800 mm	Soft ground	Travel in high speed only on flat ground. When it is impossible to avoid travelling over obstacles, lower the travel speed to approximately half of low speed. <b>NOTE!</b> Cannot be used on rough ground where there are large obstacles such as boulders or fallen trees.
C 900 mm	Extremely soft ground (boggy ground)	Use only for ground where "A" and "B" are impossible to use. Travel in high speed only on flat ground. When it is impossible to avoid travelling over obstacles, lower the travel speed to approximately half of low speed. <b>NOTE!</b> Cannot be used on rough ground where there are large obstacles such as boulders or fallen trees.
D Rubber shoe/ pad	Pavement	Use only on pavement <b>NOTE!</b> Cannot be used on rough ground

### Rubber shoe/pad usage

When using rubber shoe/pad, keep the following in mind.

#### 1 Ground condition

- Use rubber shoe/pad only on pavement. Otherwise the durability is rapidly reduced due to the rubber shoe/pad cut-off and wear especially on:
  - concrete crushed pieces
  - sand
  - reinforcing bars
  - projected pieces of glass
- Do not use rubber shoe/pad when travelling on concrete sidewalks, on rocky ground, or on stony river beds.
- Be careful not to slip on water, snow or sand. Especially be careful when loading and unloading the machine.
- Durability of the rubber track may not be guaranteed with special attachment mounted.



## Operating techniques Selecting track shoes 249

---

### 2 Driving techniques

- Driving slowly and turning with a large radius compared to fast small radius turns will extend shoe/pad life.
- High friction caused by fast turns on concrete surfaces can lead to detracking and rubber abrasion.

### 3 Storage, maintenance

- Keep rubber shoe/pad oil and grease free.
- If long-term storage of the rubber shoe/pad is required, store from direct sun light or rain.
- Rubber shoe/pad can operate problem-free within a temperature range of  $-25^{\circ}\text{C} \sim +55^{\circ}\text{C}$ .



## Lifting objects

There may be local and/or national regulations that govern the use of machines which apply for lifting operations. Obey the local and/or national regulations. Contact your local Volvo dealer for more information.

If the machine is used to lift objects within an area that is governed by the European Machinery Directive 2006/42/EC and its amendments, the machine must be equipped with following working devices.

- A load hooking device.
- A hose rupture valve on the boom or in some countries hose rupture valve on both boom and dipper arm is required depending on risk assessment. See page 246.
- A overloading warning device. See page 80.

Safe lifting make great demands on the operator. Read the below recommended steps before starting any lifting.

- Use qualified and properly trained operators who have:
  - Specific machine knowledge and training.
  - Read and understand the operator's manual and its load charts. See page 380.
  - Specific machine knowledge and training how to properly rig the load.
  - Full responsibility for all aspects of the lift.
- Interrupt the lift if not fully confident of a safe lift.
- Select machine with sufficient capacity for the total expected load, reach and swing. Ideally, load should be less than the load listed on the load chart at maximum reach across the undercarriage. See page 380.
  - Know the mass (weight) of the item to be lifted.
  - Know the start and finish positions, load lifting position and setting position.
  - Know the machine configuration, especially the dipper arm and boom lengths and counterweight mass.
  - Choose the correct lifting chart taking into account all attachments and rigging materials that will be used during the lift. The weight of the rigging materials and attachments, should be deducted from the load capacity.
- Warm up the machine to normal working temperatures.



- Position the machine on firm level ground.
- Properly set outriggers and blade when applicable.
- Visually inspect the rigging materials for defects, cracks, or any other damage before lifting objects.
- Once the load is properly rigged, ensure all ground workers are clear of the load and the machine. If guiding of the load is necessary, use ropes or other type of slings tied to the load to keep ground workers at a safe distance.
- Use a trained signaller to direct all aspects of the move.

### **NOTICE**

**It is the responsibility of the owner or the operator to know and follow the local or national regulations that apply for lifting operations. For further information, contact your dealer.**

Keep the following in mind to ensure the highest level of controllability and safety when lifting.

- Operate on solid, flat, level ground.
- If ground conditions are unstable, for example loose gravel, sand or water, do not work with loads close to the rated load maximums given on the machine load chart.
- Do not swing the excavator abruptly with a suspended load, the effects of centrifugal force will impair machine stability.
- Do not use the swing or dipper arm-in operation to drag a load.
- Do not operate the machine while someone is hanging on or in the bucket or attachments.

## 252 Operating techniques Lifting objects

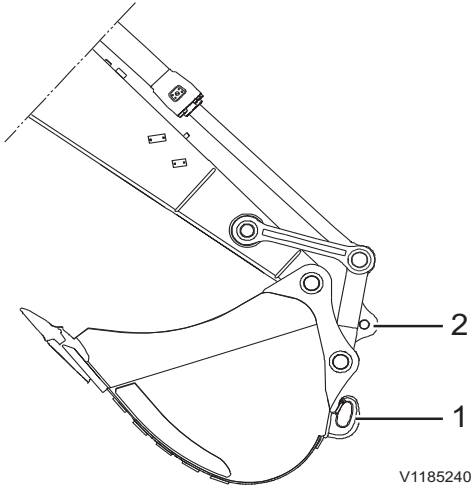

- 1 Lifting device on bucket
- 2 Lifting device on connecting rod

### 1 Load hooking device on bucket or attachment quick coupler

The lifting device whether mounted on a bucket or other attachment must not be subjected to lateral loads. The load must be applied longitudinally to the hook.

Always ensure that the load lies within the marked permissible lifting load of lifting device when manoeuvring the dipper arm and bucket.

Exceeding these limits can cause serious injury.

Remember that the operator is responsible in case of an accident.

#### NOTE!

Lifting capacity of hook on the bucket or attachment quick coupler could be lower than the machine's lifting capacity.

Visually check that the max. lifting capacity of hook marked on the bucket or attachment quick coupler. If the marking for lifting capacity on the bucket or attachment quick coupler is worn out, contact an authorized Volvo dealer for the information.

#### NOTE!

This represents the capacity of the hook and not the rated load capacity of the machine which varies according to ground conditions, reach, travel position and so on.

#### NOTE!

Only use lifting device recommended by Volvo in order to avoid damage to the machine. Contact your dealer for information regarding other lifting device.

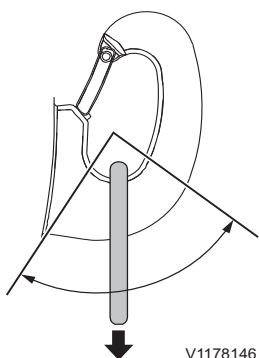

Permissible working range of lifting hook

### WARNING

Risk of crushing.

A lifting hook loaded outside the permissible working range could cause the load to fall off and lead to serious crushing injury or death.

**Never load the lifting hook outside the permissible working range.**

#### NOTE!

Bear in mind that the lifting capacity of the machine is greater when the attachment is pulled in closer to the machine.



Lifting equipment and lifting hook must be clean and in a serviceable condition. Before lifting, check that the lifting device is correctly secured.

### **WARNING**

Risk of fatal accidents.

A suspended load could drop if the hydraulic system fails and cause fatal accidents and serious injury or death.

**Never leave the machine with a suspended load.**

## **2 Load hooking device on connecting rod**

Lifting device on connecting rod is designed to lift the marked permissible load on the lifting device. Consider also the lifting capacity of your machine, see page 380.

## Overload warning

### NOTICE

The overload warning does not give the actual machine limit, but constitutes an indication of a potential risk of tipping over in case of deteriorating stability.

The overload warning is engaged and disengaged using the button on the machine control keypad, see page 80.

### NOTICE

The overload warning must always be engaged when lifting a suspended load.

When an overload is registered, the central warning lamp and the control lamp illuminate on the IC (Instrument Cluster) and the buzzer sounds. When digging, the overload warning should be disengaged.



V1065467

Overload warning (Red)

## Overload warning pressure

Default pressure of the overload warning system is 190 bar (2756 psi).

### NOTE!

Overload warning pressure must be below the rated lifting capacity in accordance with European Machinery Directive 2006/42/EC, local and/or national government regulations. Contact your local Volvo dealer for more information.

If the default pressure needs to be adjusted in accordance with local and/or national government regulations, contact a qualified service technician.

### ! WARNING

Risk of accidents.

Overloading could lead to a turnover of the machine or to falling load and attachments.

**Do not exceed the machine's maximum lifting capacity and never ignore the overload warning.**

Lifting capacities are based on the machines with following conditions:

- Lifting point: At the dipper arm end, without bucket





## Operating techniques

### Lifting objects 255

---

- Operator and all fluids (e.g., all the lubricants and fuel in the fuel tank are fully topped up.)
- Dozer blade/stabiliser is up (if equipped).

The values in the lifting capacities are in compliance with ISO10567. Rated loads do not exceed 87% of hydraulic lifting capacity or 75% of tipping load. See page 380 for more information.

#### **Overload warning system, checking**

##### **NOTE!**

A check of the overload warning equipment must be carried out every 1000 hours, see page 304.

## Signalling diagram

### Manual signalling to operator of a mobile excavator as per SAE J1307.

The primary use of hand signals is for a signalman to direct the lifting, handling, and placement of loads attached to working equipment. Hand signal usage may also be applicable to earthmoving operations and/or machine travel when the operator's visibility is obstructed.

If a rapid lifting, lowering or moving movement is required, the dipper arm movements should be carried out more lively. If two different machines are used for lifting the same load, there should be an agreement beforehand how the lift should be carried out and what signals should be given to the respective operators.

<p>V1065920</p>	<p>V1065921</p>	<p>V1065923</p>
<p><b>RAISE LOAD VERTICALLY</b> With either forearm vertical, forefinger pointing up, move hand in small horizontal circles.</p>	<p><b>LOWER LOAD VERTICALLY</b> With either arm extended downward, forefinger pointing down, move hand in small horizontal circles.</p>	<p><b>MOVE LOAD IN HORIZONTALLY</b> With either arm extended, hand raised and open toward direction of movement, move hand in direction of required movement.</p>
<p>V1065924</p>	<p>V1065925</p>	<p>V1065926</p>
<p><b>MOVE LOAD OUT HORIZONTALLY</b> With either arm extended, hand raised and open toward direction of movement, move hand in direction of required movement.</p>	<p><b>RAISE BOOM</b> With either arm extended horizontally, fingers closed, point thumb upward.</p>	<p><b>LOWER BOOM</b> With either arm extended horizontally, fingers closed, point thumb downward.</p>
<p>V1065927</p>	<p>V1065928</p>	<p>V1065929</p>

Operating techniques  
Signalling diagram 257

<p><b>SWING</b> With either arm extended horizontally, point with forefinger to direction of swing rotation.</p>	<p><b>DIPPER ARM INWARD</b> With both hands clenched, point thumbs inward.</p>
<p>V1065930</p>	<p>V1065931</p>
<p><b>DIPPER ARM OUTWARD</b> With both hands clenched, point thumbs outward.</p>	<p><b>CLOSE BUCKET</b> Hold one hand closed and stationary. Rotate other hand in small vertical circle with forefinger pointing horizontally at closed hand.</p>
<p>V1065933</p>	<p>V1065934</p>
	<p><b>OPEN BUCKET</b> Hold one hand open and stationary. Rotate other hand in small vertical circle with forefinger pointing horizontally at open hand.</p>
	<p>V1065935</p>
<p><b>TURN THIS FAR TO GO</b> Raise forearm with closed fist indicating inside of turn. Move other fist in vertical circle indicating direction of track or wheel rotation.</p>	<p><b>THIS FAR TO GO</b> With hands raised and open inward, move hands laterally, indicating distance to go.</p>
<p>V1065936</p>	<p>V1065937</p>
	<p>V1065938</p>
<p><b>COUNTER ROTATE</b> Place hand on head indicating side or reverse track or wheel rotation. Move other hand in vertical circle indicating forward rotation of other track or wheel.</p>	<p><b>MOVE SLOWLY</b> Place one hand motionless in front of hand giving motion signal. Raise load slowly is shown.</p>
<p>V1065939</p>	<p>V1065940</p>
	<p>V1065941</p>



258 Operating techniques  
Signalling diagram

<p><b>TRAVEL</b> Raise forearm with closed fist indicating inside of turn. Move other fist in vertical circle indicating direction of track or wheel rotation.</p>		<p><b>STOP</b> With either arm extended laterally, hand open downward, move arm back and forth.</p>
<p>V1065942</p>	<p>V1065922</p>	
<p><b>EMERGENCY STOP</b> With both arms extended laterally, hands open downward, wave arms back and forth.</p>	<p><b>STOP ENGINE</b> Draw thumb or forefinger across throat.</p>	



---

## Safety when servicing

This section deals with the safety rules which should be followed when checking and servicing the machine. It also describes the risks when working with unhealthy material and ways to avoid personal injuries.

Further safety rules and warnings texts are given within the respective sections.

### **WARNING**

Risk of burns!

Hot machine parts could cause burns.

**Allow hot machine parts to cool before performing adjustments or service. Wear personal protective equipment.**

## Service position

### NOTE!

Before beginning any service work, the following measures must first be taken.

- 1 Position the machine on even, firm and level ground.
- 2 Put the attachment on the ground.  
Put the dozer blade on the ground if equipped.
- 3 Turn off the engine. After releasing the system and tank pressure, remove the ignition switch.  
See page 332.
- 4 Make sure the control lockout lever is down to lock the system securely, see page 111.
- 5 Pressurized lines and vessels should have the pressure released gradually to avoid risks.
- 6 Allow the machine to cool.

A suitable position is stated in the description for the different service operations. If no particular position is stated, the machine should be parked in service position A.

### Service position A

Retract the bucket and dipper arm cylinder completely, and then lower the boom on the ground.

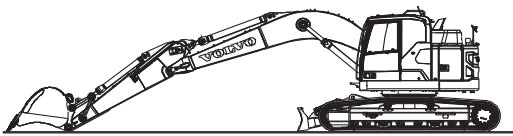

V1151776

### Service position B

Extend the bucket cylinder completely, retract the dipper arm cylinder completely and lower the boom on the ground.

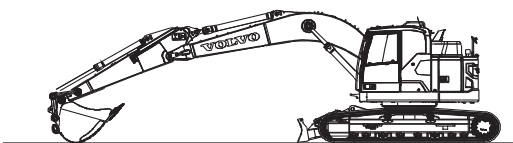

V1151777

## Before service, read

### Preventing personal injury

- Read the Operator's Manual before the service work is started. It is also important to read and follow information and instructions on plates and decals.
- Do not wear loose-fitting clothing or jewellery, which can get caught and cause injury.
- Always wear a hard hat, protective goggles, gloves, protective shoes and other protective articles when the work so requires.
- Make sure that the ventilation is sufficient when starting the engine indoors.
- Do not stand in front of or behind the machine when the engine is running.
- If service work has to be carried out under raised lifting arms, these must first be secured. (Engage the control lever lockout and apply the parking brake if the machine is equipped with one).
- Turn off the engine before opening the rear door and engine cover.
- When the engine is stopped, there is a remaining accumulated pressure in the pressurized systems. If a system is opened without having first released the pressure, liquid under high pressure will jet out.
- When checking for leaks, use paper or hardboard, not your hand.
- Make sure that stepping surfaces, handholds and anti-slip surfaces are free from oil, diesel fuel, dirt and ice. Never step on parts of the machine that are not intended for this.
- It is important to use correct tools and equipment. Broken tools or equipment should be repaired or changed.

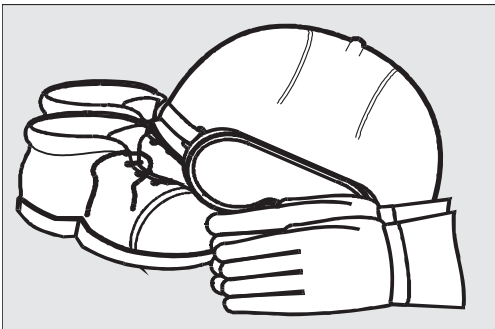

V1065951



### Preventing machine damage

- When lifting or supporting the machine or parts of the machine, use equipment with a sufficient lifting capacity.
- Lifting devices, tools, working methods, lubricants and parts prescribed in the Operator's Manual should be used. Volvo Construction Equipment will not accept any responsibility otherwise.
- Make sure that no tools or other objects, which may cause damage, have been forgotten in or on the machine.
- Release the pressure in the hydraulic system before starting the service work.
- Never set a relief valve to a higher pressure than that recommended by the manufacturer.
- Machines, which are used within a polluted or in another way insanitary area should be equipped for this kind of work. Special safety regulations apply when servicing such a machine.
- When installing two-way radio, mobile telephone or similar equipment, the installation should be carried out in accordance with the manufacturer's instructions in order to eliminate interference with the electronic system and components intended for the function of the machine, see page 23.
- Measures to be taken in connection with electric welding, see page 317.
- Make sure that all covers on the machine are in position before the engine is started and the machine is put to work.





### Preventing environmental influence

Be conscious of the environment when carrying out service and maintenance. Oil and other liquids dangerous to the environment and released into the environment will cause damage. Oil degrades very slowly in water and sediment. One litre of oil can destroy millions of litres of drinking water.

#### **NOTE!**

In common for all points below is that all waste is to be handed over to a treatment and disposal firm approved by the authorities.

- When draining, oils and liquids must be collected in suitable vessels and steps taken to avoid spillage.
- Used filters must be drained of all liquid before they are passed on as waste. Used filters from machines which work in environments with asbestos or other dangerous dust, must be placed in the bag supplied with the new filter.
- Batteries contain substances dangerous to the environment and health. Used batteries must therefore be handled as waste dangerous to the environment.
- Consumables, for example used rags, gloves and bottles may also be contaminated with oils and liquids dangerous to the environment and must in that case be treated as waste dangerous to the environment.

264 Safety when servicing  
Before service, read

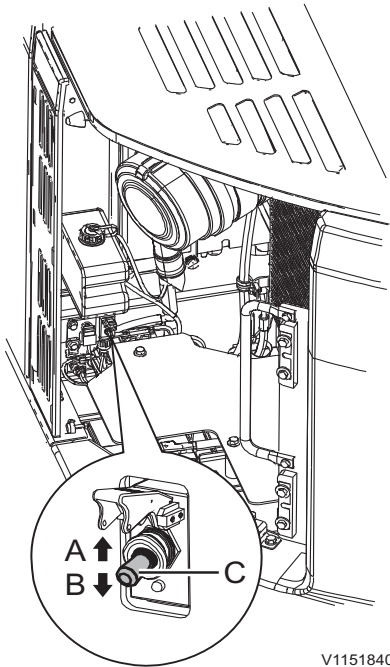

V1151840

- A ON position
- B OFF position
- C Battery disconnect switch

## Battery disconnect switch

### NOTICE

Do not turn off the battery disconnect switch when the engine is running. The electrical system may be damaged.

Battery disconnect switch (C) is located inside the left side door of the machine. When welding, servicing of electrical system or after finishing work of the day for safety, the battery disconnect switch should be turned off.

### NOTE!

Make sure that the indicator light goes out after turning off the battery disconnect switch. This may take a couple of minutes depending on the system status at the time.

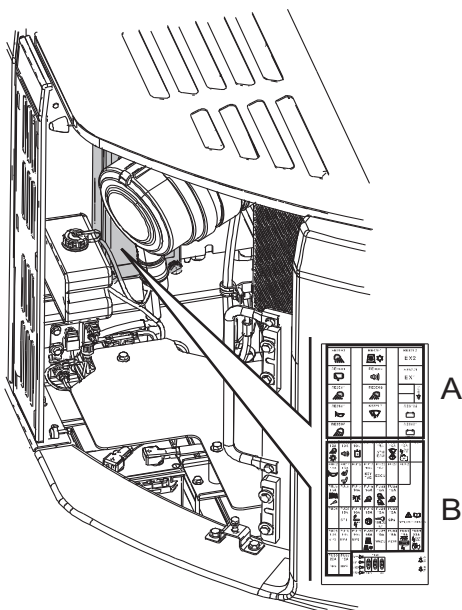

V1151841

## Electrical distribution box

- A Relays
- B Fuses

## Electrical distribution box

Relays and fuses are in the electrical distribution box which is located on the rear side of cab.

### NOTICE

Never install a fuse with a higher amperage than what is stated on the decal. Risk of damage or fire on the circuit board.

Relays and fuses are easily accessible after discovering the cover of box. A decal which shows the exact positions and specifications of respective relays and fuses is provided on the cover, see page 357.

### NOTE!

If a fuse blows repeatedly in the same position, the cause of the fault has to be investigated.



## Hydraulic system

### **NOTICE**

Any work on the hydraulic system requires great demands on cleanliness. Even very small particles can cause damage or clog up the system.

Therefore, wipe areas in question clean before any work is carried out.

The complete hydraulic system including the pressure-limiting valves is set to the correct values from factory.

For any work on the hydraulic system and on pressure-limiting valves the values and tolerances from the Volvo service manual must be applied, otherwise the guarantee from the manufacturer will be void.

Only a qualified service technician is allowed to work on the hydraulic system.



## Hydraulic oil

### NOTE!

Hydraulic oil is hazardous to the environment. Immediately use barriers to contain spilled oil and follow local regulations concerning hazardous materials.

### **NOTICE**

Only hydraulic oil that is approved by Volvo may be used.

### **NOTICE**

Use the same hydraulic oil that is already in the system. The hydraulic system may be damaged if different brands of hydraulic oil are mixed.

### Hydraulic bio oil

- 1 When changing from a mineral oil to a bio oil, the oil must be drained as much as possible and it is required to flush the hydraulic system.
- 2 For the drain points and changing method, please contact the workshop authorized by Volvo Construction Equipment.

## Entering, leaving and climbing the machine

### Entering, leaving and climbing the machine

#### **NOTICE**

The safety regulations and operating instructions issued by the manufacturer must be strictly observed.

- Do not jump on/off a machine, especially never get on / off when the machine moves.
- Never grasp the control lever to get on / off.
- Use handholds and steps when entering, leaving or climbing the machine.
- Use the three-point grip, that is two hands and one foot or two feet and one hand.
- Always face the machine.
- Always wipe mud and oil off all footboards, handrails and your footwear, especially clean the windows, rear view mirrors and lights.
- Clean your boots and wipe your hands before getting on the machine.
- Do not use hand grip (A) of the cab door as a support when entering, leaving and climbing the machine. it is not strong enough to be used as a support. it should only be used for closing the door.

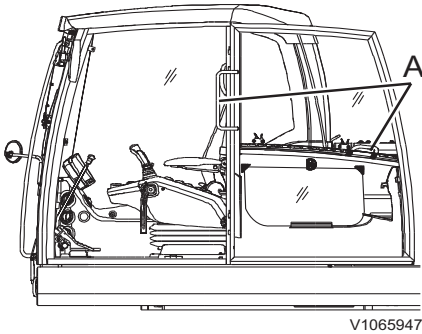

V1065947

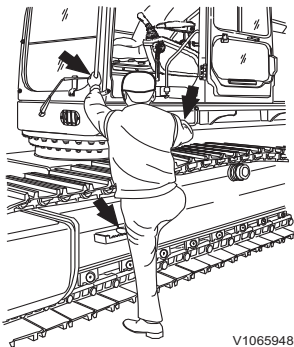

V1065948



## Fire prevention

### NOTE!

Using the machine in environments with high risk of fire or explosion requires special training and equipment.

There is always a risk of fire. Find out what kind of fire extinguisher is used on your working site and how to use it. If the machine is equipped with a fire extinguisher, it should be kept inside the cab on the left side of the operator.

If the machine is to be provided with a hand-held fire extinguisher, it should be of the ABE type (ABC in North America). The designation ABE means that it is possible to extinguish fires in both solid organic material and liquids, and that the fire extinguishing compound does not conduct electricity. Efficiency class I means that the effective operating time of the extinguisher must not be less than 8 seconds, class II at least 11 seconds and grade III at least 15 seconds.

A hand-held fire extinguisher ABE I normally corresponds to a powder content of 4 kg (8.8 lb) (EN-grade 13A89BC), standard EN 3-1995, parts 1, 2, 4 and 5.

### Fire prevention measures

- Do not smoke or have an open flame near a machine when filling with fuel or when the fuel system is opened and in contact with the surrounding air.
- Diesel fuel oil is flammable and must not be used for cleaning. Use conventional car care products meant for cleaning or degreasing. Also bear in mind that certain solvents can cause skin rashes, damage to the paint finish and constitute fire hazard.



## Safety when servicing Fire prevention 269

- Keep the place clean where the service is to be carried out. Oil and water can make the floor slippery and is also dangerous in connection with electrical equipment or electrically powered tools. Oily and greasy clothes are a serious fire hazard.
- Check daily that the machine and the equipment, for example underbelly plates are free from dust and oil. Besides reducing the risk of fire, it is also easier to detect faulty or loose components.

### NOTE!

Take great care if a high-pressure wash is used for cleaning. Electrical components and electrical leads can be damaged even at a moderately high pressure and temperature. Protect electrical leads in an appropriate way.

- Take extra care when cleaning a machine working in a fire-sensitive environment, for example saw-mill and refuse dumps. The risk of spontaneous combustion can be further reduced by installing insulation of the silencer guard.
- It is important that the fire extinguisher is maintained in order to work when it is needed.
- Check that fuel lines, hydraulic and brake hoses and electrical cables have not been damaged by chafing or are not in danger of being damaged in that way because of incorrect installation or clamping. This applies particularly to unfused cables, which are red and marked R (B+) and routed:
  - between the batteries
  - between battery and starter motor
  - between alternator and starter motor

Electrical cables must not lie directly against oil or fuel lines.
- Do not weld or grind on components which are filled with flammable liquids, for example tanks and hydraulic pipes. Exercise care with such work also in the proximity of such places. A fire extinguisher should be kept near to hand.



### **Actions in case of fire**

**If the circumstances permit and your own safety is not jeopardised, take the following steps at the slightest sign of fire:**

- 1 Stop the machine, if the machine is in motion.
- 2 Lower attachments to the ground.
- 3 Move the control lockout lever to locked position, if so equipped.
- 4 Turn the ignition switch to stop position.
- 5 Exit the cab.
- 6 Call the fire brigade.
- 7 If possible to access safely, turn off the battery disconnect switch or emergency stop switch.
- 8 Attempt to put out the fire, if possible. Otherwise, move away from the machine and out of the danger zone.

### **Actions after fire**

**When handling a machine which has been damaged by fire or been exposed to intense heat, the following protective measures must be followed:**

- Use thick, protective gloves made of rubber and wear goggles.
- Never touch burnt components with your bare hands in order to avoid contact with melted polymer materials. First wash thoroughly with plenty of lime water (a solution consisting of calcium hydroxide, that is slaked lime in water).
- Handling heated fluoro-carbon rubber, see page 271.



## Handling hazardous materials

### Heated paint

#### **WARNING**

Risk of toxin inhalation.

Burning of painted, plastic or rubber parts produces gases that could damage respiratory tracts.

**Never burn painted or rubber parts or any plastics.**

Heated paint gives off poisonous gases. Therefore, paint must be removed from an area with a radius of at least 10 cm (4 in) before carrying out welding, grinding or gas cutting. In addition to the health hazard, the weld will be of inferior quality and strength, which, in the future, may cause the weld to break.

#### **Methods and precautionary measures when removing paint**

- **Blasting**
  - use respiratory protective equipment and protective goggles
- **Paint remover or other chemicals**
  - use a portable air extractor, respiratory protective equipment and protective gloves
- **Grinding machine**
  - use a portable air extractor, respiratory protective equipment and protective gloves and goggles

Never burn painted parts after they have been discarded. They should be disposed of by a licensed disposal plant.

#### **Heated rubber and plastics**

Polymer materials can, when heated, form compounds which are dangerous to health and environment and must therefore never be burned when scrapped.

**If gas cutting or welding is to be carried out near such materials, the following safety instructions must be followed:**

- Protect the material from heat.
- Use protective gloves, protective goggles and respiratory protective equipment.

### Heated fluoro-carbon rubber

#### **WARNING**

Risk of serious injury.

At very high temperatures fluoro-carbon rubber forms substances which are very corrosive to skin and lungs.

**Always wear personal protective equipment.**

**When handling a machine which has been damaged by fire or been exposed to intense heat, the following measures should be taken:**

- Use thick, rubber gloves and wear protective goggles.
- Discard gloves, rags and other items that have been in contact with heated fluoro-carbon rubber after first having washed these items in lime water (a solution of calcium hydroxide, that is slaked lime in water).
- The area around a part which has been very hot and which may be made of fluoro-carbon rubber should be decontaminated by thorough and ample washing with lime water.
- As a precaution, all seals (O-rings and other oil seals) should be handled as if they were made of fluoro-carbon rubber.
- The hydrofluoric acid may remain on the machine parts for several years after a fire.
- If swelling, redness or a stinging feeling appears and one suspects that the cause may be contact with heated fluoro-carbon rubber, contact a medical doctor immediately. Several hours may pass, however, before any symptoms appear and there is no immediate warning.
- The acid cannot be rinsed or washed off from the skin. Treat instead with Hydrofluoric Acid Burn Jelly or similar before contacting a medical doctor.



### Crystalline silica (quartz) dust

#### **WARNING**

Risk of hazardous inhalation.

Working in environments containing dangerous dust can lead to serious health problems.

**Wear personal protective equipment when working in dusty environments.**

Crystalline silica is a basis component of sand and granite. Therefore, many activities at construction and mining sites, such as trenching, sawing and boring, produce crystalline silica dust. This dust can cause silicosis.

The employer or working site management should provide the operator with information about the presence of crystalline silica in the work site along with specific work instructions and precautions and also necessary personnel protection equipment. Also check the local / national regulations regarding silica / silicosis.

## Batteries

### **WARNING**

Risk of chemical burns.

The battery electrolyte contains corrosive sulphuric acid which could cause severe chemical burns.

**If electrolyte spilled on your bare skin, remove it immediately and wash the affected area with soap and plenty of water. If it gets into your eyes or any other sensitive body part, rinse with plenty of water and seek immediate medical attention.**

- Do not smoke near batteries as these give off explosive gases.
- Make sure that metal objects, for example tools, rings and watch straps, do not come into contact with the battery pole studs.
- Make sure the protections are always installed over the battery pole studs.
- Do not tilt a battery in any direction. Battery electrolyte may leak out.
- Do not connect a discharged battery in series with a fully charged battery. Risk for explosion.
- When removing a battery, disconnect the ground cable first and when installing, connect the ground cable last in order to reduce the risk of sparks.
- Discarded batteries must be taken care of according to national environmental requirements.
- Charging batteries, see page 316.
- Starting with booster batteries, see page 175.



## Refrigerant

### Environmental precautions

The air conditioning system of the machine is filled with R134a refrigerant at the factory. R134a refrigerant is a fluorinated greenhouse gas and contributes to global warming.

Do not release refrigerant into the environment. See page 361 for the amount of R134a refrigerant in your machine and its global warming potential.

### Safety precautions

Work on the air conditioning system must only be performed by a qualified service technician. Do not attempt to perform work on the air conditioning system.

Wear safety goggles, chemical resistant gloves (e.g., neoprene or butyl rubber) and appropriate personal protective equipment to protect bare skin when there is a risk of contact with refrigerant.

### Actions in case of exposure

**Eye contact:** Rinse with warm water and apply a light bandage. Seek medical attention immediately.

**Limited skin contact:** Rinse with warm water and apply a light bandage. Seek medical attention immediately.

**Extensive skin contact:** Rinse with warm water and carefully heat the area with warm water or warm clothing. Seek medical attention immediately.

**Inhalation:** Leave the area and find fresh air. Seek medical attention immediately.

## Handling line, tubes and hoses

### **WARNING**

Risk of high pressure injection.

Oil or fuel leaks from high pressure hoses could cause serious injury caused by high pressure injection.

**If oil or fuel leaks from high pressure hoses or loose screws are found, stop operations immediately and contact a qualified service technician.**

- Do not bend high pressure lines.
- Do not strike high pressure lines.
- Do not install any lines that are bent or damaged.
- Check lines, tubes and hoses carefully. (leakage, damage, deformity and aging)
- Do not reuse hose, tube and fittings.
- Do not use your bare hand to check for leaks.
- Tighten all connections. Consult your Volvo Construction Equipment dealer for the recommended tightening torque.

If any of the following conditions are found, replace the parts. Consult your Volvo Construction Equipment dealer.

- Connections and end fittings are damaged, leaking, deformed or aged.
- Outer coverings are chafed or cut.
- Strengthening wires are exposed.
- Outer coverings are ballooning.
- Flexible part of the hoses are kinked.
- End fittings are displaced.
- Foreign material is embedded in the coverings.

### **NOTICE**

**Make sure that all clamps, guards and heat shields are correctly installed. This contributes to preventing vibrations, chafing against other parts and excessively strong generation of heat.**



V1068256

## Maintenance

If the machine is to function satisfactorily and at lowest possible cost, it requires careful maintenance.

Regarding intervals for other maintenance, see the "Service Programme" or the "Lubrication and Service Chart" in this chapter.

### Lubrication and service chart

The section "Lubrication and service chart" describes the maintenance work which the operator can carry out. If certain operations require trained workshop personnel and special equipment, this will be indicated.

### Service history

After each completed service by a qualified service technician, the service history should be filled in, see page 394. Service history is a valuable document, which is referred to when selling the machine.

### Arrival Inspection

Before the machine leaves the factory, it is tested and adjusted. The dealer or distributor must also carry out arrival inspections according to the applicable form.

### Delivery Inspection

Before the machine leaves the factory, it is tested and adjusted. The dealer or distributor must also carry out delivery inspections according to the applicable form.

### Delivery Instructions

When handing the machine over, the dealer must give the buyer "Delivery instructions" according to



applicable form, which must be signed, if the warranty is to apply.

## Service Programme

For any factory warranty to be valid, the machine shall be maintained according to the service program established by Volvo. The service program is continuous with fixed intervals. The operating time between intervals only applies if the machine is used in normal environment and operating conditions. Ask your Volvo dealer what is right for your specific machine.





---

## Lubrication and service chart

### Lubrication

Lubrication is an important part of preventive maintenance. The service life of bushings, bearings and bearing pins can be extended considerably if the machine is lubricated in a correct way. A lubrication chart makes lubrication work easier and reduces the risk of forgetting greasing points.

**Lubrication has two main purposes:**

- To supply grease to the bearing in order to reduce wear between the pin and the bearing.
- To replace old and dirty grease. The grease stored inside the outer seal collects dirt and water and prevents them from penetrating into the bearing.

### **NOTICE**











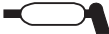



Wipe off grease nipples and grease gun before greasing, so that dirt and sand are not introduced through the grease nipples into the bearings.

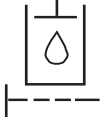
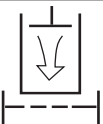

280 Maintenance  
Lubrication and service chart

**Symbol key**

These standard symbols are used in the Lubrication and service chart, see the adjacent table.

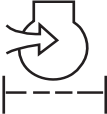
 1 Engine oil	 2 Grease lubrication	 3 Swing drive gear oil change
 4 Swing drive gear oil check	 5 Track drive gear oil check	 6 Track drive gear oil change
 7 Hydraulic oil	 8 Hydraulic oil level	 9 Hydraulic oil filter
 10 Hydraulic tank, air breather filter	 11 Fuel filter	 12 Water separator
 13 Engine, coolant	 14 Engine, coolant filter	 15 Engine coolant level
 16 Engine oil level	 17 Engine oil filter	 18 Operator manual
 19 Air cleaner filter		

### Lubrication and service chart

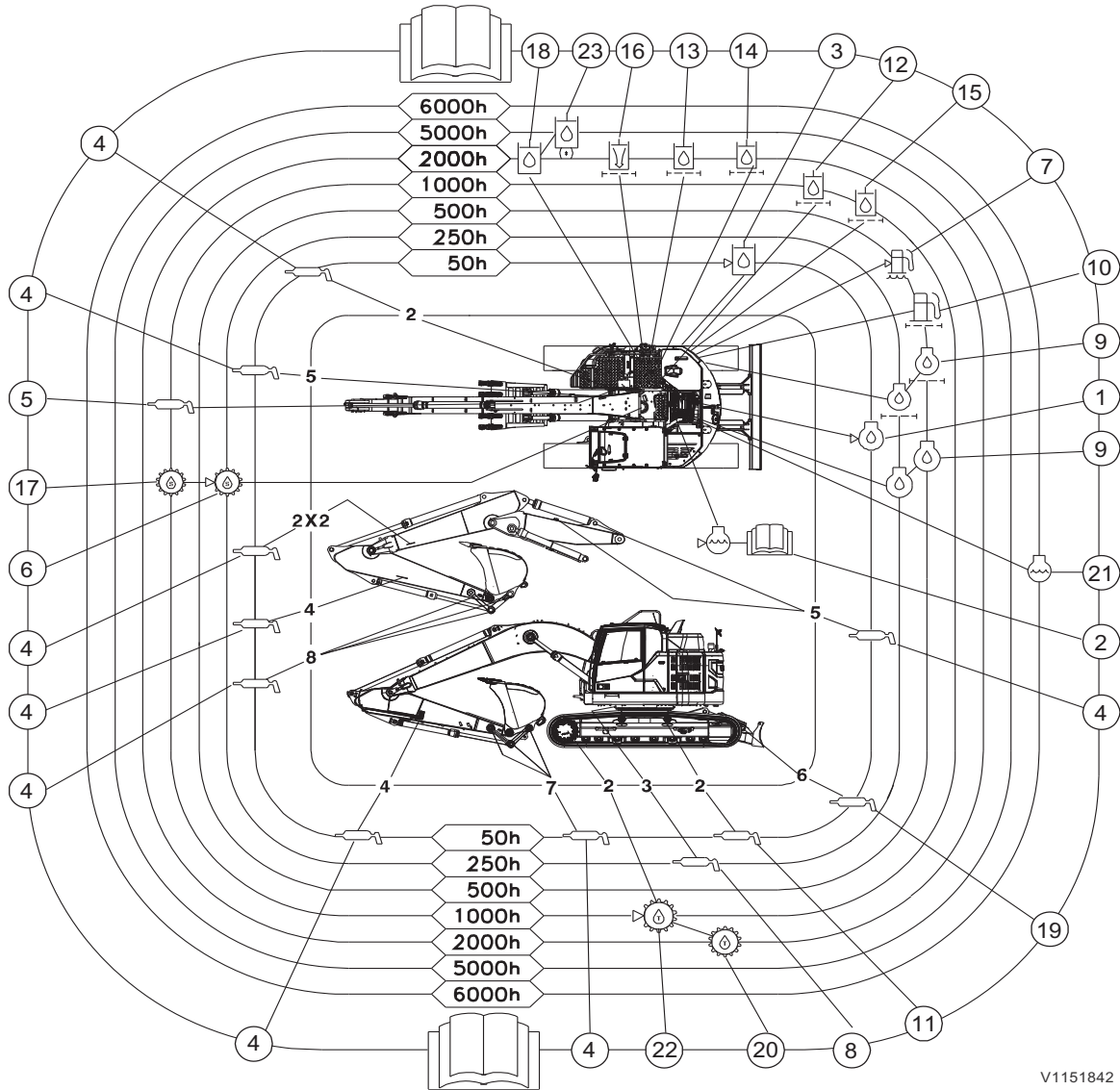



**282**      **Maintenance**  
**Lubrication and service chart**

When required	Item	Page
Check the coolant level <sup>(1)</sup>	2	325
Check and drain the water separator <sup>(1)</sup>	-	314
Drain the sediment from fuel tank	Workshop job <sup>(2)</sup>	-
Clean the primary filter of air cleaner <sup>(1)</sup>	-	321

<b>DAILY (every 10 hours)</b>	Item	Page
Check the track shoe screws	-	287
Check the washer fluid level	-	288

<b>Every 50 hours</b>	Item	Page
Check the engine oil level, or <sup>(1)</sup>	1	289
Check the hydraulic oil level	3	290
Check the track tension	11	292
Lubricate attachments	4	294
Lubricate dozer blade unit	19	

<b>Every 250 hours after carrying out Daily and 50 hours services</b>	Item	Page
Check the oil level of swing drive unit	6	297
Clean the prefilter of air conditioner Clean the main filter of air conditioner	-	298
Lubricate the swing gear bearing	8	298

1. Check according to the signal on IC (Instrument Cluster)  
2. Contact a workshop authorized by Volvo



Maintenance  
**Lubrication and service chart**     **283**

Every 500 hours after carrying out Daily, 50 and 250 hours services	Item	Page
Perform the parked service regeneration to reset EATS before changing the engine oil	Workshop job <sup>(1)</sup> (2)	-
Change the engine oil <sup>(3)</sup> and oil filter	9 Workshop job <sup>(2)</sup>	-
Change the fuel filter	10 Workshop job <sup>(2)</sup>	-
Change the water separator filter element	7 Workshop job <sup>(2)</sup>	-
Clean the radiator, oil cooler and condenser fins <sup>(4)</sup>	-	<i>300</i>
Check the battery condition	-	<i>302</i>
Check the belt tension for air conditioning (Initial interval : 100 hours)	Workshop job <sup>(2)</sup>	-

- 
1. Volvo's service tool is required
  2. Contact a workshop authorized by Volvo
  3. Or at least once a year
  4. Or when required



**284**      Maintenance  
Lubrication and service chart

Every 1000 hours after carrying out Daily, 50, 250 and 500 hours services	Item	Page
Check the oil level of track drive unit	22	304
Check the swing bath grease	5	304
Check the overload warning system	-	304
Change the hydraulic servo filter <sup>(1)</sup>	12 Workshop job <sup>(2)</sup>	-
Change the hydraulic oil drain filter <sup>(1)</sup>	15 Workshop job <sup>(2)</sup>	-
Change the oil of swing drive unit <sup>(1)</sup>	17 Workshop job <sup>(2)</sup>	-
Check the belt tension for alternator	Workshop job <sup>(2)</sup>	-
Check the software update <sup>(3)</sup>	Workshop job <sup>(2)</sup>	-

- 
1. First change: 500 hours
  2. Contact a workshop authorized by Volvo
  3. At least once a year



Maintenance  
Lubrication and service chart **285**

Every 2000 hours after carrying out Daily, 50, 250, 500 and 1000 hours services	Item	Page
Check the coolant content <sup>(1)</sup>	Workshop job <sup>(3)</sup>	307
Clean the suction strainer of hydraulic tank <sup>(2)</sup>	13 Workshop job <sup>(3)</sup>	-
Change the primary filter of air cleaner <sup>(4)</sup>	-	306
Change the air breather filter on hydraulic tank	16 Workshop job <sup>(3)</sup>	-
Change the air ventilation filter on fuel tank	Workshop job <sup>(3)</sup>	-
Change the oil of track drive unit <sup>(5)</sup>	20 Workshop job <sup>(3)</sup>	-
Change the hydraulic oil (mineral oil) <b>If Hydraulic Breaker (hammer) is equipped, change the hydraulic oil according to frequency of HB use</b> - Frequency of HB use (50%): every 1000 hours - Frequency of HB use (100%): every 600 hours	18 Workshop job <sup>(3)</sup>	-
Change the prefilter of air conditioner Change the main filter of air conditioner	-	306
Change the hydraulic oil return filter <sup>(5)</sup> <b>If Hydraulic Breaker (hammer) is equipped, change the hydraulic return filter according to frequency of HB use</b> - Frequency of HB use (50%): every 1000 hours - Frequency of HB use (100%): every 500 hours	14 Workshop job <sup>(3)</sup>	-
Check the valve clearance	Workshop job <sup>(3)</sup>	-

1. Or every year
2. Or when required
3. Contact a workshop authorized by Volvo
4. At least once a year
5. First change: 500 hours



**286**      **Maintenance**  
**Lubrication and service chart**

Every 4000 hours after carrying out Daily, 50, 250, 500, 1000 and 2000 hours services	Item	Page
Change the secondary filter every 3rd time primary filter is replaced <sup>(1)</sup>	-	309
Change the CareTrack backup battery (at least every 3 years)	Workshop job <sup>(2)</sup>	-

Every 5000 hours after carrying out Daily, 50, 250, 500, 1000, 2000 and 4000 hours services	Item	Page
Change the hydraulic oil (bio oil and long life hydraulic oil) <b>If Hydraulic Breaker (hammer) is equipped, change the hydraulic oil according to frequency of HB use</b> - Frequency of HB use (50%): every 1000 hours - Frequency of HB use (100%): every 600 hours	23 Workshop job <sup>(2)</sup>	-

Every 6000 hours after carrying out Daily, 50, 250, 500, 1000, 2000, 4000 and 5000 hours services	Item	Page
Change the coolant <sup>(3)</sup>	21 Workshop job <sup>(2)</sup>	-
Change the AdBlue®/DEF pump unit filter	Workshop job <sup>(2)</sup>	-
Change the air breather filter on AdBlue®/DEF tank	Workshop job <sup>(2)</sup>	-

Every 8000 hours after carrying out Daily, 50, 250, 500, 1000, 2000, 4000, 5000 and 6000 hours services	Item	Page
Clean the diesel particulate filter	Workshop job <sup>(2)</sup>	-

1. Or at least every 2 years  
2. Contact a workshop authorized by Volvo  
3. Or at least every 4 years



## Maintenance service, every 10 hours

### Track unit, checking shoe screws

Check the shoe screws daily.

If track shoe screws (A) are loose, the track shoes are likely to be damaged.

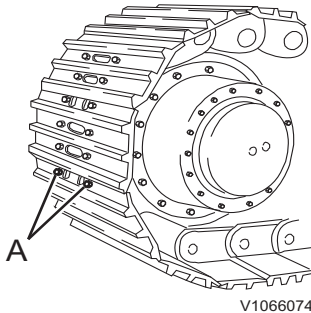

A Shoe screw

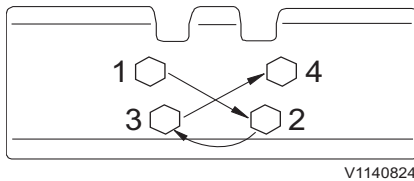

Order to tighten the screws

- 1 Swing the superstructure to the side and raise the track using boom down operation.
- 2 Turn the track slowly in forward and reverse direction several time. Check for missing, loose or damaged shoe screws and shoes. If needed, tighten the screws to specified torque,  $85 \pm 5 \text{ kgf m}$  ( $834 \pm 49 \text{ N m}$ ) ( $614 \pm 36 \text{ lbf ft}$ )

### **NOTICE**

It is very important that loose track shoe screws and nuts are removed fully and that the threads are cleaned. Clean the track shoes before they are installed and the screws tightened.

- 3 After tightening, check whether the nut and the shoe are in full contact with the mating surfaces of the link.

Tighten the screws in the order as shown in the figure.

288 Maintenance  
Maintenance service, every 10 hours

---

### Washer reservoir

Check the fluid level daily.

**NOTE!**

When the temperature is below freezing point, anti-freeze should be added to the washer fluid. Follow the manufacturer's recommendations as regards the ambient temperature.

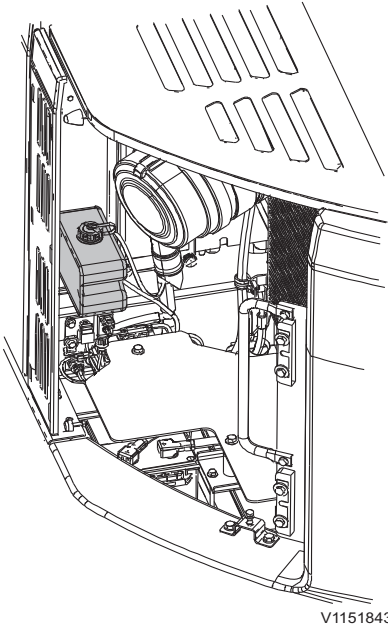

Washer reservoir

### Excavator unit, greasing

Grease the excavator unit every 10 hours or daily only during first 100 hours.

After first 100 hours of operation, grease the excavator unit every 50 hours or weekly.

See page 294.

## Maintenance service, every 50 hours

### Engine oil level, checking

#### WARNING

Risk of serious injury.

Rotating parts could cause serious cutting or crushing injury.

**Never open the engine hood when the engine is running.**

Check the oil level when the check screen for low engine oil level pops up in the front instrument panel, see page 44. Aside from this, check the oil level every 50 hours.

#### NOTE!

Check the oil level when the machine has cooled down. (at least 30 minutes after turning off the engine)

- 1 Position the machine on even, firm and level ground.
- 2 Open the engine hood.
- 3 Pull out dipstick (A) and wipe it with a clean cloth.
- 4 Push it in and pull it out again.
- 5 If the oil level is between (C) and (D), it is normal. If the oil level is below (D), refill the oil to proper level through filler port (B). For the recommended engine oil, see page 338.

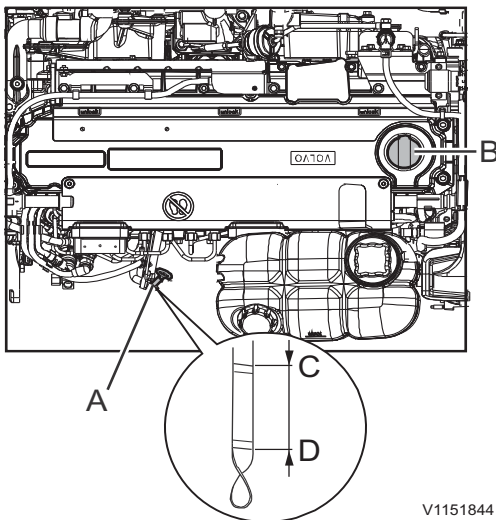

V1151844

- A Dipstick
- B Filler port
- C Oil level, High
- D Oil level, Low

290 Maintenance  
Maintenance service, every 50 hours

## Hydraulic oil level, checking

Check the oil level every 50 hours.

- 1 Park the machine in service position B, see page 260.
- 2 Move the control lockout lever down to lock the system securely and stop the engine.
- 3 Check the oil level in the sight gauge. If the level is in the center of the gauge, the level is correct.

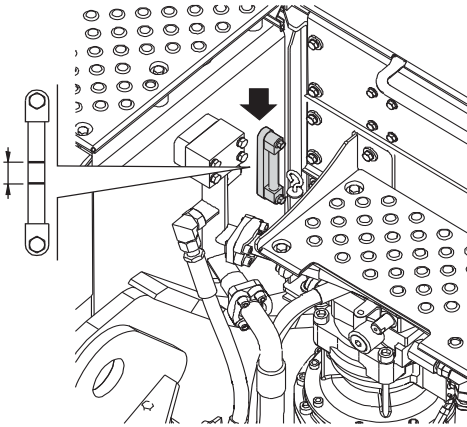

V1110238

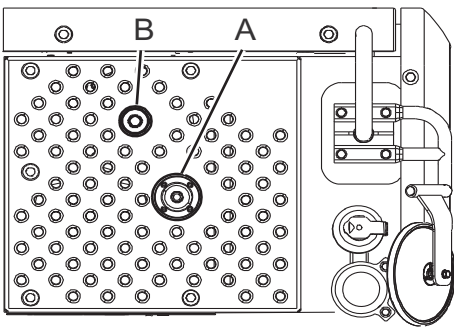

V1110239

- 4 If the level is low,
  - Press breather (A) to release the internal pressure at the tank.
  - Remove filling plug (B) and top up with hydraulic oil.

### NOTE!

To top up the oil efficiently press air breather again.

- Check the level.
- If the level is normal, install the filling plug.

### NOTICE

Use the same hydraulic oil that is already in the system. The hydraulic system may be damaged if different brands of hydraulic oil are mixed.

Maintenance

Maintenance service, every 50 hours 291

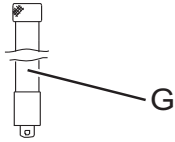
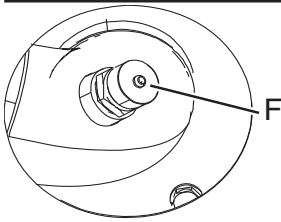

V1141845

- 5 If the level is high,
  - Place a suitable sized container under the hydraulic tank.
  - Remove the protecting cap (F) and attach drain hose (G).
  - Drain the oil into a container.

**NOTICE**

Take care of filters, oils and liquids in an environmentally safe way.

- Disconnect the drain hose and install the protecting cap.

## Track unit, checking tension

Check the track tension every 50 hours.

### WARNING

Risk of crushing.

Raised equipment may drop if the hydraulic system fails or if the control is operated. Falling equipment may cause serious injury or death.

**Always make sure that raised equipment is supported by a mechanical device before walking or working under it.**

### NOTE!

To check the track tension, the track must be raised off the ground.

When two persons are working, the operator should follow the sign of the maintenance worker.

The degree of wear condition of track link pins and bushings varies with the working condition or the characteristics of soil. Check the track tension often and keep it to the specified value.

When working in wet sand or clay, it sticks to and packs between moving undercarriage components. This can prevent mating parts from properly engaging each other, which cause interference and high loads. Due to abrasive particles in the material it significantly accelerates wear rates of the sprockets, pins / bushings, idlers and track links as the track load and tension increase. Generally, packing effects cannot be controlled except by constant cleaning or removal of the material.

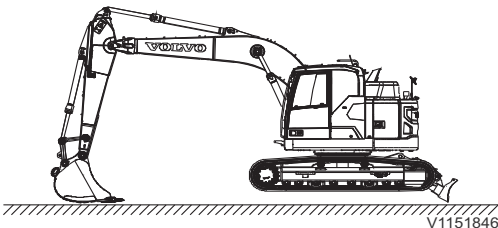

Maintenance  
**Maintenance service, every 50 hours 293**

Therefore thoroughly clean the undercarriage at least daily or more often according to soil conditions in job-site.

- 1 Swing the superstructure to the side and raise the track by using boom and dipper arm. For this movement, operate the lever slowly.
- 2 Turn the track slowly in forward and reverse direction several time. Stop the track while moving in the reverse direction.
- 3 Measure the track slack (L) at the center of track frame, the clearance between the bottom of track frame and the upper surface of track shoe.
- 4 Adjust the track tension according to the soil characteristics.

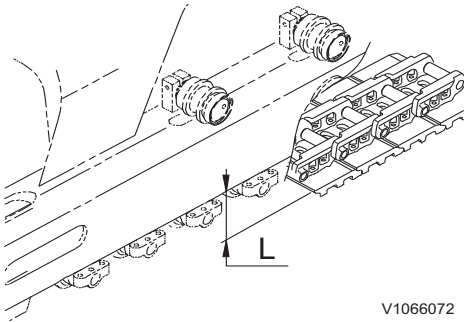

V1066072

Recommended track tension is as below,

Working condition	Clearance ( L ) (mm) (in)
General soil	320 - 340 (12.6 - 13.4)
Rocky ground	300 - 320 (11.8 - 12.6)
Moderate soil like gravel, sand, snow, and so on.	340 - 360 (13.4 - 14.2)



## Excavator unit, greasing

### With normal bush

Grease the excavator unit every 50 hours or weekly.

During the first 100 hours, the excavator unit should be greased every 10 hours or daily.

### NOTE!

Under severe operating conditions where mud, water, and abrasive material may enter the bearings, or after using the hydraulic hammer, the excavator unit should be greased every 10 hours or daily.

When greasing by hand, lower the attachment to the ground as illustrated, and stop the engine. Grease through the grease nipples using a hand or power grease gun. After greasing, clean off the superfluous grease.

Immediately after working under water, grease the submerged parts such as the bucket pins to remove the old grease, regardless of the grease interval. For grease specification, see page 338.



Maintenance  
Maintenance service, every 50 hours 295

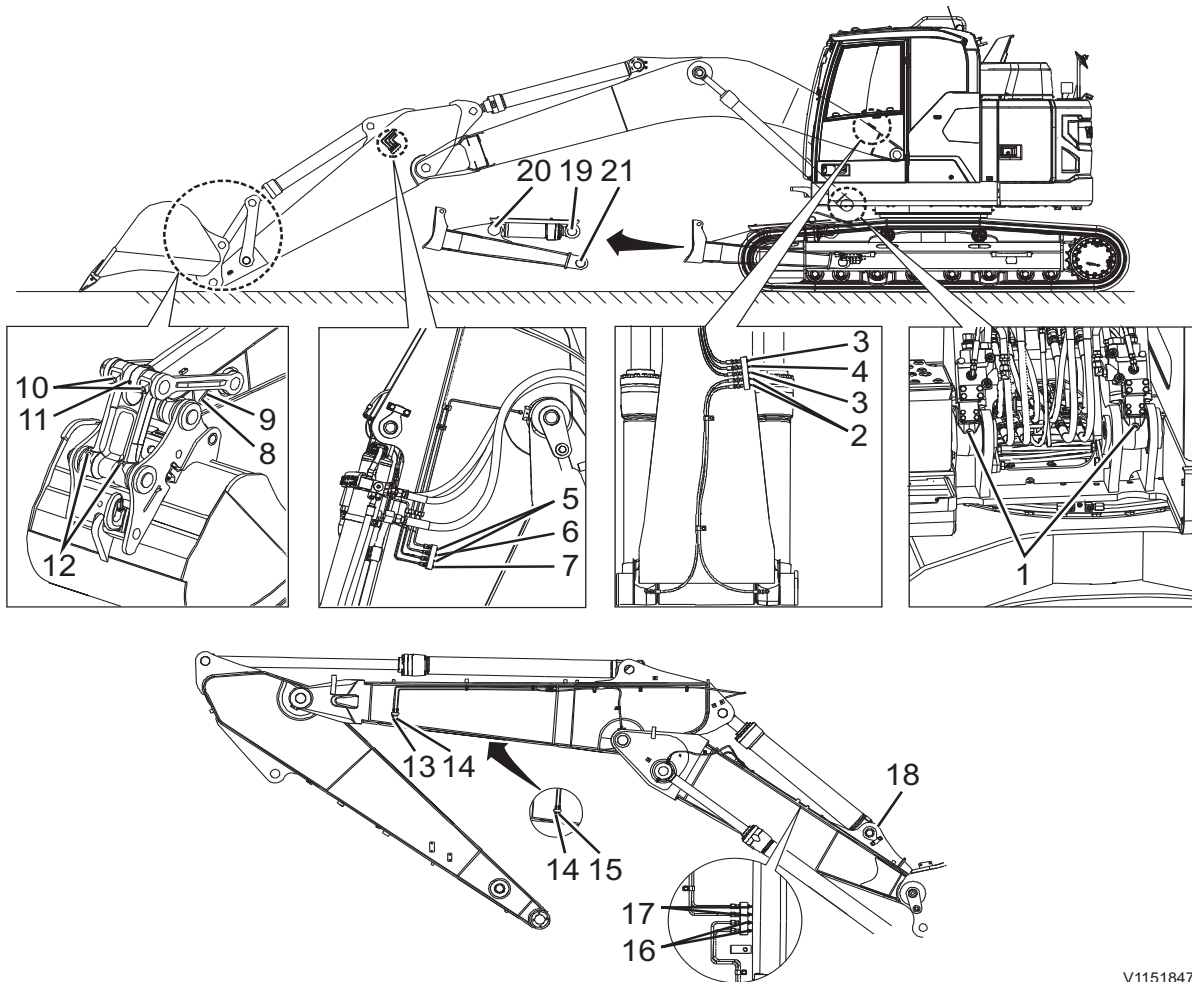

V1151847

- |   |   |
|---|---|
| 1 Boom cylinder mounting pin (2 points)           | 12 Pin between bucket and connecting rod (2 points) |
| 2 Boom mounting pin (2 points)                    | 13 Second boom cylinder rod end pin (1 point)       |
| 3 Boom cylinder rod end pin (2 points)            | 14 Pin between boom and second boom (2 points)      |
| 4 Dipper arm cylinder mounting pin (1 point)      | 15 Dipper arm cylinder mounting pin (1 point)       |
| 5 Pin between boom and dipper arm (2 points)      | 16 Boom mounting pin (2 points)                     |
| 6 Dipper arm cylinder rod end pin (1 point)       | 17 Boom cylinder rod end pin (2 points)             |
| 7 Bucket cylinder mounting pin (1 point)          | 18 Second boom cylinder mounting pin (1 point)      |
| 8 Pin between dipper arm and bucket (1 point)     | 19 Dozer blade cylinder rod end pin (2 points)      |
| 9 Pin between dipper arm and link (1 point)       | 20 Dozer blade cylinder mounting pin (2 points)     |
| 10 Pin between connecting rod and link (2 points) | 21 Dozer blade mounting pin (2 points)              |
| 11 Bucket cylinder rod end pin (1 point)          |   |

## Maintenance service, every 250 hours

### Swing drive unit

#### **NOTICE**

Always clean around the oil dipstick before you check the oil level. Dirt in the oil damages the swing gearbox.

It is very important that the oil level is always correct and that it is checked at working temperature.

- **Too little oil** may lead to insufficient lubrication of the swing drive unit and cause costly damage.
- **Too much oil** may lead to oil foaming, and cause the swing drive unit to overheat.



#### **WARNING**

Risk of burns!

Hot liquids and machine parts can cause burns.

**Allow the machine to cool before beginning any service.**

## Swing drive unit, checking oil level

Check the oil level every 250 hours.

- 1 Pull out oil dipstick (A) and wipe it with a clean cloth.
- 2 Insert oil dipstick and pull it out again.
- 3 Check the oil level. If the level is in the center of "D", the level is correct.
- 4 If the level is low, top up oil through oil filler hole (B) to correct level.
- 5 If the level is high,
  - Remove the under cover (C).
  - Place a suitable sized container under the drain valve (E).
  - Open the protection cap of drain valve (E).
  - Attach the drain hose (F) and drain the oil to the correct level.
  - Disconnect the drain hose.
  - Close the protecting cap.

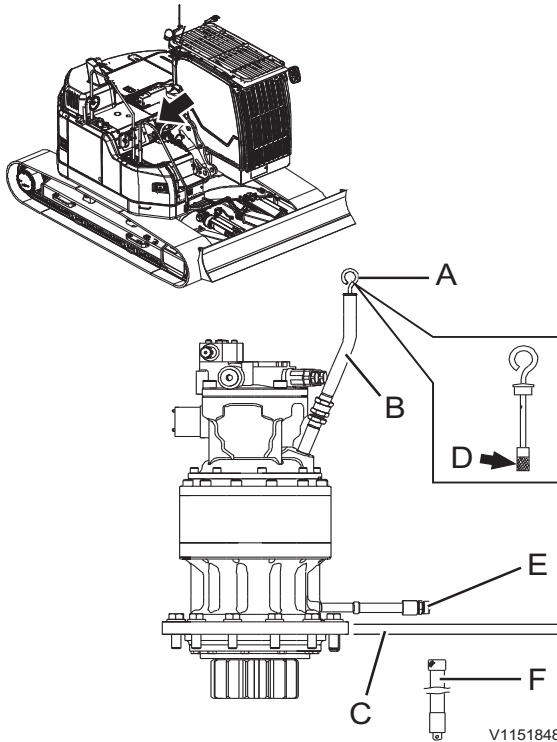

For oil specification, see page 338.

298 Maintenance  
Maintenance service, every 250 hours

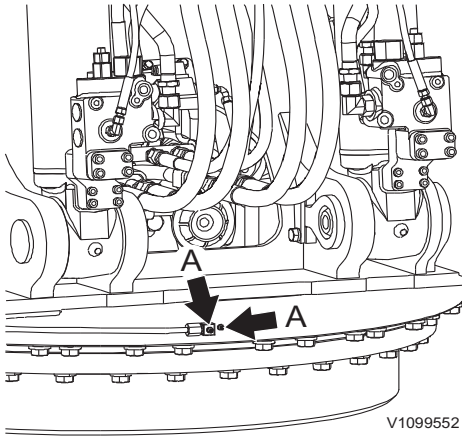

### Swing gear bearing, greasing

Grease the swing gear every 250 hours.

- 1 Park the machine on level ground.
- 2 Lower the bucket to the ground.
- 3 Move the control lockout lever down to lock the hydraulic system securely and stop the engine. See page 111.
- 4 Fill the grease in the grease nipples (A) using a hand or power grease gun.
- 5 Apply grease to the swing bearing until grease can be seen from the swing bearing seals.
- 6 Take care not to supply excessive amount of grease.
- 7 After greasing, clean off the superfluous grease completely.

### Air conditioning filter, cleaning and replacing

If the air conditioner filter is clogged, the air flow as well as the cooling and heating capacity will be reduced. Therefore, clean it periodically.

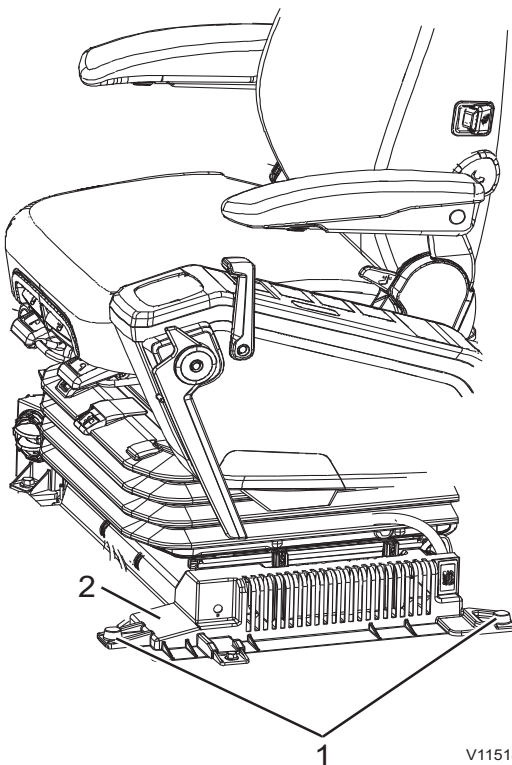

#### **WARNING**

Risk of hazardous inhalation.

Dangerous dust can lead to serious health problems.

**Always wear personal protective equipment, including filter mask, eye protection and appropriate gloves when handling and cleaning the engine compartment, coolers and air filters.**

#### **NOTE!**

If the machine is operated in particularly dusty environment or in air with hazardous material to human such as asbestos, special filter should be used. Please contact Volvo Construction Equipment dealer for more information.

#### **NOTICE**

Refrigerant R134a adds to the greenhouse effect and may not be released.

Clean the prefilter and main filter every 250 hours. Replace the prefilter and main filter every 2000 hours.

Maintenance  
Maintenance service, every 250 hours 299

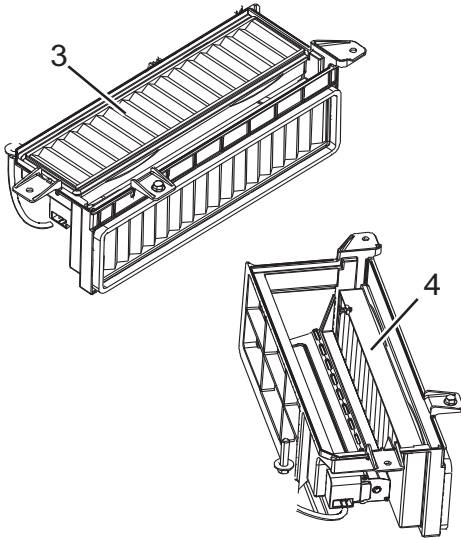

V1152269

- 1 Remove screws (1) and cover (2).
- 2 Take out main filter (3) and clean it with compressed air.
- 3 Take out prefilter (4) and clean it with compressed air.
- 4 Install the filters, and assemble them in reverse order.

**NOTE!**

Clean the filter with compressed air with a maximum pressure of 0.2 Mpa (30 psi).

**NOTE!**

If the filter is damaged or heavily contaminated, replace it with a new one.

## Maintenance service, every 500 hours

### Radiator and coolers, cleaning

Cleaning interval depends on the environmental condition the machine is operating. Therefore, clean all fins when required or at least every 500 hours.

#### **WARNING**

Risk of hazardous inhalation.

Dangerous dust can lead to serious health problems.

**Always wear personal protective equipment, including filter mask, eye protection and appropriate gloves when handling and cleaning the engine compartment, coolers and air filters.**

#### **WARNING**

Risk of serious injury.

Compressed air, water jets or steam may cause damage to unprotected skin and eyes.

**Always wear personal protective gloves, goggles and clothing when using compressed air, water jets or steam.**

#### **NOTICE**

**DO NOT use steam to clean the condenser core. The refrigerant can overheat! When cleaning with water, protect the electrical components.**

If the engine temperature becomes too high even though the coolant level is correct, the radiator should be cleaned.

Maintenance  
Maintenance service, every 500 hours **301**

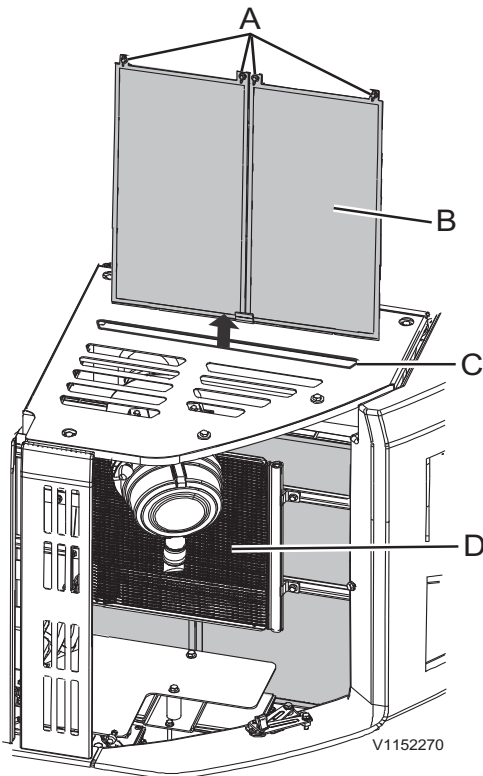

- A Wing nuts
- B Radiator screen
- C Hole
- D Condenser

- 1 Open the left side door of the machine.
- 2 Remove the leaves attached to condenser (D).
- 3 Remove wing nuts (A).
- 4 Pull out radiator screen (B) through hole (C).
- 5 Clean the radiator screen.
- 6 Clean any mud, dust or leaves attached to the radiator fins and oil cooler fins with compressed air or steam.
- 7 Check the rubber hose for wear and cracks. If damaged, replace it. Check the hose clamp for looseness.
- 8 Reinstall the screen with the wing nuts.

**NOTICE**

When using compressed air, keep the nozzle at a distance from the fins to prevent damage. Damaged fins may cause leakage or overheating.

If the engine temperature still remains high after cleaning the cooler, contact a workshop authorized by Volvo for remedial action.

302 Maintenance  
Maintenance service, every 500 hours

### Battery condition, check

**NOTE!**

This type of battery is maintenance free (MF) so it is not possible to check the electrolyte level, only a battery condition check is available.

- 1 Ensure the battery disconnect switch is at off position and remove the battery cover.
- 2 Check the condition of battery through indicator (B) according to guidance on battery decal (A).

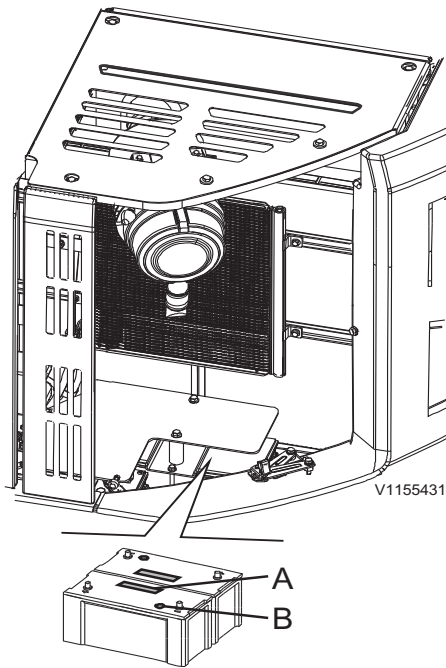

A Battery decal  
B Indicator

Indicator color	
Green	Normal
Black	Need charging
White	Need checking



## Maintenance service, every 1000 hours

### Track drive unit

#### **NOTICE**

Always clean around the level plug before you check the oil level. Dirt in the oil damages the track gearbox.

It is very important that the oil level is always correct and that it is checked at working temperature.

- **Too little oil** may lead to insufficient lubrication of the track drive unit and cause costly damaged.
- **Too much oil** makes the oil foaming and cause the track drive unit to overheat.

#### **WARNING**

Risk of burns!

Hot liquids and machine parts can cause burns. **Allow the machine to cool before beginning any service.**

#### **WARNING**

Risk of high pressure injection.

Residual pressure in the hydraulic system could lead to oil under high pressure jetting out and cause serious injury, even if the engine has not been running for some time.

**Always release the pressure before any kind of service of the hydraulic system is carried out.**

304 Maintenance  
Maintenance service, every 1000 hours

### Track drive unit, checking oil level

Check the oil level every 1000 hours.

- 1 Turn the case so that drain plug (A) is located at the bottom.
- 2 Remove the level checking plug (B). If the oil is about to overflow from the hole, the level is correct.

If the oil is low, top up the oil to the correct level through the plug (B).

For oil specification, see page 338.

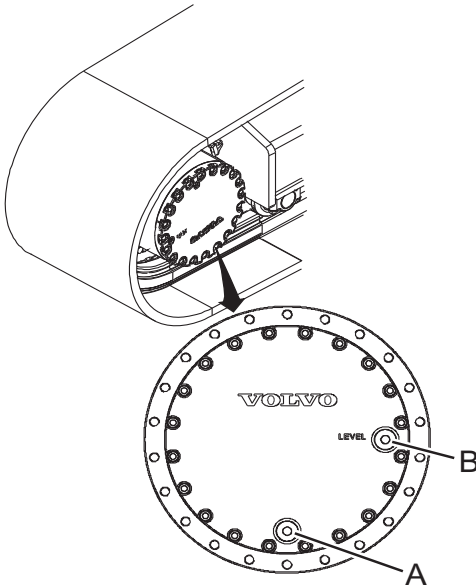

V1152271

### Swing bath, grease checking

Check the grease condition and level every 1000 hours.

- 1 Park the machine on a level ground and move the superstructure as shown in the figure.
- 2 Lower the bucket to the ground.
- 3 Turn the ignition switch to stop position.
- 4 Move the control lockout lever down to lock the system securely. See page 111.
- 5 Remove screws (B) and the cover (C).
- 6 Check the level and condition of the grease. Fill if needed.
- 7 Inspect the seal (D). Replace the seal if damaged.
- 8 Install the cover.

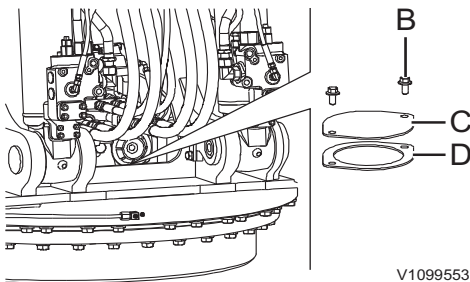

V1099553

#### NOTE!

If the grease is contaminated or discoloured with water, contact a workshop authorized by Volvo for changing the grease.

### Overload warning

Check the overload warning system every 1000 hours according to below procedure.

- 1 Place the machine on level and firm ground.



Maintenance

---

**Maintenance service, every 1000 hours      305**

- 2 Engage the overload warning with the button on the keypad, see page *80*.
- 3 Operate the boom cylinders to their upper end positions.  
The overload warning signal should sound and the overload symbol should appear in the IC (Instrument Cluster). If not contact a qualified service technician.



306 Maintenance  
Maintenance service, every 2000 hours

---

**Maintenance service, every  
2000 hours**

**Engine air cleaner primary filter,  
replacing**

See page *321*.

**Air conditioning filter, cleaning and  
replacing**

See page *298*.

## Coolant

### **NOTICE**

If the warning of high coolant temperature is shown on the display unit, the engine must be stopped immediately.

Check the coolant contents (%) every 2000 hours or every 1 year.

The cooling system is filled with Volvo Coolant VCS, which fulfils the highest requirements regarding freeze-, corrosion-, and cavitation protection. To avoid damage to the engine, it is very important that Volvo Coolant VCS is used when filling or changing the coolant.

Volvo Coolant VCS is yellow and a decal by the filling point shows that the system is filled with this coolant (see picture).



V1066019

### **NOTICE**

Volvo Coolant VCS must never be mixed with any other coolant or corrosion protection to avoid damage to the engine.

The cooling system capacity when changing, see page 353.

If concentrated Volvo Coolant VCS and clean water (see page 342) is used, the table below shows the approximate amount of concentrated coolant needed for freezing protection. The content of Volvo Coolant VCS must never be less than 40% of the total mixture.



308 Maintenance  
Maintenance service, every 2000 hours

---

If in doubt of the water's quality, use the ready-mixed Volvo Coolant VCS, which contains 40% concentrated coolant.

**NOTICE**

In order to avoid damage to engine and cooling system, different brands of coolant or corrosion protection must not be mixed.

Freeze protection down to	Content of concentrated coolant
-25 °C (-13 °F)	40%
-35 °C (-31 °F)	50%
-46 °C (-51 °F)	60%



	Maintenance	
Maintenance service, every 4000 hours		309

---

## Maintenance service, every 4000 hours

Engine air cleaner secondary filter, replacing

See page 324.

310 Maintenance  
Maintenance service, when required

## Maintenance service, when required

### Engine oil level, checking

See page 289.

### Fuel, filling

#### **! WARNING**

Risk of fire.  
Burning fuel can cause fatal injuries.  
**Stop the engine before filling fuel.**

#### **! WARNING**

Risk of fire and explosion.  
A running auxiliary heater during fuel filling could cause fire and explosion.  
**Switch off the auxiliary heater before filling fuel.**

#### **NOTICE**

Risk of fuel tank contamination.  
**Accidental filling of AdBlue®/DEF in to the fuel tank causes fuel tank contamination.**  
Only use AdBlue®/DEF filling equipment that has a valve that opens only on machines equipped with a magnetic ring in the AdBlue®/DEF filler neck to avoid fuel tank contamination.

- 1 Carefully clean around the filler cap on the fuel tank before removing it.
- 2 Open the fuel filler cap (A) and fill the fuel in the tank.
- 3 Check the fuel level on IC (Instrument Cluster).  
See page 38.

Avoid spilling the fuel when filling, which attracts dirt. If fuel is spilled, clean it up immediately.  
During the cold season, fill up the fuel tank to prevent water condensing in the tank.

**For the capacity of fuel tank, see page 353.**

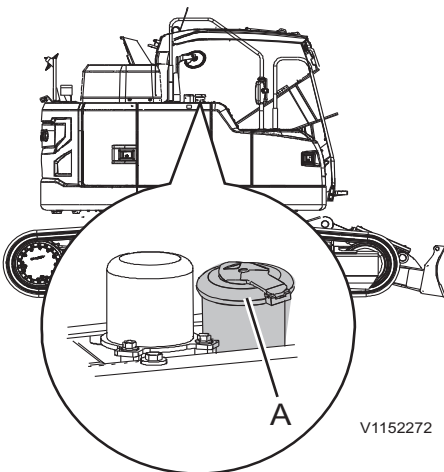

A Fuel filler cap



Maintenance  
Maintenance service, when required 311

Filling with auto shut-off controller (optional equipment)

Fuel filler pump is installed in the tool box. Use it when filling the fuel in a tank.

**NOTE!**

This pump is provided with an electronic overfilling protection.

- 1 Remove the strainer cover (E) which is installed to protect the strainer from dust at the end of hose (A).
- 2 Put the pump hose with strainer into the fuel barrel.
- 3 Press the green start button (B). The pump will run as long as the tank is not full.
  - At any time during the refuelling or when the drum has been emptied, the pump may be stopped by pressing the red button (C).
  - The pump will automatically stop when the fuel level sensor is actuated. The pump cannot be restarted until the fuel from the tank is used.
- 4 Fold the hose and reinstall the strainer cover.

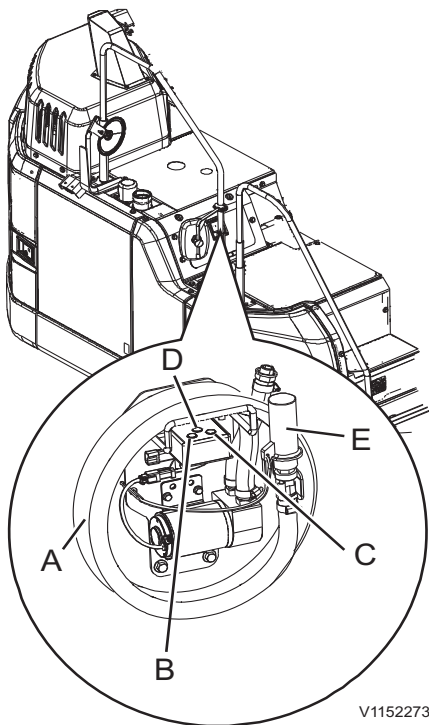

V1152273

- A Fuel filler pump hose
- B Start button (green)
- C Stop button (red)
- D Manual control button
- E Strainer cover

312 Maintenance  
Maintenance service, when required

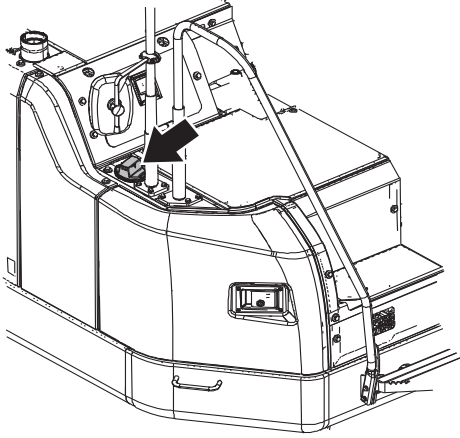

V1152274

AdBlue®/DEF tank cap

## AdBlue®/DEF, filling

### NOTICE

Risk of machine damage.  
Refilling fluids with anything other than what is specified in this manual could cause permanent damage to the catalyst system.  
Only refill fluids with those specified in this procedure.

### NOTICE

Risk of fuel tank contamination.  
Accidental filling of AdBlue®/DEF in to the fuel tank causes fuel tank contamination.  
Only use AdBlue®/DEF filling equipment that has a valve that opens only on machines equipped with a magnetic ring in the AdBlue®/DEF filler neck to avoid fuel tank contamination.

### NOTICE

Risk of machine damage.  
AdBlue®/DEF is highly corrosive. If the tank is overfilled, AdBlue®/DEF may leak out through the air vent pipe. If the tank is overfilled and the fluid in it freezes, the tank and hoses can be permanently damaged.  
Do not overfill the tank. Always stop filling when the fluid level reaches the filling port or when an automatic filling nozzle shuts off.

### NOTE!

Do not fill with any fluid other than that specified in ISO 22241-1. We recommend that you do not reuse drained AdBlue®/DEF due to the risk of contamination.

AdBlue®/DEF tank capacity, see page 353.

### NOTE!

Be careful not to overfill AdBlue®/DEF more than the tank capacity, otherwise it could overflow from the air breather line of the tank.

AdBlue®/DEF quality, see page 351.

If the AdBlue®/DEF level is low, an alarm indication is displayed. Fill the AdBlue®/DEF tank with AdBlue®/DEF.



Maintenance

---

Maintenance service, when required **313**

- AdBlue®/DEF is not classified as a hazardous substance but should still be handled with care. It is highly corrosive.
- If it comes into contact with the skin, rinse well with water.
- If it comes into contact with the eyes, rinse thoroughly for several minutes. Consult a doctor if necessary.
- If inhaled, breathe fresh air and contact a doctor if necessary.
- If swallowed, drink water and contact a doctor.
- Do not allow AdBlue®/DEF to come into contact with other chemicals.
- AdBlue®/DEF is not combustible. If AdBlue®/DEF is exposed to high temperatures it will decompose into ammonia and carbon dioxide.
- AdBlue®/DEF must not be mixed into the diesel tank and diesel must not be mixed into the AdBlue®/DEF tank.

**NOTE!**

AdBlue®/DEF filling equipment must be designed for a maximum filling rate of 40 litres/minute, and adjustable to a rate below 40 litres/minute. If filling problems occur and remain after the filling filter has been cleaned, please refer to the manual for the filling equipment and take the necessary action.

For distribution of AdBlue®/DEF (only valid for US market):

- Volvo CE Customer Support: 1-877-823-1111 (business hours)
- [www.volvoce.com](http://www.volvoce.com) (outside business hours)

For distribution of AdBlue®/DEF (all other markets), please contact your local Volvo dealer for more information.

## 314 Maintenance Maintenance service, when required

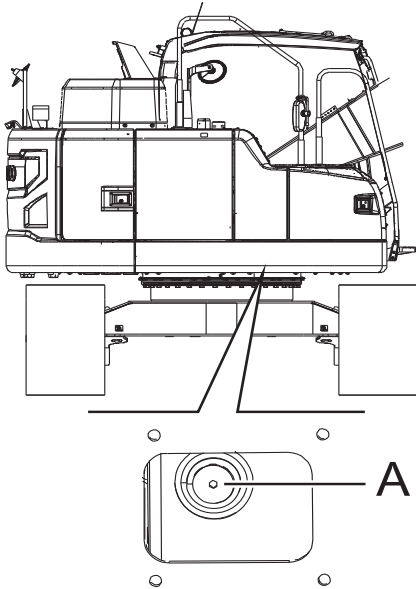

V1152275

A Drain plug

### AdBlue®/DEF tank, draining

- 1 Park the machine on a level ground and move the superstructure as shown in the figure.
- 2 Lower the bucket to the ground.
- 3 Turn the ignition switch to stop position.
- 4 Move the control lockout lever down to lock the system securely. See page 111.
- 5 Remove drain plug (A) using a L wrench from the tank.
- 6 Drain AdBlue®/DEF into a container.

#### **NOTICE**

Take care of filters, oils and liquids in an environmentally safe way.

- 7 Install the drain plug to the tank.

### Water separator, draining

The water separator filter element is designed to remove the water from the fuel supplied to the engine.

**Check and drain the water in the water separator filter element when the check screen for water in fuel pops up on the IC (Instrument Cluster).**

- 1 Place a suitable sized container under drain hose (E).
- 2 Open the drain valve (C) and drain the sediment into a container.

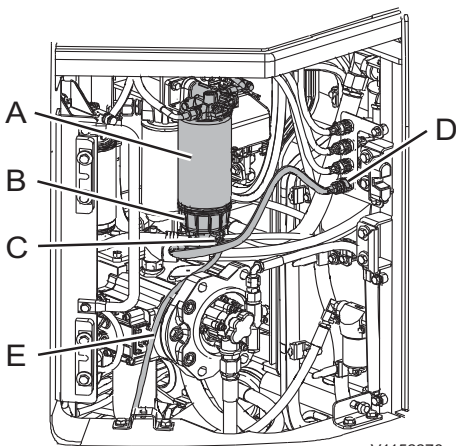

V1152276

- A Filter element
- B Bowl
- C Drain valve
- D Sensor connector
- E Drain hose

#### **NOTICE**

Take care of filters, oils and liquids in an environmentally safe way.

- 3 Close the drain valve (C).

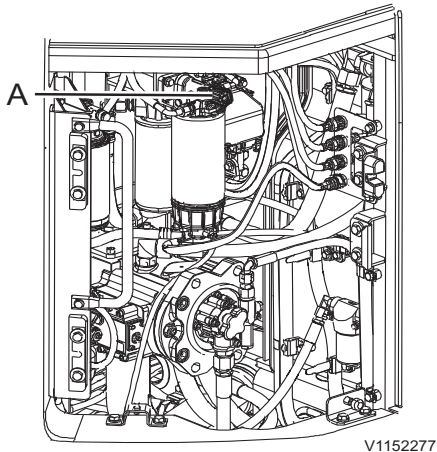

V1152277

A Hand pump

## Fuel system, bleeding

Air must be bled out of the fuel injection system whenever the machine runs out of fuel while the engine is running.

### **NOTICE**

Under no circumstances must starting attempts be made before the system has been bled. The fuel feed pump may be seriously damaged.

### **NOTE!**

Do not spill fuel on electrical components.

- 1 Turn hand pump (A) counterclockwise to unlock the plunger.
- 2 Pump hand pump (A) until a heavy resistance can be felt in the hand pump.
- 3 Push hand pump (A) fully and turn it clockwise to lock the plunger.
- 4 Start the engine and let it run in idle for 3 minutes.
- 5 If the engine is difficult to start, repeat (1) to (3).

### **NOTE!**

Do not use the hand pump when the engine is running.

- 6 Check for leakages.

316 Maintenance  
Maintenance service, when required

## Batteries, charging

### WARNING

Risk of serious injury.  
Short-circuit, open flames or sparks near a charging battery could lead to an explosion.

**Switch off charge current before disconnecting charging cable clamps. Never charge a battery near open flames or sparks. Always charge a battery in well-ventilated areas.**

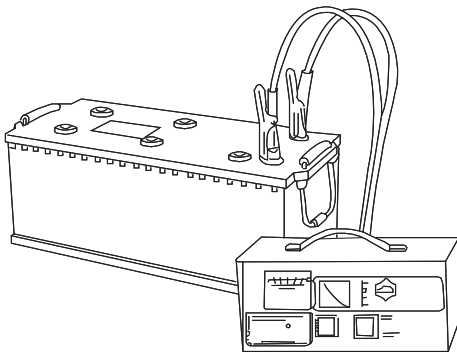

V1066032

### WARNING

Risk of chemical burns.

The battery electrolyte contains corrosive sulphuric acid which could cause severe chemical burns.

**If electrolyte spilled on your bare skin, remove it immediately and wash the affected area with soap and plenty of water. If it gets into your eyes or any other sensitive body part, rinse with plenty of water and seek immediate medical attention.**

- Always turn off the charging current before the charging lead clips are removed.
- Ventilate well, especially if the battery is charged in a confined space.

## Welding

The following measures should be taken before starting electric welding on the machine or attachments connected to the machine.

- 1 Turn off the electric power with the battery disconnect switch.
- 2 Disconnect the batteries, both the plus and minus terminal.
- 3 Disconnect the electronic units ; GPMECU1 (General Purpose Machine Electronic Control Unit1), EMS (Engine Management System), IC (Instrument Cluster), CCM (Climate Control Module) and so on. For further information, contact a workshop authorized by Volvo Construction Equipment.
- 4 Connect the welding equipment's ground connection as close to the welding point as possible and make sure that the current does not pass across a bearing.
- 5 Ventilate well, specially if the welding is performed in a confine space.
- 6 Remove all paint from an area of at least 10 cm (4 in) around the welding point.

### WARNING

Risk of toxin inhalation.

Burning of painted, plastic or rubber parts produces gases that could damage respiratory tracts.

**Never burn painted or rubber parts or any plastics.**

### NOTICE

**A fire extinguisher should be easily accessible during all welding work.**

### NOTE!

The weld will be related with inferior quality and strength, never weld directly on a painted surface.



## Cleaning machine

The machine should be cleaned regularly with conventional car care products in order to eliminate the risk of damage to the paint finish and other surfaces on the machine.

### **NOTICE**

Avoid using strong cleaning agents or chemicals in order to minimise the risk of damage to the paint finish.

### **NOTICE**

Soil and clay may damage or cause wear to moving parts of the undercarriage. Therefore, all parts must be cleaned regularly from of soil and clay.

### **NOTE!**

Daily clean the areas on the machine where dust, chips and similar may collect in order to minimise the risk of fire, see page 268.

- Place the machine in a place intended for cleaning.
- Follow the instructions supplied with the car care product.
- The water temperature must not exceed 80 °C (176 °F).
- If high-pressure wash is used, keep a distance of at least 40 cm (16 in) between the seals and the nozzle. Keep a distance of 30 cm (12 in) between nozzle and other machine surface. Too high pressure and too short distance may cause damage.





Maintenance

**Maintenance service, when required 319**

---

**NOTE!**

Protect electrical leads in an appropriate way and be careful not to damage the cab prefilter when cleaning the machine.

**NOTICE**

Do not spray with high pressure into the sealing of the slewing ring, the water may penetrate and affect the characteristics of the grease.

- Use a soft sponge.
- Finish by rinsing the whole machine with only water.
- Always lubricate the machine after washing.
- Touch-up the paint finish when required.

**Paint finish maintenance**

- Machines which are used in corrosive environment suffer more from rust than others. As a preventive measure it is recommended that the paint finish should be maintained every sixth months.
- At first clean the machine.
- Apply Dinol 77B (or corresponding transparent waxy anti-rust agent) at a thickness of 70-80 µ.
- A protective layer of underseal Dinitrol 447 (or corresponding) may be applied under the mudguards where mechanical wear is expected.

**Touch-up painting**

- Check if there are any damaged areas of the paint finish.
- At first clean the machine.
- Rectify any damage to paint finish in a professional way.

## Cleaning engine compartment

### WARNING

Risk of serious injury.  
Rotating parts could cause serious cutting or crushing injury.  
**Never open the engine hood when the engine is running.**

### WARNING

Risk of burns.  
Engine and exhaust system components get very hot and can cause severe burns.  
**Avoid contact with engine compartment covers, engine components and exhaust system until the engine is cooled down.**

Machines operating in dusty environment or environment exposed to fire hazards for example, wood-processing, woodchip handling or grain handling and animal feed industries require daily attention and cleaning of the engine compartment and surrounding areas.

When operating in other environments, inspection and cleaning is required at least once a week.

Loose material is removed with for example compressed air.

Cleaning should preferably be carried out at the end of the working shift before the machine is parked.

Use personal protective equipment such as protective goggles, gloves and respirator.

After cleaning, check and rectify any leaks. Close all covers and hoods.

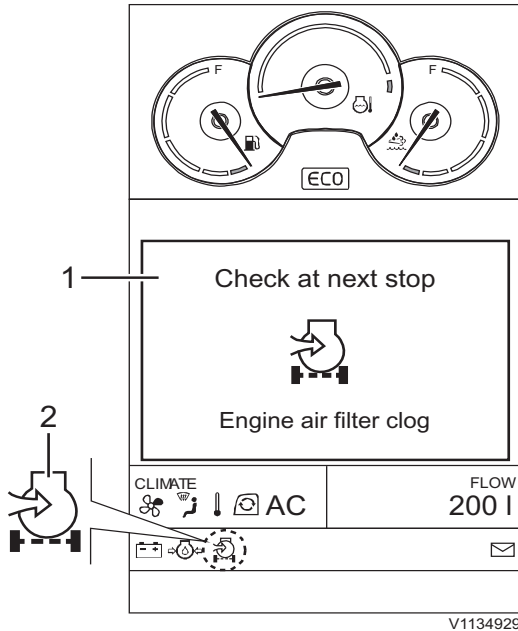

- 1 Check screen
- 2 Indicator

## Engine air cleaner

The air cleaner prevents dust and other impurities from entering the engine. The air first passes through the primary filter and then the secondary filter.

The degree of engine wear depends largely on the cleanliness of the induction air. Therefore, it is very important that the air cleaner should be checked regularly and maintained correctly. Observe great cleanliness when working with the air cleaner and filters.

### **NOTICE**

**Do not, under any circumstances, run the engine without a filter or with a damaged one. Always have a spare filter at hand and keep it well protected from dirt.**

Check regularly that hose and pipe connections from the air cleaner to the engine induction manifold do not leak.

## Engine air cleaner primary filter, cleaning and replacing

Clean the filter when the check screen for engine air filter clog pops up on the IC (Instrument Cluster). The filter may be cleaned, at the most, five times. Thereafter or after maximum 1 year, the filter should be replaced. Also replace the filter if it is damaged

**⚠ WARNING**

Risk of hazardous inhalation.

Dangerous dust can lead to serious health problems.

**Always wear personal protective equipment, including filter mask, eye protection and appropriate gloves when handling and cleaning the engine compartment, coolers and air filters.**

**NOTICE**

**Risk of machine damage!**

**Dust could enter the air intake system if the secondary filter comes off.**

**If the secondary filter comes off, clean the air cleaner housing thoroughly and make sure no dust enters the air intake system before reinstalling the secondary filter.**

- Do not use compressed air.
- Vacuum cleaning is recommended, because it minimizes the risk that dust enters the air intake system.
- A wet cloth may be used but be careful not to push any dust into the air intake system.

**NOTE!**

Do not clean the filter if the check screen does not pop up on the IC (Instrument Cluster).

**NOTE!**

Use Volvo genuine air filters. Otherwise Volvo may not support the engine failures.

If the indicator is still alight after replacing or cleaning the primary filter, the secondary filter must be replaced.

As the length of time between filter replacements depends entirely on the operating environment of the machine, it may sometimes be necessary to replace the filter more often.

When cleaning the primary filter, mark it on the secondary filter to recognize primary cleaning times.

Maintenance  
Maintenance service, when required **323**

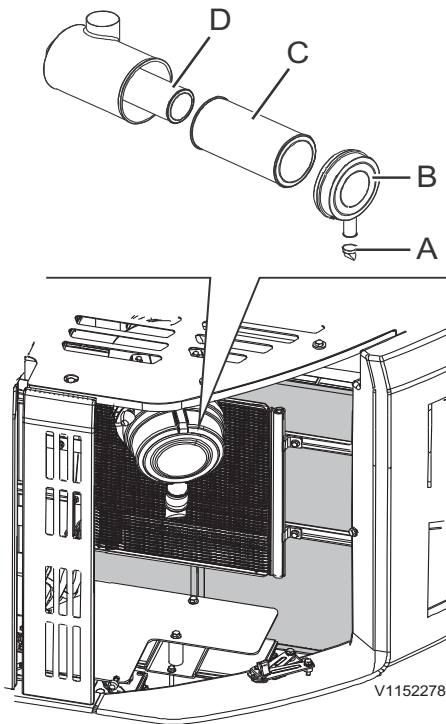

**Mechanical cleaning**

- 1 Open the cover.
- 2 Press with both thumbs on primary filter (C) at the same time as you pull it out. This is to prevent the secondary filter (D) from coming out together with the primary filter.
- 3 Carefully tap the end of the primary filter against a soft and clean surface.
- 4 Install the primary filter and the cover.

**NOTE!**

Do not tap against a hard object.

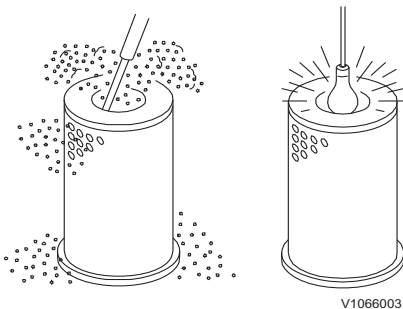

**Cleaning with compressed air**

- 1 Use clean and dry compressed air with a max. pressure of 500 kPa (5 bar) (73 psi). Do not hold the nozzle closer than 3 ~ 5 cm (1 ~ 2 in).
- 2 Blow the filter from the inside along the folds.
- 3 Check the filter with the aid of a lamp.
- 4 If there is the smallest hole, scratch, crack or other damage, the filter must be discarded.
- 5 Install the primary filter and the cover.

**NOTE!**

To discover the damage more easily, this check should be made in a darkened room.

## 324 Maintenance Maintenance service, when required

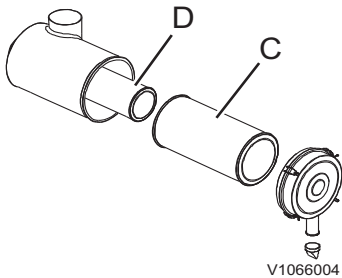

C Primary filter  
D Secondary filter

### Engine air cleaner secondary filter, replacing

Replace the secondary filter every 3rd time primary filter is replaced or at least every 2 years.

If the indicator is still alight even though the primary filter has been cleaned or replaced, the secondary filter should be replaced.

The secondary filter (D) works as a protective filter in case the primary filter (C) should be damaged.

#### NOTE!

The secondary filter should not be removed or cleaned! It acts as a protective filter in case the primary filter is damaged and should be replaced by a qualified service technician at the specified service interval or when required.

#### WARNING

Risk of hazardous inhalation.

Dangerous dust can lead to serious health problems.

**Always wear personal protective equipment, including filter mask, eye protection and appropriate gloves when handling and cleaning the engine compartment, coolers and air filters.**

#### NOTICE

**Risk of machine damage!**

**Dust could enter the air intake system if the secondary filter comes off.**

**If the secondary filter comes off, clean the air cleaner housing thoroughly and make sure no dust enters the air intake system before reinstalling the secondary filter.**

- Do not use compressed air.
- Vacuum cleaning is recommended, because it minimizes the risk that dust enters the air intake system.
- A wet cloth may be used but be careful not to push any dust into the air intake system.

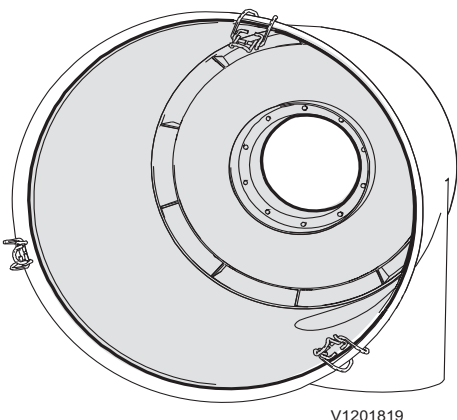

Use vacuum cleaner to clean the air cleaner outlet.

#### NOTICE

Take care of filters, oils and liquids in an environmentally safe way.

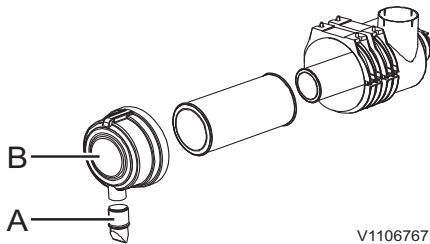

V1106767

- A Vacuator valve
- B Cover

## Engine air cleaner cover, cleaning

The cover for air cleaner should be cleaned when the primary filter is cleaned.

### WARNING

Risk of hazardous inhalation.

Dangerous dust can lead to serious health problems.

**Always wear personal protective equipment, including filter mask, eye protection and appropriate gloves when handling and cleaning the engine compartment, coolers and air filters.**

- 1 Remove the cover (B) and valve (A) from the air cleaner.
- 2 Empty and clean the cover and valve.
- 3 Reinstall them on the air cleaner.

## Radiator and coolers, cleaning

See page 300.

## Coolant level, checking

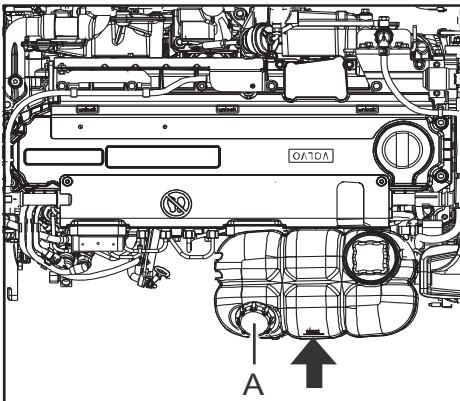

V1152376

- Main reservoir (for engine system)
- A Filler cap

326 Maintenance  
Maintenance service, when required

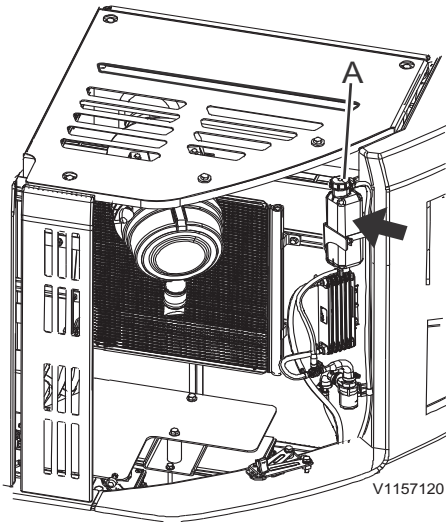

Sub reservoir (for SCR system)

A Filler cap

Check the coolant level when the warning screen for low coolant level pops up on the IC (Instrument Cluster), see page 44.

**! WARNING**

Risk of scalding and severe burns to unprotected skin.

High-pressurised hot coolant may rush out of expansion tank and cause severe burns. Before removing the expansion tank pressure cap:

- Shut down the engine.
- Allow the engine to cool
- Turn the pressure cap slowly to release any pressure.

- 1 Position the machine on even, firm and level ground.
- 2 Check the coolant level.  
If the coolant level is lower than "MIN" marking on the tank, top up the coolant through filler cap between "MIN" and "MAX" level.



## Track unit, adjusting tension

### **! WARNING**

Risk of serious injury

Recoil spring cylinder is filled with pressurised grease. High pressure grease in the cylinder could cause serious injury or death.

**Always keep face, hands and body away from the grease nipple and valve when adjusting the track tension or loosening the track. Never remove the grease fitting or nut and valve assembly to release grease.**

#### Tightening track tension - reducing slack

- 1 Fill the grease through grease nipple (B) using a grease gun with high pressure.
- 2 Check the tension by moving the machine forward and rearward.
- 3 Check the tension again. If not correct, adjust it again.

#### Loosening track tension - increasing slack

- 1 Loosen the valve (A) gradually to drain the grease, but not more than one turn.  
If the grease does not drained smoothly, move the machine forward and rearward.

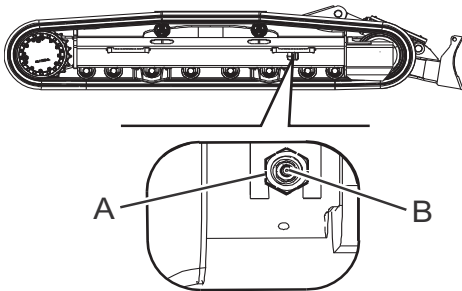

V1152377

- A Valve
- B Grease nipple

### **NOTICE**

Risk of environmental pollution!

The grease in the track adjustment cylinder is under high pressure and large quantities of grease will be quickly released if the valve is loosened too much. **Never loosen the valve by more than two turns when draining the grease.**

- 2 Close the valve (A) but do not tighten excessively as the fitting may be damaged.
  - The valve (A) assembly, tightening torque: 7.0 kgf m (51 lbf ft) (69 N m)
- 3 Check the tension by moving the machine forward and rearward.
- 4 Check the tension again. If not correct, adjust it again.

328 Maintenance  
Maintenance service, when required

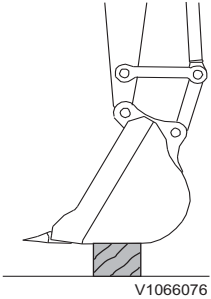

### Bucket teeth, replacing

Replace the bucket teeth before the adaptors wear away.

#### WARNING

Risk of splinter injury.

When striking metal objects with a hammer, flying metal chips could cause serious splinter injury to eyes and other body parts.

**Always wear personal protective equipment and eye protection when replacing bucket teeth.**

- Lower the bucket to the ground and position it to the easiest posture for working.
- Stop the engine before replacing the bucket tooth.

#### For side pin locking system

- 1 Lower the bucket horizontally and place it on a block.
- 2 Stop the engine and move the control lockout lever down to lock the system securely.
- 3 Drive out the pin (B) using a hammer and punch. Be careful not to damage the locking washer (C). Use a round bar with a smaller diameter than the pin as a punch.
- 4 Clean the surface of adapter (D) and insert a new locking washer (C) in the correct place, and then install a new tooth (A).
- 5 Drive the pin (B) into the pin groove until the pin is flush with the tooth.

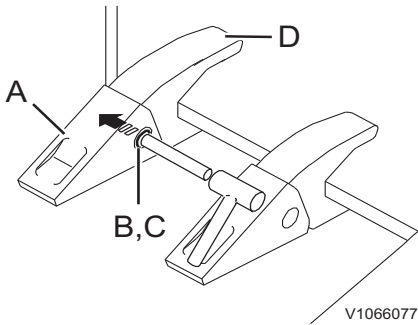

Maintenance  
Maintenance service, when required 329

For Volvo tooth system I (VTS)

Replace the bucket teeth before the adaptors wear away.

**! WARNING**

Risk of splinter injury.

Striking the bucket pin with a hammer could cause metal chips to fly around and cause serious splinter injury.

**Always wear face and eye protection, hard hat and gloves while removing and installing the bucket pins.**

A special tool may be ordered to facilitate replacement of teeth. The tool are available in different sizes depending on tooth size. Contact your dealer for further information.

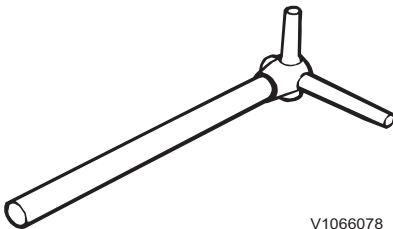

Special tool

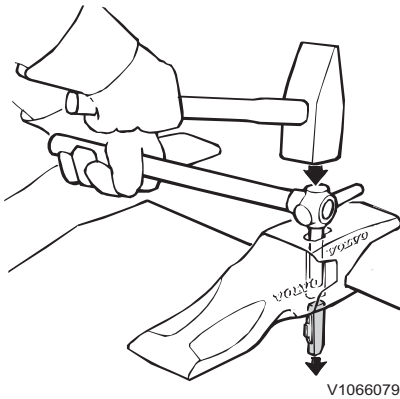

Knock out the locking device

**Removing tooth**

- 1 Lower the bucket horizontally on a block and angle it slightly upward.
- 2 Stop the engine and move the control lockout lever down to lock the system securely.
- 3 Clean the opening for tooth adapter locking device.
- 4 Knock out the locking device with a hammer and the tool or other suitable drift.
- 5 Remove tooth.

## Maintenance 330 Maintenance service, when required

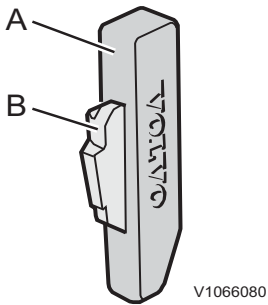

Locking device

A Steel pin

B Lock retainer

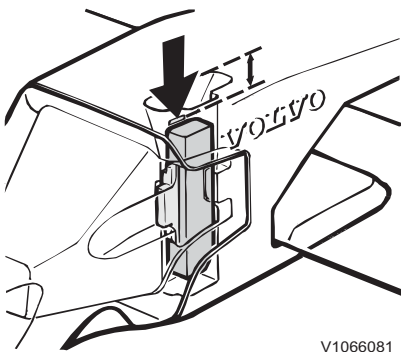

The locking device should be just below the scored line

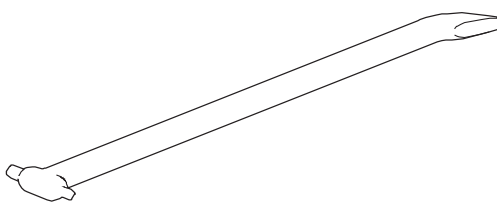

Special tool

V1205123

### Installing tooth

- 1 Clean the front part of the tooth adapter and the hole for the locking device.
- 2 Install the tooth so that the guide lugs fit in the tooth adapter recesses.
- 3 Replace lock retainer (B) with a new part.
- 4 Install the locking device so that the chamfered part points downward and the lock retainer points forward.
- 5 Knock down the locking device with a hammer until it is level with the upper part of the tooth adapter.
- 6 Knock down the locking device further with a hammer and the tool or other suitable drift until the upper part is just below the scored line in the hole.

### NOTE!

Replace the steel pin in connection with replacement of tooth adapter.

## Bucket teeth, replacing

### For Volvo tooth system II (VTS)

A special tool may be ordered to facilitate replacement of teeth. The tool is available in different sizes depending on tooth size. Contact your dealer for more information.

### WARNING

**Risk of crushing by falling attachments.**

Hydraulic or mechanical failure may cause the attachments to fall, resulting in severe personal injury or death.

Always support any attachment before adjusting or servicing it.

### Removing tooth

- 1 Lower the bucket to the ground and angle it slightly upward.

## Maintenance Maintenance service, when required 331

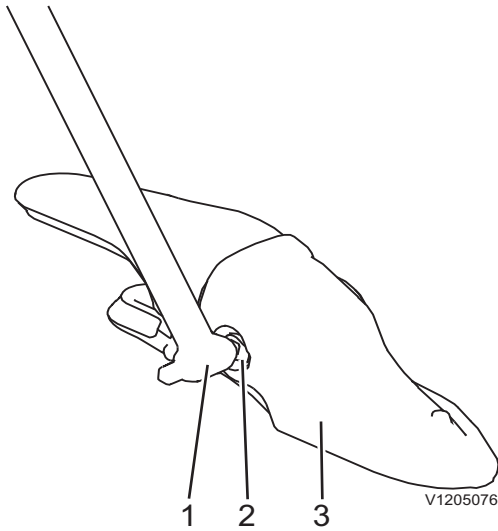

- 1 Special tool
- 2 Pin
- 3 Tooth

- 2 Clean the square hole in the pin.
- 3 Install the tool in the pin and turn it 90 degrees either way to unlock it.
- 4 Turn the tool back and forth, with an outwards motion, until the pin is removed. Use the pry bar end of the tool if the pin gets stuck.
- 5 Remove the tooth.

### Installing tooth

- 1 If changing the position of a tooth, check that the retainer is not bent or damaged.
- 2 Check that the pin is not bent or damaged.
- 3 Clean the front part of the adapter and the holes for the pin.
- 4 Place the tooth on the adapter.
- 5 Place the pin in the tooth. Check that the pin flange is aligned with the tooth.
- 6 Install the tool in the pin and turn it back and forth, with an inwards motion, until the pin is installed. A click sound will occur.
- 7 Check that the tooth is secured to the adapter.

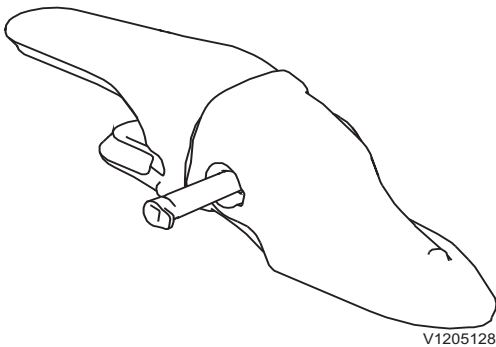

Tooth with pin

332 Maintenance  
Maintenance service, when required

## Hydraulic system, releasing pressure

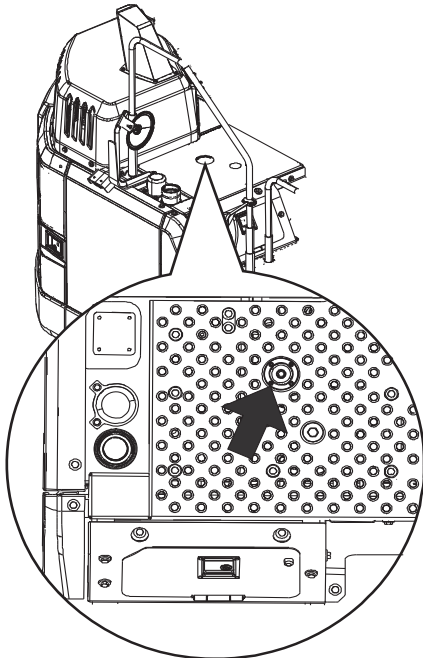

V1152378

Breather on the hydraulic tank

### **WARNING**

Risk of high pressure injection.

Residual pressure in the hydraulic system could lead to oil under high pressure jetting out and cause serious injury, even if the engine has not been running for some time.

**Always release the pressure before any kind of service of the hydraulic system is carried out.**

Use the greatest caution when working on the hydraulic system. Remove system pressure and tank pressure:

- 1 Place attachment on the ground and shut down engine.
- 2 After engine is shut down, turn ignition switch to running position (Do not start engine).
- 3 Keep the control lockout lever up (unlocked position) and move all control levers and pedals to release main system pressure from all lines.
- 4 Turn ignition switch to OFF position, remove the key and tag the machine to indicate that the unit is under service.
- 5 Lower the control lockout lever (locked position).
- 6 Press the pressure relief valve located on the hydraulic tank breather valve to release tank pressure.

## Accumulator, handling

### WARNING

Risk of serious injury.

Accumulators are charged with highly pressured nitrogen. Improper handling could lead to an explosion causing serious injury.

**Work on an accumulator must only be done by a qualified service technician.**

- Do not hit, drill or weld the accumulator.
- Keep it away from open flame or other highly heated sources.
- If you operate the operating lever downward just after the engine stops, the accumulator allows the attachment to move by its own weight.
- After releasing the pressure in accumulator, move the control lockout lever down to lock the system securely, see page 111.

### Accumulator, emergency operation

- 1 Stop the engine by turning the ignition switch to stop position.
- 2 Turn the ignition switch to running position
- 3 Move the control lockout lever up to unlock the system, see page 111.
- 4 Put the operating lever to boom down position to lower the attachment by its own weight.
- 5 Move the control lockout lever down to lock the system securely.

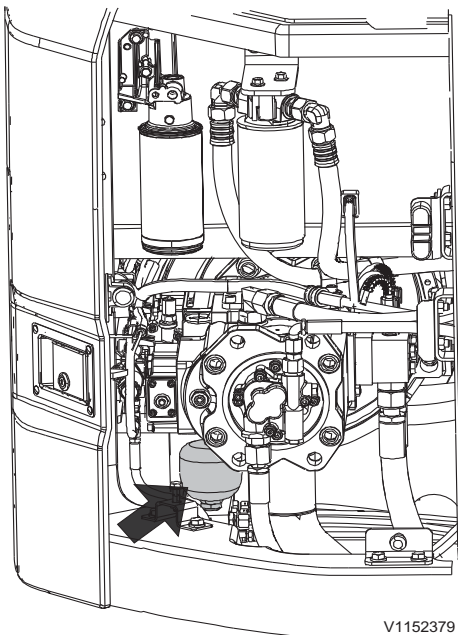

V1152379

Accumulator



## 334 Maintenance Maintenance service, when required

---

### Accumulator, pressure releasing

- 1 Lower the attachment or load completely to the ground.
- 2 If using X1 or X3 axillary hydraulic circuit, do not activate.
- 3 After turning off the engine, turn the ignition switch to operating position.
- 4 Move the control lockout lever up to unlock the system.
- 5 To release the pressure in the control circuits and accumulator, move the operating levers and pedals forward / rearward and left / right to their respective end positions.
- 6 Turn the ignition switch to stop position.
- 7 Move the control lockout lever down to lock the system securely.





## Recommended intervals for critical parts

To ensure safety at all times when operating or driving the machine, periodic maintenance must always be carried out. To maintain safety over time, it is also recommended that periodic check or replacement of the parts given in the table below, is carried out. These parts are closely connected to safety and fire prevention. The material ages or materials are wearing with foreseeable deterioration. If these parts show any abnormality before the recommended interval has passed, they should be repaired or replaced immediately. If the hose clamps show any deterioration, such as deformation or cracking, replace the clamps at the same as the hoses. When replacing the hoses, always replace the O-rings, gaskets, and other related parts at the same time. The replacements should be carried out by a qualified service technician.

Inspection interval	Item
Daily	Fuel / hydraulic hoses - leakage of connections and end fittings
Monthly	Fuel / hydraulic hoses - leakage, damage of connections and end fittings
Yearly	Fuel / hydraulic hoses - leakage, damage, deformity and aging of connections and end fittings

Critical parts list for periodic replacement	Recommended interval
Fuel hoses	Every 2 years or 4000 hours, which occurs first
Hydraulic hoses	Every 6 years or 6000 hours, which occurs first
Seat belt	Every 3 years



336 Maintenance  
Maintenance service, when required

Maintenance under special  
environmental conditions

Conditions	Maintenance	Related page
Water or near the ocean	Before operating, check the tightness of plugs and all drain hoses and cocks.	-
	After working, replenish the grease to the attachment pins or the areas affected by the water.	215
	When operating the machine, make sure to check and lubricate attachment points affected by water regularly.	288
	After working near the ocean, clean the machine thoroughly with fresh water and service the electrical parts to prevent from corrosion. It is highly recommended to use dielectric grease in all harness connecting points for better sealing and to prevent corrosion.	-
Freezing weather	After working, fill up the fuel tank to prevent water from condensing in the tank.	310
	Use the recommended lubricants.	338
	Fully charge the batteries regularly, electrolyte may freeze. Ventilate well especially when the batteries are charged in a confined space.	316
	When storing machines in extremely cold temperature, remove batteries and store them at room temperature.	193
	Before parking, remove the mud and the dirt from the tracks.	-
Demolition work	Use fall protection over the cab against falling objects.	217
Low fuel quality	Drain the sediments in fuel tank at shorter service intervals. (1)	-
	Change the engine oil and engine oil filter at shorter service intervals. (1)	-

1. Contact a workshop authorized by Volvo



Maintenance  
Maintenance service, when required **337**

Dusty atmosphere	Check regularly that hose and pipe connections from the air cleaner to the engine induction manifold do not leak.	321
	Clean the air filter at shorter service intervals.	321
	Clean the clogging net for radiator and oil cooler at shorter service intervals.	325
	Clean the areas on the machine where dust, chips and similar may collect at shorter service intervals in order to minimize the risk of fire.	318
	Pay attention to and clean the engine compartment and surrounding areas regularly.	320
Rocky ground	Use a suitable track for the ground conditions. If in doubt, contact your closest Volvo dealer for proper advice.	248
	Use a suitable attachment for the ground conditions such as a heavy duty bucket. <sup>(1)</sup>	-
Hammer operation	Change the hydraulic oil and return filter of hammer circuit at shorter service intervals. <sup>(1)</sup>	-

1. Contact a workshop authorized by Volvo



# Specifications Recommended lubricants

## Recommended lubricants

The Volvo lubricants have been specially developed to fulfil the demanding operating conditions, in which Volvo excavators are used in. The oils have been tested according to Volvo excavator specifications and therefore meet the high requirements for safety and quality. Other mineral oils can be used if they conform to our viscosity recommendations and meet our quality requirements. The approval of Volvo is required, if any other oil base quality (for example biologically degradable oil) is to be used.

System	Oil grade	Recommended viscosity at varying ambient temperature																				
Engine	Engine oil For detail, see page 341.	<table border="1"> <tr> <td>°C</td> <td>-30</td> <td>-20</td> <td>-10</td> <td>0</td> <td>+10</td> <td>+20</td> <td>+30</td> <td>+40</td> <td>+50</td> </tr> <tr> <td>°F</td> <td>-22</td> <td>-4</td> <td>-14</td> <td>+32</td> <td>+50</td> <td>+68</td> <td>+86</td> <td>+104</td> <td>+122</td> </tr> </table>	°C	-30	-20	-10	0	+10	+20	+30	+40	+50	°F	-22	-4	-14	+32	+50	+68	+86	+104	+122
°C	-30	-20	-10	0	+10	+20	+30	+40	+50													
°F	-22	-4	-14	+32	+50	+68	+86	+104	+122													
Fuel	Diesel fuel For detail, see page 345.	<table border="1"> <tr> <td>°C</td> <td>-30</td> <td>-20</td> <td>-10</td> <td>0</td> <td>+10</td> <td>+20</td> <td>+30</td> <td>+40</td> <td>+50</td> </tr> <tr> <td>°F</td> <td>-22</td> <td>-4</td> <td>-14</td> <td>+32</td> <td>+50</td> <td>+68</td> <td>+86</td> <td>+104</td> <td>+122</td> </tr> </table> <p><b>NOTE!</b> The fuel should at least meet the legal requirement, and national and international standards for marketed fuels, for example : EN590 (with nationally adapted temperature requirements), ASTM D975 No 1-D and No 2-D, JIS KK 2204.</p>	°C	-30	-20	-10	0	+10	+20	+30	+40	+50	°F	-22	-4	-14	+32	+50	+68	+86	+104	+122
°C	-30	-20	-10	0	+10	+20	+30	+40	+50													
°F	-22	-4	-14	+32	+50	+68	+86	+104	+122													
Cooling system	Volvo Coolant VCS Ready Mixed For detail, see page 342.	<p><b>Volvo Coolant VCS Ready Mixed</b> should be used only.</p> <p><b>NOTE!</b> The content of Volvo coolant must not be less than 40% of the total mixture.</p>																				

\*: Installed at factory

\*\*\*: VDS-4 or VDS-4.5 approved oils only. Other oils can be used up to +30°C (86°F).



Specifications  
**Recommended lubricants 339**

System	Oil grade	Recommended viscosity at varying ambient temperature																																																	
Hydraulic system	Hydraulic oil for severe cold area or if siberian option kit is installed	<table border="1"> <tr> <td>°C</td> <td>-30</td> <td>-20</td> <td>-10</td> <td>0</td> <td>+10</td> <td>+20</td> <td>+30</td> <td>+40</td> <td>+50</td> </tr> <tr> <td>°F</td> <td>-22</td> <td>-4</td> <td>-14</td> <td>+32</td> <td>+50</td> <td>+68</td> <td>+86</td> <td>+104</td> <td>+122</td> </tr> <tr> <td></td> <td colspan="9" style="text-align: center;">ISO VG15</td> </tr> </table>	°C	-30	-20	-10	0	+10	+20	+30	+40	+50	°F	-22	-4	-14	+32	+50	+68	+86	+104	+122		ISO VG15																											
	°C	-30	-20	-10	0	+10	+20	+30	+40	+50																																									
	°F	-22	-4	-14	+32	+50	+68	+86	+104	+122																																									
		ISO VG15																																																	
Volvo Hydraulic Oil Volvo 98609 Extra 46 or Volvo Hydraulic Oil Volvo 98609 Extra 68	<table border="1"> <tr> <td>°C</td> <td>-30</td> <td>-20</td> <td>-10</td> <td>0</td> <td>+10</td> <td>+20</td> <td>+30</td> <td>+40</td> <td>+50</td> </tr> <tr> <td>°F</td> <td>-22</td> <td>-4</td> <td>-14</td> <td>+32</td> <td>+50</td> <td>+68</td> <td>+86</td> <td>+104</td> <td>+122</td> </tr> <tr> <td></td> <td colspan="9" style="text-align: center;">ISO VG32 HV</td> </tr> <tr> <td></td> <td colspan="9" style="text-align: center;">ISO VG46 HV</td> </tr> <tr> <td></td> <td colspan="9" style="text-align: center;">ISO VG68 HV</td> </tr> </table>	°C	-30	-20	-10	0	+10	+20	+30	+40	+50	°F	-22	-4	-14	+32	+50	+68	+86	+104	+122		ISO VG32 HV										ISO VG46 HV										ISO VG68 HV								
°C	-30	-20	-10	0	+10	+20	+30	+40	+50																																										
°F	-22	-4	-14	+32	+50	+68	+86	+104	+122																																										
	ISO VG32 HV																																																		
	ISO VG46 HV																																																		
	ISO VG68 HV																																																		
Volvo Hydraulic Oil Volvo 98610 Biodegradable 46	<table border="1"> <tr> <td>°C</td> <td>-30</td> <td>-20</td> <td>-10</td> <td>0</td> <td>+10</td> <td>+20</td> <td>+30</td> <td>+40</td> <td>+50</td> </tr> <tr> <td>°F</td> <td>-22</td> <td>-4</td> <td>-14</td> <td>+32</td> <td>+50</td> <td>+68</td> <td>+86</td> <td>+104</td> <td>+122</td> </tr> <tr> <td></td> <td colspan="9" style="text-align: center;">Bio oil VG46</td> </tr> </table> <p><b>NOTE!</b> If the machine is filled with Volvo Biodegradable hydraulic oil this oil must also be used when filling and changing. The mineral oil content in bio oil should not exceed 2% when changing from mineral oil to bio oil. Contact a workshop authorised by Volvo.</p>	°C	-30	-20	-10	0	+10	+20	+30	+40	+50	°F	-22	-4	-14	+32	+50	+68	+86	+104	+122		Bio oil VG46																												
°C	-30	-20	-10	0	+10	+20	+30	+40	+50																																										
°F	-22	-4	-14	+32	+50	+68	+86	+104	+122																																										
	Bio oil VG46																																																		
Volvo Hydraulic Oil Volvo 98620 Ultra 46 or Volvo Hydraulic Oil Volvo 98620 Ultra 68	<table border="1"> <tr> <td>°C</td> <td>-30</td> <td>-20</td> <td>-10</td> <td>0</td> <td>+10</td> <td>+20</td> <td>+30</td> <td>+40</td> <td>+50</td> </tr> <tr> <td>°F</td> <td>-22</td> <td>-4</td> <td>-14</td> <td>+32</td> <td>+50</td> <td>+68</td> <td>+86</td> <td>+104</td> <td>+122</td> </tr> <tr> <td></td> <td colspan="9" style="text-align: center;">ISO VG32</td> </tr> <tr> <td></td> <td colspan="9" style="text-align: center;">ISO VG46</td> </tr> <tr> <td></td> <td colspan="9" style="text-align: center;">ISO VG68</td> </tr> </table>	°C	-30	-20	-10	0	+10	+20	+30	+40	+50	°F	-22	-4	-14	+32	+50	+68	+86	+104	+122		ISO VG32										ISO VG46										ISO VG68								
°C	-30	-20	-10	0	+10	+20	+30	+40	+50																																										
°F	-22	-4	-14	+32	+50	+68	+86	+104	+122																																										
	ISO VG32																																																		
	ISO VG46																																																		
	ISO VG68																																																		



Specifications  
**340 Recommended lubricants**

System	Oil grade	Recommended viscosity at varying ambient temperature																																								
Track gearbox	Volvo Axle Oil 80W-90 GL-5 or	<table border="1"> <tr> <td>°C</td> <td>-30</td> <td>-20</td> <td>-10</td> <td>0</td> <td>+10</td> <td>+20</td> <td>+30</td> <td>+40</td> <td>+50</td> </tr> <tr> <td>°F</td> <td>-22</td> <td>-4</td> <td>-14</td> <td>+32</td> <td>+50</td> <td>+68</td> <td>+86</td> <td>+104</td> <td>+122</td> </tr> <tr> <td></td> <td></td> <td></td> <td></td> <td></td> <td></td> <td></td> <td></td> <td></td> <td></td> </tr> <tr> <td></td> <td></td> <td></td> <td></td> <td></td> <td></td> <td></td> <td></td> <td></td> <td></td> </tr> </table> <p>*SAE 90</p> <p>SAE 140</p> <p>Or corresponding gearbox oil below.</p> <ul style="list-style-type: none"> <li>- Mobil SHC630</li> <li>- Chevron Cetus HiPerSYN Oil 220</li> </ul>	°C	-30	-20	-10	0	+10	+20	+30	+40	+50	°F	-22	-4	-14	+32	+50	+68	+86	+104	+122																				
°C	-30		-20	-10	0	+10	+20	+30	+40	+50																																
°F	-22		-4	-14	+32	+50	+68	+86	+104	+122																																
Swing gearbox	Volvo Axle Oil 85W-140 GL-5 or																																									
PTO gearbox (EC950E only)	Volvo Axle Oil Volvo 97317 75W-80 GO102 or Volvo Axle Oil Limited Slip 85W-90 GL-5																																									
Swing ring gear (Bath and Ball)	Volvo Lithium Grease EP2	<table border="1"> <tr> <td>°C</td> <td>-30</td> <td>-20</td> <td>-10</td> <td>0</td> <td>+10</td> <td>+20</td> <td>+30</td> <td>+40</td> <td>+50</td> </tr> <tr> <td>°F</td> <td>-22</td> <td>-4</td> <td>-14</td> <td>+32</td> <td>+50</td> <td>+68</td> <td>+86</td> <td>+104</td> <td>+122</td> </tr> <tr> <td></td> <td></td> <td></td> <td></td> <td></td> <td></td> <td></td> <td></td> <td></td> <td></td> </tr> <tr> <td></td> <td></td> <td></td> <td></td> <td></td> <td></td> <td></td> <td></td> <td></td> <td></td> </tr> </table> <p>Multi purpose EP** grease NLGI 2</p> <p>Or corresponding grease on lithium base with EP** additives and consistency NLGI class 2.</p>	°C	-30	-20	-10	0	+10	+20	+30	+40	+50	°F	-22	-4	-14	+32	+50	+68	+86	+104	+122																				
°C	-30	-20	-10	0	+10	+20	+30	+40	+50																																	
°F	-22	-4	-14	+32	+50	+68	+86	+104	+122																																	
Pin and bushing	Ultra Grease Moly EP2 or Volvo Lithium Grease EP2(a) For detail, see page 344.	<table border="1"> <tr> <td>°C</td> <td>-30</td> <td>-20</td> <td>-10</td> <td>0</td> <td>+10</td> <td>+20</td> <td>+30</td> <td>+40</td> <td>+50</td> </tr> <tr> <td>°F</td> <td>-22</td> <td>-4</td> <td>-14</td> <td>+32</td> <td>+50</td> <td>+68</td> <td>+86</td> <td>+104</td> <td>+122</td> </tr> <tr> <td></td> <td></td> <td></td> <td></td> <td></td> <td></td> <td></td> <td></td> <td></td> <td></td> </tr> <tr> <td></td> <td></td> <td></td> <td></td> <td></td> <td></td> <td></td> <td></td> <td></td> <td></td> </tr> </table> <p>*ISO-L-XBCFB2</p> <p>Or corresponding grease on lithium base with EP** additives and consistency NLGI class 2.</p>	°C	-30	-20	-10	0	+10	+20	+30	+40	+50	°F	-22	-4	-14	+32	+50	+68	+86	+104	+122																				
°C	-30	-20	-10	0	+10	+20	+30	+40	+50																																	
°F	-22	-4	-14	+32	+50	+68	+86	+104	+122																																	
Air conditioner system	Refrigerant	HFC R134a																																								

a) Volvo Lithium Grease EP2 is not recommended when the ambient temperature is above 40 °C.

\*: Installed at factory

\*\* : Extreme Pressure



### Engine oil

Follow recommended change intervals according to the oil's grade and sulphur content in the fuel.

Oil grade	Sulphur content in the fuel, ppm (10000 ppm = 1%)				
	< 15	15 - 500	500 - 3000	3000 - 5000	> 5000
	Oil change interval				
Volvo Engine Oil VDS-4.5 10W-30 or Volvo Engine Oil VDS-4.5 15W-40 or Other approved VDS-4.5 oil	500 hours	<b>Not applicable</b>			
Volvo Engine Oil VDS-4 10W-30 or Volvo Engine Oil VDS-4 15W-40 or Other approved VDS-4 oil					
ACEA: E9	250 hours	<b>Not applicable</b>			
API: CJ-4 or CK-4					

- ACEA: European Automobile Manufacturers Association
- API: American Petroleum Institute

342 Specifications  
Recommended lubricants

### Coolant

Only use Volvo Coolant VCS when topping up or changing coolant. To avoid damage to engine and cooling system, different coolants or corrosion protection must not be mixed. When using concentrated Volvo Coolant VCS and clean water, the mixture should contain 40–60% concentrated coolant and 60–40% clean water. The amount of concentrated coolant must never be less than 40% of the total mixture, see table below.

Freeze protection down to	Mixed-in amount of concentrated coolant
-25 °C (-13 °F)	40%
-35 °C (-31 °F)	50%
-46 °C (-51 °F)	60%

The concentrated coolant must not be mixed with water that contains a high degree of lime (hard water), salt or metals.

The clean water for the cooling system must also meet the following requirements:

Description	Value
Total number of solid particles	< 340 ppm
Total hardness	< 9.5° dH
Chloride	< 40 ppm
Sulphate	< 100 ppm
pH value	5.5-9
Silica	< 20 mg SiO <sub>2</sub> /litre
Iron	< 0.10 mg Fe/litre
Manganese	< 0.05 mg Mn/litre
Electrical conductivity	< 500 µS/cm
Organic material, COD-Mn	< 15 mg/litre

If there is any doubt about the water quality, use ready-mixed Volvo Coolant VCS, which contains 40% concentrated coolant. Do not mix with any other ready-mixed coolants since this may result in engine damage.





## Hydraulic oil

Only use Volvo genuine hydraulic oil approved by Volvo Construction Equipment must be used. Do not mix different brands of hydraulic oil as this can lead to damage in the hydraulic system.

For the hydraulic oil specification, see page 338.

	Ambient temperature											
	°C	-40	-30	-20	-10	0	+10	+20	+30	+40	+50	+60
	°F	-40	-22	-4	+14	+32	+50	+68	+86	+104	+122	+140
<b>Oil grade</b>		(B)		(A)				(C)				
			(B)		(A)				(C)			
				(B)		(A)						

(A) : Ambient temperature recommended for general use of hydraulic system and components.

(B) : Ambient temperature guide for machine operation from a hydraulic oil viewpoint only, it does not guarantee the completion machine for other conditions like engine starting performance. In this range a warming-up period is needed to obtain proper performance.

(C) : Ambient temperature range to operate machine under special conditions, not a recommendation for general use conditions.

### Additional recommendation for severe cold areas

A field solution for severe cold condition of ambient temperature between -40°C and +20°C.

- Type : Anti-wear type hydraulic oil
- Viscosity characteristic

Viscosity index : More than 130

Kinematic Viscosity : Less than 5,000cSt at -40°C, More than 5.6cSt at +90°C

### NOTE!

This value is approximately equivalent to ISO Viscosity grade #22.

### NOTE!

It is minimum theoretical recommendation without the guarantee of machine condition.



344 Specifications  
Recommended lubricants

**Grease**

Recommended grease for all digging equipment greasing points

Manufacturer	Product name	
	Recommendations	Alternatives*
VOLVO	Ultra Grease Moly EP2	Volvo Lithium Grease EP2
CALTEX	Molytex EP2	Multifak EP2
GULF	Gulflex Moly EP	Gulfcrown EP2
EXXONMOBIL	Beacon EP2 Moly	Beacon EP2
SHELL	Retinax HDX2 / Alvania HDX2	Retinax EP2 / Alvania EP2
TOTAL	Multis MS2	Multis EP2
CASTROL	Pyro LM	Pyroplex Red

\* Alternatives are not recommended when the ambient temperature is above 40 °C.

Mixability of types of grease with different additives

	Mixability of types of grease with additives					
	Lithium	Calcium	Lithium complex	Calcium complex	Aluminium complex	Clay
Lithium	√	√	√			
Calcium	√	√	√			√
Lithium complex	√	√	√	√		
Calcium complex			√	√		
Aluminium complex			√		√	
Clay		√			√	√

√ : Acceptable



## Fuel system

### Fuel

#### Fuel quality requirements

The fuel should at least meet the legal requirements, national and international standards for marketed fuels, for example: EN590 (with nationally adapted temperature requirements), ASTM D 975 No. 1D and 2D, JIS KK 2204. Fuel specification varies according to the working temperature. Please contact authorized Volvo dealer.

#### Sulphur content

According to current USA legal requirement, the sulphur content in the diesel fuel must not exceed 0.0015 percent (15 ppm) by weight.

According to current EU/other countries legal requirements, the sulphur content in the diesel fuel must not exceed 0.001 percent (10 ppm) by weight.

#### Bio-diesel fuel

Vegetable oils and / or esters, also called "bio-diesel", (e.g. rape-seed methyl ester RME fuel), which are offered on certain markets both as pure products and as mixed into the diesel fuel.

Volvo Construction Equipment accepts a maximum intermix of 7% bio-diesel fuel in the diesel fuel, ready mixed from the oil companies. A higher intermix than 7% of bio-diesel fuel may cause:

- Increased emission by nitrogen oxide, (thereby not meeting legal requirements)
- Shorter service life of engine and injection system
- Increased fuel consumption
- Altered engine output
- Shortening the engine oil change interval to a half
- Shortened service life of rubber materials in the fuel system
- Less good cold handling properties of the fuel
- Limit storage time for the fuel, which may cause clogging up of the fuel system if the machine is laid up for longer periods

#### Warranty condition

The warranty does not cover damage caused by an intermix of more than 7% of bio-diesel fuel.

### Alternative fuels

**This statement is only valid for Volvo branded engines.**

Hydro-treated vegetable oil (HVO) and fatty acid methyl ester (FAME) biodiesel are both made from renewable raw materials such as vegetable oils and animal fats, but they are chemically processed in different ways.

### Hydro-treated vegetable oil (HVO)

HVO is created using a chemical process called hydro-treating. Hydro-treating creates an oxygen-free hydrocarbon product that is very similar to distillate diesel fuel and is well suited for use in diesel engines. HVO fuels complying with the CEN diesel fuel standard EN 590:2013 or with the European Fuel Quality Directive 98/70/EC are approved for use in all Volvo Construction Equipment diesel engines with no changes to maintenance intervals. Paraffinic diesel fuels complying with the CEN standard EN 15940 may be used in all machines operating outside the European Union and for EU-certified engines up to the emission level Stage IV. These fuels may also be used for the EU-certified D11, D13 and D16 engines meeting the emission level Stage V.

### Biodiesel

Biodiesel is a product made from renewable resources such as vegetable oils or animal fat. Biodiesel that has been chemically processed into fatty acid methyl ester (FAME) can be blended with distillate diesel fuel and used in some diesel engines. Unblended biodiesel is referred to as B100 because it is 100% biodiesel.

Rapeseed methyl ester (RME) is the most common type of FAME used in Europe. Soy methyl ester (SME) and sunflower oil methyl ester (SOME) are the most common types of FAME used in the US. Although use of FAME biodiesel is now a legal requirement in some markets, it is not as suitable for use in diesel engines as conventional diesel fuel or HVO (hydro-treated vegetable oil).

### Biodiesel fuel requirements

The FAME biodiesel blends specified in the table below are approved for use if:

- The biodiesel is pre-blended by the fuel supplier
- The biodiesel used in the blend conforms to EN14214 or ASTM D6751
- The distillate fuel used in the blend meets fuel sulphur requirements
- The distillate fuel used in the blend conforms to EN590 or ASTM D975
- B1-B5 biodiesel blends conform to EN590 or ASTM D975
- B6-B7 biodiesel blends conform to EN590 or ASTM D7467



**Specifications**  
**Fuel system**      **347**

- B8-B20 biodiesel blends conform to EN16709(B20) or ASTM D7467

Engine emission designation	Engine size	Acceptable blend
EU Stage II / US Tier 2 * EU Stage IIIA / US Tier 3 * EU Stage IIIB / US Tier 4 interim EU Stage IV / US Tier 4 final EU Stage V	Below D4 / 4 litres	Up to B7
EU Stage II / US Tier 2 * EU Stage IIIA / US Tier 3 * EU Stage IIIB / US Tier 4 interim EU Stage IV / US Tier 4 final	D4–D8	Up to B7
EU Stage II / US Tier 2 * EU Stage IIIA / US Tier 3 * US Tier 4 final, special North America arrangement **	D9–D16	Up to B20
EU Stage IIIB / US Tier 4 interim EU Stage IV / US Tier 4 final	D11–D16	Up to B10
EU Stage IIIB / US Tier 4 interim, equipped with High Sulphur Fuel Conversion Kit (only available in unregulated markets) EU Stage IV / US Tier 4 final, equipped with High Sulphur Fuel Conversion Kit (only available in unregulated markets)	D4–D16	Up to B20



Engine emission designation	Engine size	Acceptable blend
EU Stage V	D4–D16	Up to B7
<p>* As Tier 2 and Tier 3 emissions regulations ended in 2005 and 2010 respectively, engines produced since then typically <b>meet Stage II / Stage IIIA regulations</b>, allowing their sale in less regulated markets.</p> <p>** With additional restrictions and special operating conditions, equipment used in North America may operate on B20 diesel.</p>		

**NOTE!**

Failures directly caused by the use of poor quality biofuel, or any other fuel not conforming to standards, are not factory defects and the manufacturer’s warranty does not apply.

**Maintenance interval requirements**

Additional service actions and shorter maintenance intervals are mandatory when using biodiesel blends above B10.

<b>Every 10 hours</b>
<ul style="list-style-type: none"> <li>- Check the engine oil and change if it rises above the maximum fill level</li> <li>- Inspect the fuel system components and replace as necessary</li> </ul>
<b>Half of original interval</b>
<ul style="list-style-type: none"> <li>- Change the engine oil and filter</li> <li>- Replace the fuel filter(s)</li> </ul>
<b>Every year, regardless of operating hours</b>
<ul style="list-style-type: none"> <li>- Change the engine oil and filter</li> <li>- Clean the fuel tank</li> </ul>

**Effects of biodiesel on engine oil**

Using biodiesel can lead to increased oil dilution. Use engine oil analysis tools frequently to check for fuel dilution and monitor engine oil condition. Check the engine oil level daily. Always change the engine oil if the oil level rises above the maximum fill level.

**Effects of biodiesel on fuel systems**

Biodiesel dissolves and loosens some fuel system deposits. During the initial conversion to biodiesel, loosened deposits will travel to the fuel filters and require more frequent fuel filter replacements. Start with new fuel filters when using biodiesel for the first time.

Biodiesel is aggressive to some materials used in fuel system components. Inspect seals, hoses, rubber and plastic components every 10 hours. Repair or replace any components that are damaged, softened or leaking. Clean biodiesel from painted surfaces immediately to prevent paint damage.

Biodiesel is more sensitive to bacteria and water contamination than distillate diesel fuel.

- Use as much fuel as possible before refilling the fuel tank in order to prevent bacteria growth if a machine is in regular use, e.g. regularly uses up a tank of fuel within a week. In climates where condensation is a risk, or when the machine is working for short durations, keep the fuel tank full.
- Do not use biodiesel in machines with low utilization or operating time.
- Do not store machines for more than 4 weeks without flushing biodiesel out of the fuel system by operating the machine through at least one full tank of distillate diesel fuel.
- Always follow the manufacturer's storage recommendations and "best-before" dates for each delivery of biodiesel.

#### **Effects of biodiesel on exhaust aftertreatment systems**

Biodiesel leaves higher levels of ash in diesel particulate filters and may require more frequent diesel particulate filter (DPF) regeneration and cleaning. Biodiesel can cause deviations in temperatures and functionality of the DPF burner and may cause fault codes or errors.

Biodiesel exhaust gas is aggressive to some materials used in selective catalytic reduction systems (SCR) and may require more frequent cleaning, repairing or replacing of SCR parts.

#### **Effects of biodiesel on cold weather operation**

Biodiesel has a high viscosity at temperatures below 0 °C (32 °F) and may cause problems starting the engine. Use a fuel heater or park machines in a heated building if possible.

#### **Effects of biodiesel on engine performance**

Biodiesel B100 has about 8% lower energy density compared to regular diesel fuel. Blends equal or lower than B20 have a small impact on engine performance.

**Effects of biodiesel on emissions compliance**

Engines are certified to comply with U.S. EPA, California and EU emissions standards based upon the use of test fuels with specifications established by these regulatory agencies. Alternative fuels, including biodiesel, that are not substantially similar to the required test fuels may adversely affect engine emissions compliance. As a result, Volvo does not warrant that the engine will conform to applicable Federal or California and EU emissions limits when operated on, or having previously being operated on, biodiesel or other alternative fuels that are not substantially similar to specified test fuels used for certification, nor if biodiesel / regular diesel is used in blends that exceed the recommendations.

However, the use of biodiesel up to a maximum of 20% (B20) in and of itself, will not affect the manufacturer's mechanical warranty as to engine or emissions system, provided the bio fuel used in the blend conforms to the applicable standards and the additional steps outlined herein are followed.





## AdBlue®/DEF

### NOTICE

#### Risk of machine damage.

In the short term, use of the wrong fluid can lead to reduced engine power. In the long term, it can lead to damage to the SCR-system and the catalyst. Reusing AdBlue®/DEF can lead to contamination. Damages caused by the use of incorrect fluids will not be covered by the warranty.

**Always use fluid specified in ISO 22241-1. Do not reuse drained AdBlue®/DEF.**

For reducing nitrogen oxides (NO<sub>x</sub>) the engine is equipped with a selective catalytic reduction (SCR) system. A diesel exhaust fluid is needed for the process to work. The fluid is called AdBlue® in Europe and Asia, but in North America it is called Diesel Exhaust Fluid (DEF). When needed, the SCR system warms up the AdBlue®/DEF-tank and lines.

The fluid is filled in a separate tank, which is completely separated from the fuel tank. AdBlue®/DEF may not be mixed in the fuel tank and fuel may not be mixed in the AdBlue®/DEF-tank.

AdBlue®/DEF consists of urea crystals (32.5%) and distilled water (67.5%). It is transparent, clear, and has a slight odour of ammonia. The fluid is not considered to be hazardous, but should still be handled with care. It is very corrosive, especially with copper and aluminium. For this reason, avoid spilling the fluid on electric cables and components. Always wipe up any spilled AdBlue®/DEF.

AdBlue®/DEF is not a combustible product. When exposed to high temperatures it will convert to ammonia and carbon dioxide. The fluid should not come into contact with other chemicals or be mixed with other chemicals.

AdBlue®/DEF is sensitive to both high and low temperatures. It should not be exposed to direct sunlight for any extended period of time. If the machine is not in use, AdBlue®/DEF starts to freeze at -11 °C (12 °F). The fluid volume in the tank increases when frozen, this is why it is important to follow the recommended fill volume. AdBlue®/DEF does not break down or degrade when it freezes. The SCR-system will thaw the fluid so that it regains its concentration with maintained quality. The machine will work normally during the time that the fluid melts.

At AdBlue®/DEF temperatures above 20 °C (68 °F) the fluid starts to degrade. Then the fluid gives off ammonia, which is aggressive to materials such as rubber. At temperatures above 75–80 °C (167–176 °F), ammonia production increases. However, high temperatures are permitted for a short time.

AdBlue®/DEF should be stored in a cool, dry, and ventilated place. The fluid may not be stored in direct sunlight. The recommended storage temperature for AdBlue®/DEF is between -11 °C (12 °F) and 25 °C (77 °F). Under these conditions, storage life is approx. two years. Long-term storage of AdBlue®/DEF at a temperature above 25 °C (77 °F) can reduce the lifetime of the fluid. A short time exposure to higher temperatures has no impact on the quality.



## 352 Specifications Fuel system

---

**NOTE!**

If the machine is to be parked for an extended period of time (several months) in ambient temperatures above 40 °C (104 °F) the tank must be drained. This to prevent the fluid from having the wrong quality when starting the machine or that precipitates have a negative impact on the component parts.

**NOTE!**

If the tank has been drained completely it should be rinsed out with new AdBlue®/DEF before new fluid is filled. Never reuse old fluid. If distilled water or ordinary water is used when rinsing there is a risk that the system will generate an alarm due to wrong quality of AdBlue®/DEF.

**NOTE!**

Water of any kind should not be used when cleaning AdBlue®/DEF system or AdBlue®/DEF components since there is a risk that even a small amount of water remains in the system after cleaning. The only exceptions allowed are operations described in the service information made by Volvo.

AdBlue®/DEF is available in plastic container, barrel, IBC, or bulk.

For information on ordering AdBlue®/DEF (only applies to USA-market):

- Volvo Construction Equipment: 1-877-823-1111 (office hours)
- [www.volvoce.com](http://www.volvoce.com) (outside of office hours)

For information on ordering AdBlue®/DEF (other markets), contact your local Volvo dealer.

**Actions in case of contact with AdBlue®/DEF:**

- In case of skin contact, rinse thoroughly with water. The fluid may cause irritation of the skin.
- In case of eye contact, rinse thoroughly for several minutes. If needed, contact a doctor for advice.
- In case of inhalation, breathe fresh air and contact a doctor if needed.
- If swallowed, drink water and contact a doctor.



## Service capacities and change intervals

### Change capacities

Oils and other liquids	Change capacities
Engine oil, including filter	25 litres (6.6 US gal.)
Coolant (main reservoir)	35.8 litres (9.4 US gal.)
Coolant (sub reservoir)	2.2 litres (0.6 US gal.)
Hydraulic tank	126 litres (33 US gal.)
Hydraulic system, total	280 litres (74 US gal.)
Swing gearbox	7 litres (1.8 US gal.)
Track gearbox (each)	5 litres (1.3 US gal.)
Fuel tank	286.5 litres (76 US gal.)
Swing ring gear	20 litres (5.3 US gal.) (18 kg) (39.7 lb)
AdBlue®/DEF tank	25 litres (6.6 US gal.)



354 Specifications  
Service capacities and change intervals

Change intervals

Filter changes

Filter	Hours
Engine oil filter	500
Fuel filter	500
Water separator filter element	500
Air cleaner, primary filter	After cleaning primary filter 5 times or every 2000 hours or maximum 1 year
Air cleaner, secondary filter	After changing primary filter 3 times or every 4000 hours or maximum 2 years
Air conditioner / heater main filter	2000
Cab prefilter	2000
Cartridge of drain filter, hydraulic system	1000 (a)
Return oil filter, hydraulic system	2000 (a) *
Element of servo filter, hydraulic system	1000 (a)
Air ventilation filter, fuel tank	2000
Air breather filter, hydraulic tank	2000
Air breather filter, AdBlue®/DEF tank	6000
AdBlue®/DEF pump unit filter	6000

a) First change: 500 hours

\* When using the hydraulic hammer;

- Frequency of hammer use (50%): change the return oil filter every 1000 hours
- Frequency of hammer use (100%): change the return oil filter every 500 hours



Specifications  
**Service capacities and change intervals**      **355**

**Oil and liquid changes**

Oil/liquid	Hours
Engine oil	500 or maximum 1 year whichever comes first
Coolant	6000 or maximum 4 years whichever comes first
Hydraulic oil (mineral oil)	2000 *
Hydraulic oil (bio oil and long life hydraulic oil)	5000
Swing drive unit oil	1000 (a)
Track drive unit oil	2000 (a)

a) First change: 500 hours

\* When using the hydraulic hammer;

- Frequency of hammer use (50%): change the hydraulic oil every 1000 hours
- Frequency of hammer use (100%): change the hydraulic oil every 600 hours

## Engine

### Engine, specifications

Designation	D6J
Number of cylinders	6
Cylinder bore	98 mm (3.86 in)
Stroke	126 mm (4.96 in)
Displacement	5.70 litres (348 in <sup>3</sup> )
Injection order	1-5-3-6-2-4
Power output at 30 r/s (1800 rpm)	129 kW (177 PS, 173 HP) SAE J1995 Gross
	128 kW (176 PS, 172 HP) ISO 9249 / SAE J1349 Net
Maximum torque	849 Nm (87 kgf m, 626 lbf ft) at 1350 rpm
Low idle	800 rpm
High idle	1900 rpm

### Carbon dioxide emissions

**NOTE!**

Only applicable to engine(s) quipped to meet the legal requirements for exhaust emissions according to EU Stage V.

The table below shows the value of the carbon dioxide (CO<sub>2</sub>) emission determined from EU-type approval testing of parent engine(s) in the warm part of the Non Road Transient Test Cycle (NRTC).

	Test cycle NRTC
Parent engine	With B7 fuel
D6J, CO <sub>2</sub> (g/kWh)	724.0



## Electrical system

System voltage	24 V
Starter	5.5 kW
Batteries	2 x 12 V
Alternator	28 V / 110 A
Horn sound level at 2 m	Min. 115 dB
Head light type	Halogen (70 W) LED (22 W)

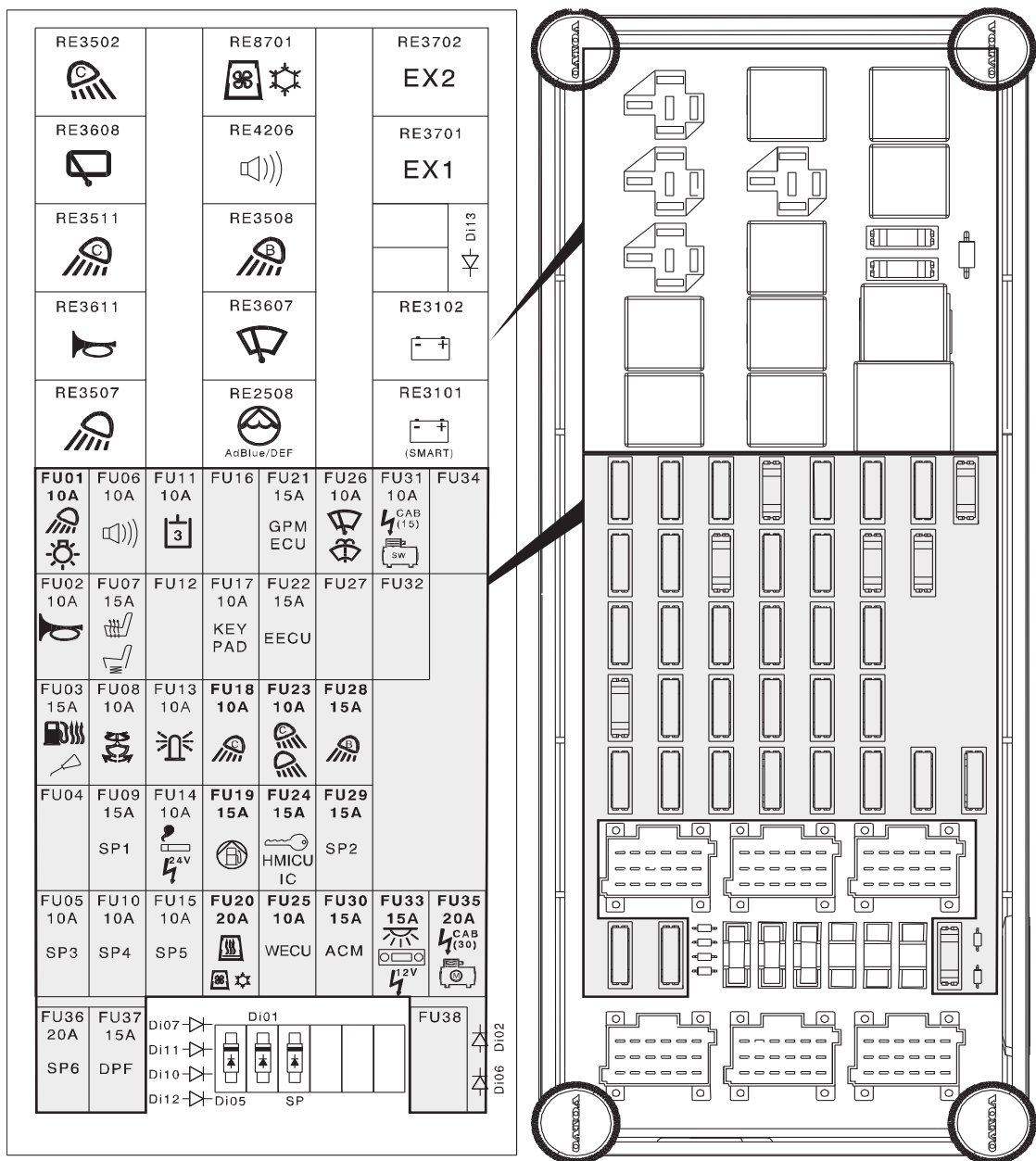



**358**      Specifications  
**Electrical system**

**Relays**

No.	Capacity	Appliance / Circuit
RE3502	Relay	Work light (Counterweight)
RE3608	Relay	Lower wiper
RE3511	Relay	Work light (Cab)
RE3611	Relay	Horn
RE3507	Relay	Work light
RE8701	Relay	Air conditioner
RE4206	Relay	Travel alarm
RE3508	Relay	Work light (Boom)
RE3607	Relay	Upper wiper
RE2508	Relay	AdBlue/DEF
RE3702	Relay	Spare relay
RE3701	Relay	Spare relay
RE3102	Relay	Main 2
RE3101	Relay	Main 1

**Fuses**

No.	Capacity	Appliance / Circuit
FU01	10A	Work light (Boom, Deck)
FU02	10A	Horn
FU03	15A	Water separator heater, Auto lubrication
FU04	-	-
FU05	10A	Spare
FU06	10A	Travel alarm
FU07	15A	Seat heater, Air suspended seat heater
FU08	10A	Tiltrotator
FU09	15A	Spare
FU10	10A	Spare
FU11	10A	Hydraulic option 3
FU12	-	-
FU13	10A	Rotating warning beacon
FU14	10A	Cigarette lighter, Power socket (24V)
FU15	10A	Spare





Specifications  
**Electrical system**      **359**

No.	Capacity	Appliance / Circuit
FU16	-	-
FU17	10A	Keypad
FU18	10A	Work light (Cab)
FU19	15A	Fuel filler pump
FU20	20A	Auxiliary heater, Air conditioner
FU21	15A	GPMECU (General Purpose Machine Electronic Control Unit)
FU22	15A	EMS (Engine Management System)
FU23	10A	Work light (Counterweight)
FU24	15A	Ignition switch, HMICU (Human Machine Interface Control Unit), IC (Instrument Cluster)
FU25	10A	WECU (Telematics ECU)
FU26	10A	Wiper and washer
FU27	-	-
FU28	15A	Work light (Boom)
FU29	15A	Spare
FU30	15A	ACM (Aftertreatment Control Module)
FU31	10A	Power outlet
FU32	-	-
FU33	15A	Interior light, Audio, Power outlet
FU34	-	-
FU35	20A	Power outlet
FU36	20A	Spare
FU37	15A	Diesel Particulate Filter
FU38	-	-



360 Specifications  
Cab

## Cab

### Operator seat

This machine is equipped with an operator seat, which meets the criteria of EN ISO 7096.

### Vibration and sound information

#### Hand-arm vibrations

Weighted root mean square (RMS) acceleration emission of the machine to which the arm is subjected for an 8 hours and at typical operating conditions of the machine equipped with mechanical suspension seat, is as follow. Measuring was carried out according to ISO 5349-1, ISO 5349-2 and ISO 8041 : 1990

- Excavating, mining (quarry), transfer movement and hydraulic breaker application is less than 2.5 m/s<sup>2</sup> A(8)

#### Whole-body vibrations

Weighted root mean square (RMS) acceleration emission of the machine to which the body is subjected for an 8 hours and at typical operating conditions of the machine equipped with mechanical suspension seat, is as follow. Measuring was carried out according to ISO 2631-1 : 1997 and ISO 8041 : 1990

- Excavating, mining (quarry) and hydraulic breaker application is less than 0.5 m/s<sup>2</sup> A(8)
- Transfer movement (traveling) is 0.5 ~ 0.9 m/s<sup>2</sup> A(8)

#### NOTE!

These whole body vibration values was determined at particular operating and terrain conditions and it is therefore not representative for the various conditions in accordance with the intended use of the machine. Consequently this whole body vibration emission value declared by the manufacturer in accordance with European Standard is not intended to determine the whole body vibration exposure to the operator using this machine.

To ensure that the whole-body vibration emission during machine use is kept to a minimum, see page 203.

#### Sound information

Sound pressure level (LpA) at operator position (Measurement according to ISO 6396)	Standard: 71 LpA dB(A) Tropical: 72 LpA dB(A)
Sound power level (LwA) around the machine (Measurement according to 2000/14/EC with applicable appendices and measuring method according to ISO 6395)	Standard: 101 LwA dB(A) Tropical: 102 LwA dB(A)



## Refrigerant

Type	Quantity	GWP <sup>(a)</sup>
R134a	0.8 kg (1.76 lb)	1144 kg CO <sub>2</sub> -eq

a) Global warming potential (GWP) is a measure of how much heat a gas traps in the atmosphere relative to that of carbon dioxide (CO<sub>2</sub>). GWP is calculated in terms of the 100-year warming potential of 1 kg of a greenhouse gas relative to 1 kg of CO<sub>2</sub>.

362 Specifications  
Hydraulic system

## Hydraulic system

Main pump		
Model	K3V112DT	
Maximum flow rate	2 x 207 l/min (2 x 54.6 gpm)	
Type	Variable displacement, axial piston pump	
Servo pump		
Maximum flow	18 l/min (4.8 gpm)	
Relief pressure	3.9 MPa (40 kgf cm <sup>2</sup> , 569 psi)	
Main control valve		
Model	BK28	
Main relief pressure (STD / Boost pressure)	34.3 / 36.3 MPa (350 / 370 kgf cm <sup>2</sup> , 4975 / 5265 psi)	
Port relief pressure	Boom / Dipper arm / Bucket: 37.8 MPa (385 kgf cm <sup>2</sup> , 5483 psi)	
2 stage port relief pressure (Standard)	Low / High: 20.6 / 37.8 MPa (210 / 385 kgf cm <sup>2</sup> , 2988 / 5483 psi)	
Preset relief pressure (Option)	Low / High: 9.8 / 37.8 MPa (100 / 385 kgf cm <sup>2</sup> , 1421 / 5483 psi)	
Control pedals		
Travel pedal	Model	PVD8P
	Stroke	5.5 mm (0.21 in)
	Operating force	10.6 Nm (1.08 kgf m) (7.84 lbf ft)
X1 pedal	Model	RCV8C
	Stroke	5.5 mm (0.21 in)
	Operating force	9.84 Nm (1.0 kgf m) (7.28 lbf ft)



**Specifications**  
**Hydraulic system**      **363**

<b>Control levers</b>		
One button type (Semi-long)	Model	PV48K
	Angle	Forward and backward: 19° Right and left: 25°
	Operating force	Forward and backward: 2.21 Nm (0.23 kgf m) (1.63 lbf ft) Right and left: 2.45 Nm (0.25 kgf m) (1.81 lbf ft)
Four buttons type Three buttons and proportional switch type	Model	PV48K
	Angle	Forward and backward: 19° Right and left: 19°
	Operating force	Forward and backward: 2.02 Nm (0.21 kgf m) (1.49 lbf ft) Right and left: 2.21 Nm (0.23 kgf m) (1.63 lbf ft)

<b>Track motor</b>	
Model	EM140V
Type	Variable displacement axial piston motor with mechanical brake
Relief valve setting pressure	34.3 MPa (350 kgf cm <sup>2</sup> ) (4975 psi)
Brake type	Wet disc, spring applied, hydraulic released
<b>Track gearbox</b>	
Type	2-stage planetary

<b>Swing motor</b>	
Model	M5X130
Type	Fixed displacement axial piston motor with mechanical brake
Relief valve setting pressure	27.9 MPa (285 kgf cm <sup>2</sup> ) (4050 psi)
<b>Swing gearbox</b>	
Type	2-stage planetary

## Machine weights

### Disassembled parts, weight

#### Counterweight, weight

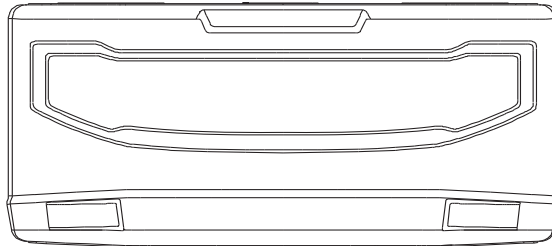

V1148886

Description	Unit	Counterweight
Weight	kg	6200
	lb	13668

#### Boom, weight

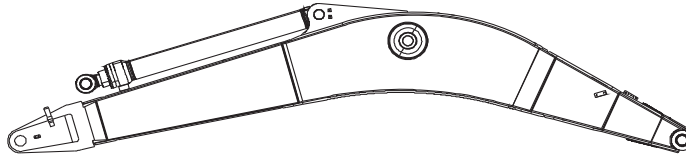

V1068040

Description	Unit	Boom	
		5.7 m (18' 8") GP	5.76 m (18' 10") VA
Weight	kg	2000	2570
	lb	4410	5670

\* Includes cylinder, piping and pin

GP: General Purpose

VA: Variable Adjustable

Dipper arm, weight

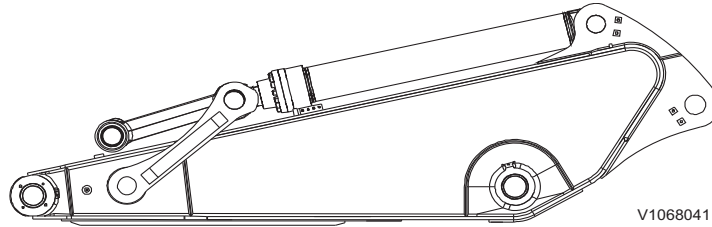

Description	Unit	Dipper arm	
		2.5 m (8' 2") HD	2.9 m (9' 6") GP
Weight	kg lb	975 2150	1000 2200

\* Includes cylinder, linkage and pin

GP: General Purpose

HD: Heavy Duty

Dozer blade, weight

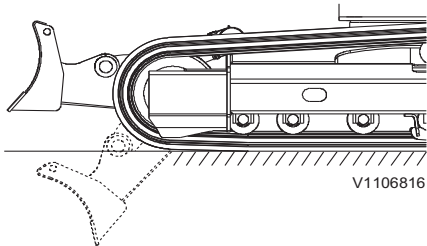

Description	Unit	Dozer blade
Weight	kg lb	790 1742



366 Specifications  
Ground pressure

Ground pressure

<b>ECR235E L</b> GP Boom (m/ft-in): 5.7 / 18' 8" GP Arm (m/ft-in): 2.9 / 9' 6" Bucket (l/kg/lb): 1090 / 908 / 2000 Counterweight (kg/lb): 6200 / 13670				
Description	Shoe width (mm/in)	Operating weight (kg/lb)	Ground pressure (kPa/kgf cm <sup>2</sup> /psi)	Overall width (mm/ft-in)
Triple grouser	600 / 24	24573 / 54180	51.0 / 0.52 / 7.4	2990 / 9'10"
	700 / 28	25039 / 55210	44.1 / 0.45 / 6.4	3090 / 10'2"
	800 / 32	25315 / 55820	39.2 / 0.4 / 5.7	3190 / 10'6"
	900 / 36	25610 / 56470	35.3 / 0.36 / 5.1	3290 / 10'10"
Triple grouser (HD shoe)	600 / 24	25779 / 56840	53.0 / 0.54 / 7.7	2990 / 9'10"
Double grouser	700 / 28	25298 / 55780	45.1 / 0.46 / 6.5	3090 / 10'2"
Rubber pad	600 / 24	24700 / 54460	51.0 / 0.52 / 7.4	2990 / 9'10"
Add on rubber	600 / 24	25296 / 55780	52.0 / 0.53 / 7.5	2990 / 9'10"
<b>ECR235E L</b> GP Boom (m/ft-in): 5.7 / 18' 8" HD Arm (m/ft-in): 2.5 / 8' 2" Bucket (l/kg/lb): 1090 / 908 / 2000 Counterweight (kg/lb): 6200 / 13670				
Description	Shoe width (mm/in)	Operating weight (kg/lb)	Ground pressure (kPa/kgf cm <sup>2</sup> /psi)	Overall width (mm/ft-in)
Triple grouser	600 / 24	24518 / 54060	51.0 / 0.52 / 7.4	2990 / 9'10"
	700 / 28	24984 / 55090	44.1 / 0.45 / 6.4	3090 / 10' 2"
	800 / 32	25260 / 55700	39.2 / 0.4 / 5.7	3190 / 10'6"
	900 / 36	25555 / 56350	35.3 / 0.36 / 5.1	3290 / 10'10"
Triple grouser (HD shoe)	600 / 24	24686 / 54430	51.0 / 0.52 / 7.4	2990 / 9'10"
Double grouser	700 / 28	25243 / 55660	45.1 / 0.46 / 6.5	3090 / 10'2"
Rubber pad	600 / 24	24813 / 54710	51.0 / 0.52 / 7.4	2990 / 9'10"
Add on rubber	600 / 24	25409 / 56030	53.0 / 0.54 / 7.7	2990 / 9"10"

GP : General Purpose  
 HD : Heavy Duty





Specifications  
**Ground pressure**      **367**

**ECR235E L**  
**VA Boom (m/ft-in): 5.76 / 18' 10"**  
**GP Arm (m/ft-in): 2.9 / 9' 6"**  
**Bucket (l/kg/lb): 1090 / 908 / 2000**  
**Counterweight (kg/lb): 6200 / 13670**

Description	Shoe width (mm/in)	Operating weight (kg/lb)	Ground pressure (kPa/kgf cm <sup>2</sup> /psi)	Overall width (mm/ft-in)
Triple grouser	600 / 24	25138 / 55430	52.0 / 0.53 / 7.5	2990 / 9'10"
	700 / 28	25604 / 56460	45.1 / 0.46 / 6.5	3090 / 10'2"
	800 / 32	25881 / 57070	40.2 / 0.41 / 6.5	3190 / 10'6"
	900 / 36	26176 / 57720	36.3 / 0.37 / 5.3	3290 / 10'10"
Triple grouser (HD shoe)	600 / 24	25307 / 55800	52.0 / 0.53 / 7.5	2990 / 9'10"
Double grouser	700 / 28	25863 / 57030	46.1 / 0.47 / 6.7	3090 / 10'2"
Rubber pad	600 / 24	25434 / 56080	53.0 / 0.54 / 7.7	2990 / 9'10"
Add on rubber	600 / 24	26030 / 57400	53.9 / 0.55 / 7.8	2990 / 9'10"

**ECR235E L**  
**VA Boom (m/ft-in): 5.76 / 18' 10"**  
**HD Arm (m/ft-in): 2.5 / 8' 2"**  
**Bucket (l/kg/lb): 1090 / 908 / 2000**  
**Counterweight (kg/lb): 6200 / 13670**

Description	Shoe width (mm/in)	Operating weight (kg/lb)	Ground pressure (kPa/kgf cm <sup>2</sup> /psi)	Overall width (mm/ft-in)
Triple grouser	600 / 24	25083 / 55310	52.0 / 0.53 / 7.5	2990 / 9'10"
	700 / 28	25549 / 56340	45.1 / 0.46 / 6.5	3090 / 10'2"
	800 / 32	25826 / 56950	40.2 / 0.41 / 5.8	3190 / 10'6"
	900 / 36	26121 / 57600	36.3 / 0.37 / 5.3	3290 / 10'10"
Triple grouser (HD shoe)	600 / 24	25252 / 55680	52.0 / 0.53 / 7.5	2990 / 9'10"
Double grouser	700 / 28	25808 / 56910	46.1 / 0.47 / 6.7	3090 / 10'2"
Rubber pad	600 / 24	25379 / 55960	53.0 / 0.54 / 7.7	2990 / 9'10"
Add on rubber	600 / 24	25975 / 57280	53.9 / 0.55 / 7.8	2990 / 9'10"

**GP : General Purpose**  
**VA : Variable Adjustable**  
**HD : Heavy Duty**



**368 Specifications**  
**Ground pressure**

<b>ECR235E L with dozer blade</b> GP Boom (m/ft-in): 5.7 / 18' 8" GP Arm (m/ft-in): 2.9 / 9' 6" Bucket (l/kg/lb): 1090 / 908 / 2000 Counterweight (kg/lb): 6200 / 13670				
Description	Shoe width (mm/in)	Operating weight (kg/lb)	Ground pressure (kPa/kgf cm <sup>2</sup> /psi)	Overall width (mm/ft-in)
Triple grouser	600 / 24	25955 / 57230	53.9 / 0.55 / 7.8	2990 / 9'10"
	700 / 28	26436 / 58290	47.1 / 0.48 / 6.8	3090 / 10'2"
	800 / 32	26727 / 58930	41.2 / 0.42 / 6.0	3190 / 10'6"
	900 / 36	27022 / 59580	37.3 / 0.38 / 5.4	3290 / 10'10"
Triple grouser (HD shoe)	600 / 24	27161 / 59890	55.9 / 0.57 / 8.1	2990 / 9'10"
Double grouser	700 / 28	26695 / 58860	47.1 / 0.48 / 6.8	3090 / 10'2"
Rubber pad	600 / 24	26082 / 57510	53.9 / 0.55 / 7.8	2990 / 9'10"
Add on rubber	600 / 24	26679 / 58830	54.9 / 0.56 / 8.0	2990 / 9'10"

<b>ECR235E L with dozer blade</b> GP Boom (m/ft-in): 5.7 / 18' 8" HD Arm (m/ft-in): 2.5 / 8' 2" Bucket (l/kg/lb): 1090 / 908 / 2000 Counterweight (kg/lb): 6200 / 13670				
Description	Shoe width (mm/in)	Operating weight (kg/lb)	Ground pressure (kPa/kgf cm <sup>2</sup> /psi)	Overall width (mm/ft-in)
Triple grouser	600 / 24	25900 / 57110	53.9 / 0.55 / 7.8	2990 / 9'10"
	700 / 28	26381 / 58170	47.1 / 0.48 / 6.8	3090 / 10'2"
	800 / 32	26672 / 58810	41.2 / 0.42 / 6.0	3190 / 10'6"
	900 / 36	26967 / 59460	37.3 / 0.38 / 5.4	3290 / 10'10"
Triple grouser (HD shoe)	600 / 24	26069 / 57480	53.9 / 0.55 / 7.8	2990 / 9'10"
Double grouser	700 / 28	26640 / 58740	47.1 / 0.48 / 6.8	3090 / 10'2"
Rubber pad	600 / 24	26196 / 57760	53.9 / 0.55 / 7.8	2990 / 9'10"
Add on rubber	600 / 24	26792 / 59080	55.9 / 0.57 / 8.1	2990 / 9'10"

**GP : General Purpose**  
**HD : Heavy Duty**



Specifications  
**Ground pressure**      **369**

**ECR235E L with dozer blade**  
**VA Boom (m/ft-in): 5.76 / 18' 10"**  
**GP Arm (m/ft-in): 2.9 / 9' 6"**  
**Bucket (l/kg/lb): 1090 / 908 / 2000**  
**Counterweight (kg/lb): 6200 / 13670**

Description	Shoe width (mm/in)	Operating weight (kg/lb)	Ground pressure (kPa/kgf cm <sup>2</sup> /psi)	Overall width (mm/ft-in)
Triple grouser	600 / 24	26521 / 58480	54.9 / 0.56 / 8.0	2990 / 9'10"
	700 / 28	27001 / 59540	48.0 / 0.49 / 7.0	3090 / 10'2"
	800 / 32	27293 / 60180	42.2 / 0.43 / 6.1	3190 / 10'6"
	900 / 36	27588 / 60830	38.2 / 0.39 / 5.5	3290 / 10'10"
Triple grouser (HD shoe)	600 / 24	26689 / 58850	54.9 / 0.56 / 8.0	2990 / 9'10"
Double grouser	700 / 28	27260 / 60110	48.0 / 0.49 / 7.0	3090 / 10'2"
Rubber pad	600 / 24	26816 / 59130	55.9 / 0.57 / 8.1	2990 / 9'10"
Add on rubber	600 / 24	27413 / 60450	56.9 / 0.58 / 8.2	2990 / 9'10"

**ECR235E L with dozer blade**  
**VA Boom (m/ft-in): 5.76 / 18' 10"**  
**HD Arm (m/ft-in): 2.5 / 8' 2"**  
**Bucket (l/kg/lb): 1090 / 908 / 2000**  
**Counterweight (kg/lb): 6200 / 13670**

Description	Shoe width (mm/in)	Operating weight (kg/lb)	Ground pressure (kPa/kgf cm <sup>2</sup> /psi)	Overall width (mm/ft-in)
Triple grouser	600 / 24	26466 / 58360	54.9 / 0.56 / 8.0	2990 / 9'10"
	700 / 28	26946 / 59420	48.0 / 0.49 / 7.0	3090 / 10'2"
	800 / 32	27238 / 60060	42.2 / 0.43 / 6.1	3190 / 10'6"
	900 / 36	27533 / 60710	38.2 / 0.39 / 5.5	3290 / 10'10"
Triple grouser (HD shoe)	600 / 24	26634 / 58730	54.9 / 0.56 / 8.0	2990 / 9'10"
Double grouser	700 / 28	27205 / 59990	48.0 / 0.49 / 7.0	3090 / 10'2"
Rubber pad	600 / 24	26761 / 59010	55.9 / 0.57 / 8.1	2990 / 9'10"
Add on rubber	600 / 24	27358 / 60320	56.9 / 0.58 / 8.2	2990 / 9'10"

**GP : General Purpose**  
**VA : Variable Adjustable**  
**HD : Heavy Duty**

370 Specifications  
Dimensions

Dimensions

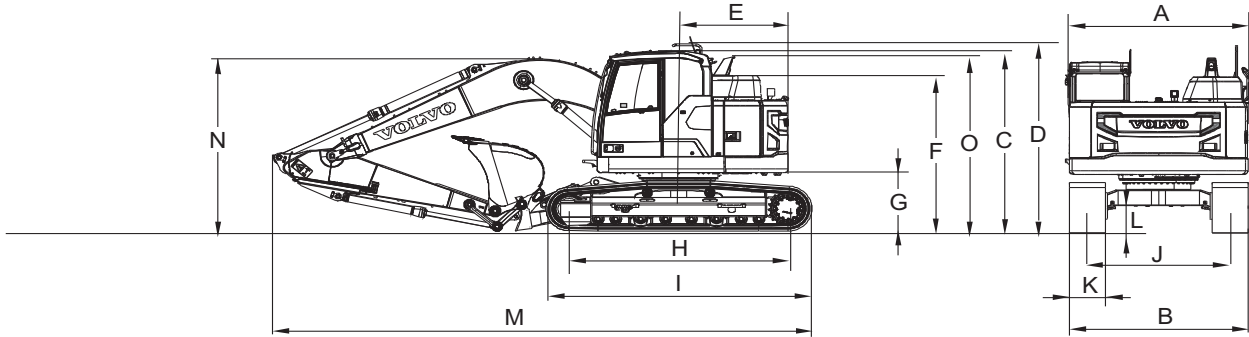

V1154321

Description	Unit	GP Boom	
		5.7 m (18' 8")	
		Dipper arm	
		2.5 m (8' 2")	2.9 m (9' 6")
A. Overall width of superstructure	mm ft-in	2990 (9'10")	2990 (9'10")
B. Overall width		3090 (10'2")	3090 (10'2")
C. Overall height of cab		2965 (9'9")	2965 (9'9")
D. Overall height of guardrail (unfolded)		3365 (11'0")	3365 (11'0")
D. Overall height of guardrail (folded)		2925 (9'7")	2925 (9'7")
E. Tail swing radius		1810 (5'11")	1810 (5'11")
F. Overall height of engine hood		2780 (9'1")	2780 (9'1")
G. *Counterweight clearance		1025 (3'4")	1025 (3'4")
H. Tumbler length		3660 (12'0")	3660 (12'0")
I. Track length		4460 (14'8")	4460 (14'8")
J. Track gauge		2390 (7'10")	2390 (7'10")
K. Shoe width		mm in	700 (2'4")
L. *Minimum ground clearance	mm ft-in	460 (1'6")	460 (1'6")
M. Overall length		9070 (29'9")	9010 (29'7")
N. Overall height of boom		3330 (10'11")	3190 (10'6")
O. Overall height of diffuser		3035 (9' 11")	3035 (9' 11")

\* Without shoe grouser



Specifications  
Dimensions 371

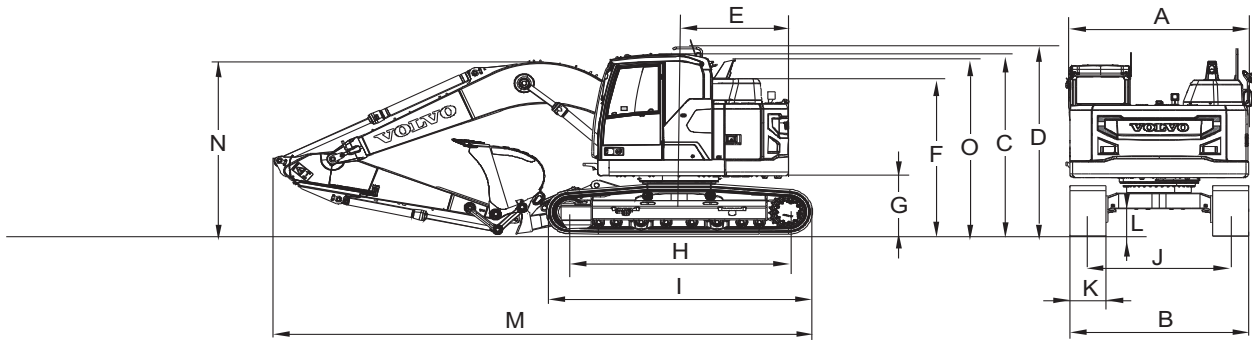

V1154321

Description	Unit	VA Boom	
		5.76 m (18' 10")	
		Dipper arm	
		2.5 m (8' 2")	2.9 m (9' 6")
A. Overall width of superstructure	mm ft-in	2990 (9'10")	2990 (9'10")
B. Overall width		3090 (10'2")	3090 (10'2")
C. Overall height of cab		2965 (9'9")	2965 (9'9")
D. Overall height of guardrail (unfolded)		3365 (11'0")	3365 (11'0")
D. Overall height of guardrail (folded)		2925 (9'7")	2925 (9'7")
E. Tail swing radius		1810 (5'11")	1810 (5'11")
F. Overall height of engine hood		2780 (9'1")	2780 (9'1")
G. *Counterweight clearance		1025 (3'4")	1025 (3'4")
H. Tumbler length		3660 (12'0")	3660 (12'0")
I. Track length		4460 (14'8")	4460 (14'8")
J. Track gauge		2390 (7'10")	2390 (7'10")
K. Shoe width		mm in	700 (2'4")
L. *Minimum ground clearance	mm ft-in	460 (1'6")	460 (1'6")
M. Overall length		9090 (29'10")	9065 (29'9")
N. Overall height of boom		3060 (10'0")	3030 (9'11")
O. Overall height of diffuser		3035 (9'11")	3035 (9' 11")

\* Without shoe grouser

372 Specifications  
Dimensions

Dozer blade, dimension

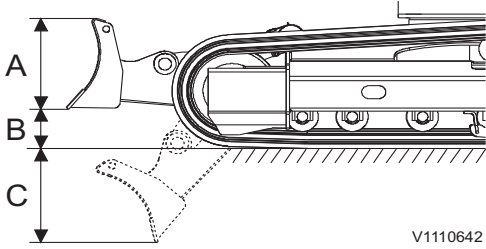

Description	Unit	Dozer blade
A. Height	mm ft-in	600 2'0"
A. Width with 600 mm shoe		2990 9'10"
A. Width with 700 mm shoe		3090 10'2"
A. Width with 800 mm shoe		3190 10'6"
B. Lift height		610 2'0"
C. Digging depth		480 1'7"

### Boom and dipper arm

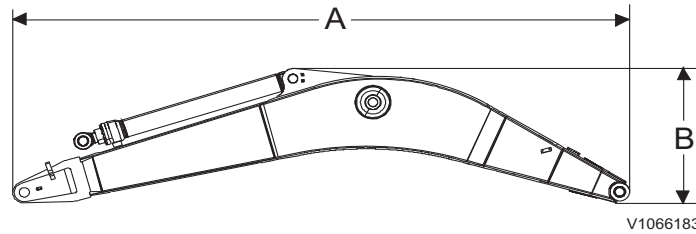

Description	Unit	Boom	
		5.7 m (18' 8") GP	5.76 m (18' 10") VA
Length (A)	mm ft in	5910 19'5"	5965 19'7"
Height (B)		1770 5'10"	1300 4'3"
Width		670 2'2"	670 2'2"

\* Includes dipper arm cylinder, piping and pin  
GP: General Purpose  
VA: Variable Adjustable

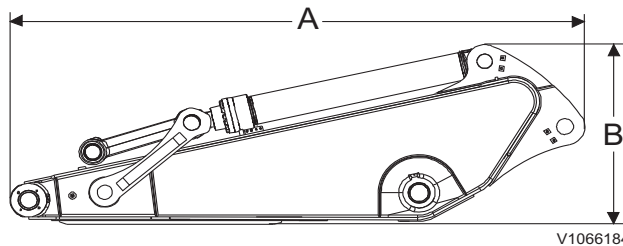

Description	Unit	Dipper arm	
		2.5 m (8' 2") HD	2.9 m (9' 6") GP
Length (A)	mm ft in	3525 11'7"	3910 12'10"
Height (B)		860 2'10"	860 2'10"
Width		440 1'5"	440 1'5"

\* Includes bucket cylinder, linkage and pin  
GP: General Purpose  
HD: Heavy Duty

374 Specifications  
Working ranges

## Working ranges

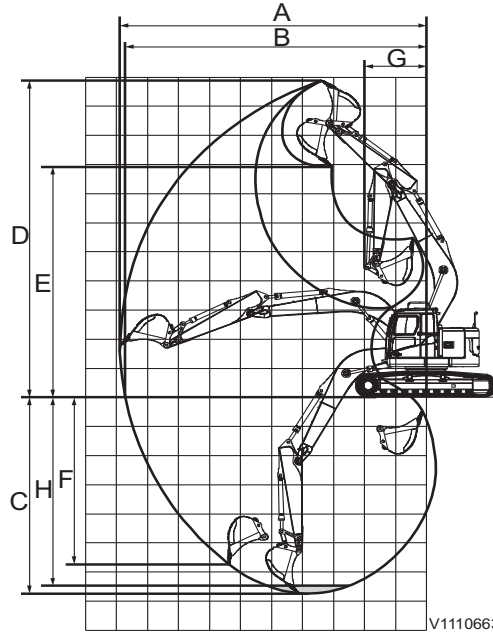

V1110663

Description	Unit	Boom	
		5.7 m (18' 8")	
		Dipper arm	
		2.5 m (8' 2")	2.9 m (9' 6")
A. Maximum digging reach	mm ft in	9510 31'2"	9890 32'5"
B. Maximum digging reach on ground		9340 30'8"	9735 31'11"
C. Maximum digging depth		6350 20'10"	6755 22'2"
D. Maximum cutting height		10600 34'9"	10915 35'10"
E. Maximum dumping height		7560 24'10"	7870 25'10"
F. Maximum vertical wall digging depth		5220 17'2"	5685 18'8"
G. Minimum front swing radius		2395 7'10"	2170 7'1"
H. Maximum digging depth (level the ground of 2.44 m (8'))		6120 20'1"	6550 21'6"

- Machine with direct fit bucket



Specifications  
Working ranges **375**

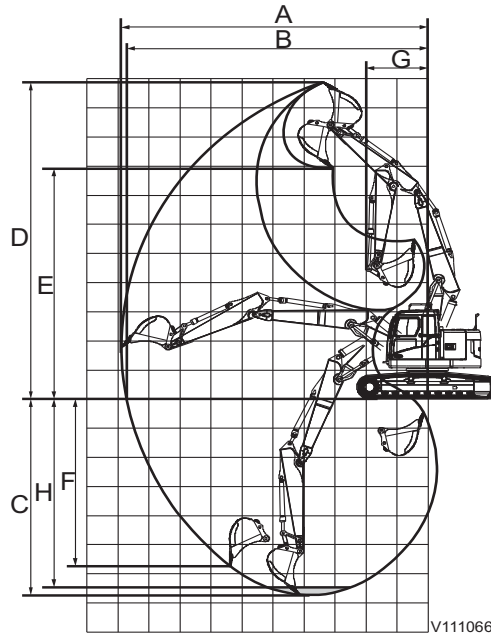

V1110664

Description	Unit	Variable adjustable boom	
		5.76 m (18' 10")	
		Dipper arm	
		2.5 m (8' 2")	2.9 m (9' 6")
A. Maximum digging reach	mm ft in	9690 31'9"	10085 33'1"
B. Maximum digging reach on ground		9660 31'8"	9930 32'7"
C. Maximum digging depth		5950 19'6"	6355 20'10"
D. Maximum cutting height		11150 36'7"	11515 37'9"
E. Maximum dumping height		8095 26'7"	8460 27'9"
F. Maximum vertical wall digging depth		4910 16'1"	5325 17'6"
G. Minimum front swing radius		2235 7'4"	2160 7'1"
H. Maximum digging depth (level the ground of 2.44 m (8'))		5840 19'2"	6250 20'6"

- Machine with direct fit bucket



Specifications  
376 Recommended bucket sizes

## Recommended bucket sizes

### Maximum permitted buckets

Shoe: 600 mm with 6200 kg counterweight					
For direct-fit buckets	Unit	Boom			
		5.7 m (18' 8")		5.76 m (18' 10")	
		Dipper arm		Dipper arm	
		2.5 m (8' 2")	2.9 m (9' 6")	2.5 m (8' 2")	2.9 m (9' 6")
GP bucket 1.5 t/m <sup>3</sup>	l / kg	1500/1250	1400/1150	1425/1200	1325/1100
GP bucket 1.8 t/m <sup>3</sup>		1350/1150	1225/1050	1275/1050	1175/1000
HD bucket 1.8 t/m <sup>3</sup>		1250/1250	1175/1150	1200/1200	1125/1100
HD bucket 2.0 t/m <sup>3</sup>		1175/1150	1100/1100	1125/1100	1050/1050

Shoe: 600 mm with 6200 kg counterweight					
For universal quick coupler buckets	Unit	Boom			
		5.7 m (18' 8")		5.76 m (18' 10")	
		Dipper arm		Dipper arm	
		2.5 m (8' 2")	2.9 m (9' 6")	2.5 m (8' 2")	2.9 m (9' 6")
GP bucket 1.5 t/m <sup>3</sup>	l / kg	1350/1150	1250/1050	1275/1100	1175/1000
GP bucket 1.8 t/m <sup>3</sup>		1200/1000	1100/900	1150/950	1050/850
HD bucket 1.8 t/m <sup>3</sup>		1125/1100	1050/1050	1075/1050	1000/1000
HD bucket 2.0 t/m <sup>3</sup>		1050/1050	975/950	1000/1000	925/900

Shoe: 600 mm with 6200 kg counterweight					
For S1 quick coupler buckets	Unit	Boom			
		5.7 m (18' 8")		5.76 m (18' 10")	
		Dipper arm		Dipper arm	
		2.5 m (8' 2")	2.9 m (9' 6")	2.5 m (8' 2")	2.9 m (9' 6")
GP bucket 1.5 t/m <sup>3</sup>	l / kg	1400/1200	1300/1100	1325/1100	1225/1050
GP bucket 1.8 t/m <sup>3</sup>		1250/1050	1150/950	1175/1000	1100/900
HD bucket 1.8 t/m <sup>3</sup>		1175/1150	1075/1050	1125/1100	1025/1000
HD bucket 2.0 t/m <sup>3</sup>		1100/1100	1000/1000	1050/1050	950/950

**NOTE!**

Bucket size based on ISO 7451, heaped material with a 1:1 angle of repose.

**NOTE!**

"Maximum permitted sizes" are for reference only and are not necessarily available from the factory.

**NOTE!**

Bucket widths are less than bucket's tip radius.



Specifications  
**Recommended bucket sizes 377**

Shoe: 700 mm with 6200 kg counterweight					
For direct-fit buckets	Unit	Boom			
		5.7 m (18' 8")		5.76 m (18' 10")	
		Dipper arm		Dipper arm	
		2.5 m (8' 2")	2.9 m (9' 6")	2.5 m (8' 2")	2.9 m (9' 6")
GP bucket 1.5 t/m <sup>3</sup>	l / kg	1550/1300	1425/1200	1450/1200	1350/1150
GP bucket 1.8 t/m <sup>3</sup>		1375/1150	1275/1050	1300/1100	1200/1000
HD bucket 1.8 t/m <sup>3</sup>		1300/1300	1200/1200	1225/1200	1125/1100
HD bucket 2.0 t/m <sup>3</sup>		1200/1200	1125/1100	1150/1150	1050/1050

Shoe: 700 mm with 6200 kg counterweight					
For universal quick coupler buckets	Unit	Boom			
		5.7 m (18' 8")		5.76 m (18' 10")	
		Dipper arm		Dipper arm	
		2.5 m (8' 2")	2.9 m (9' 6")	2.5 m (8' 2")	2.9 m (9' 6")
GP bucket 1.5 t/m <sup>3</sup>	l / kg	1400/1150	1275/1100	1300/1100	1200/1000
GP bucket 1.8 t/m <sup>3</sup>		1225/1050	1150/950	1150/950	1075/900
HD bucket 1.8 t/m <sup>3</sup>		1175/1150	1075/1050	1100/1100	1000/1000
HD bucket 2.0 t/m <sup>3</sup>		1100/1100	1000/1000	1025/1000	950/950

Shoe: 700 mm with 6200 kg counterweight					
For S1 quick coupler buckets	Unit	Boom			
		5.7 m (18' 8")		5.76 m (18' 10")	
		Dipper arm		Dipper arm	
		2.5 m (8' 2")	2.9 m (9' 6")	2.5 m (8' 2")	2.9 m (9' 6")
GP bucket 1.5 t/m <sup>3</sup>	l / kg	1450/1200	1325/1100	1350/1150	1250/1050
GP bucket 1.8 t/m <sup>3</sup>		1275/1050	1175/1100	1200/1000	1100/950
HD bucket 1.8 t/m <sup>3</sup>		1200/1200	1125/1100	1150/1150	1050/1050
HD bucket 2.0 t/m <sup>3</sup>		1125/1100	1050/1050	1050/1050	975/950

**NOTE!**

Bucket size based on ISO 7451, heaped material with a 1:1 angle of repose.

**NOTE!**

"Maximum permitted sizes" are for reference only and are not necessarily available from the factory.

**NOTE!**

Bucket widths are less than bucket's tip radius.



378 Specifications  
Digging forces

**Digging forces**

Description		Unit	Boom	
			5.7 m (18' 8")	
			Dipper arm	
			2.5 m (8' 2")	2.9 m (9' 6")
Bucket radius		mm in	1528 60"	1528 60"
Breakout force	Normal, SAE	kN	125	125
		kg	12752	12756
		lb	28090	28100
	Power boost, SAE	kN	132	132
kg lb		13480 29700	13484 29710	
Breakout force	Normal, ISO	kN	141	141
		kg	14417	14422
		lb	31760	31770
	Power boost, ISO	kN	149	149
kg lb		15241 33580	15245 33590	
Tearout force	Normal, SAE	kN	117	101
		kg	11962	10339
		lb	26350	22780
	Power boost, SAE	kN	123	107
kg lb		12645 27860	10930 24080	
Tearout force	Normal, ISO	kN	120	103
		kg	12312	10605
		lb	27130	23360
	Power boost, ISO	kN	127	109
kg lb		13016 28680	11211 24700	
Rotation angle, bucket		deg.(°)	175	175



Specifications  
**Digging forces**      **379**

Description		Unit	Variable adjustable boom	
			5.76 m (18' 10")	
			Dipper arm	
			2.5 m (8' 2")	2.9 m (9' 6")
Bucket radius		mm in	1525 60"	1525 60"
Breakout force	Normal, SAE	kN	125	125
		kg	12752	12756
		lb	28090	28100
	Power boost, SAE	kN	132	132
		kg	13480	13484
		lb	29700	29710
Breakout force	Normal, ISO	kN	141	141
		kg	14417	14422
		lb	31760	31770
	Power boost, ISO	kN	149	149
		kg	15241	15245
		lb	33580	33590
Tearout force	Normal, SAE	kN	117	101
		kg	11962	10339
		lb	26350	22780
	Power boost, SAE	kN	123	107
		kg	12645	10930
		lb	27860	24080
Tearout force	Normal, ISO	kN	120	103
		kg	12312	10605
		lb	27130	23360
	Power boost, ISO	kN	127	109
		kg	13016	11211
		lb	28680	24700
Rotation angle, bucket		deg.(°)	175	175

380 Specifications  
Lifting capacities

Lifting capacities

For Europe

	H	1.5 m		3.0 m		4.5 m		6.0 m		7.5 m		Max. Reach		
														Max.
		kg	kg	kg	kg	kg	kg	kg	kg	kg	kg	kg	kg	m
<b>Boom: 5.7 m Dipper arm: 2.5 m Shoe: 600 mm Counterweight: 6200 kg Without D/Blade</b>	9 m	-	-	*8380	*8380	-	-	-	-	-	-	*8380	*8380	3.12
	7.5 m	-	-	-	-	*6890	*6890	-	-	-	-	*6680	6240	5.46
	6 m	-	-	-	-	*7210	*7210	*6880	5370	-	-	*6230	4430	6.72
	4.5 m	-	-	*11790	*11790	*8700	8140	*7430	5210	-	-	5800	3660	7.47
	3 m	-	-	-	-	*10880	7550	8030	4970	5670	3550	5260	3290	7.87
	1.5 m	-	-	-	-	12280	7050	7760	4730	5550	3440	5070	3150	7.96
	0 m	-	-	-	-	11980	6810	7580	4560	5470	3360	5190	3200	7.77
	-1.5 m	-	-	*11650	*11650	11920	6760	7510	4500	-	-	5700	3490	7.26
	-3 m	-	-	*15910	13350	*11700	6840	7580	4560	-	-	6960	4230	6.36
-4.5 m	-	-	*11740	*11740	*8570	7110	-	-	-	-	*7760	6380	4.85	
<b>Boom: 5.7 m Dipper arm: 2.9 m Shoe: 600 mm Counterweight: 6200 kg Without D/Blade</b>	9 m	-	-	-	-	-	-	-	-	-	-	*5830	*5830	4.03
	7.5 m	-	-	-	-	*6150	*6150	*4920	*4920	-	-	*4830	*4830	6.02
	6 m	-	-	-	-	*6530	*6530	*6380	5430	-	-	*4530	4000	7.18
	4.5 m	-	-	*10230	*10230	*8010	*8010	*7000	5260	5810	3680	*4490	3370	7.88
	3 m	-	-	-	-	*10230	7670	*8000	5000	5690	3570	*4650	3050	8.26
	1.5 m	-	-	-	-	*12250	7130	7790	4740	5550	3440	4720	2930	8.35
	0 m	-	-	*6180	*6180	11990	6810	7570	4550	5450	3340	4810	2960	8.17
	-1.5 m	*6750	*6750	*10980	*10980	11870	6710	7470	4470	5400	3300	5220	3200	7.68
	-3 m	*11760	*11760	*17000	13180	11930	6760	7500	4490	-	-	6200	3780	6.84
-4.5 m	-	-	*13310	*13310	*9670	6960	-	-	-	-	*7590	5280	5.47	
<b>Boom: 5.7 m Dipper arm: 2.5 m Shoe: 600 mm Counterweight: 6200 kg D/Blade Down</b>	9 m	-	-	*8380	*8380	-	-	-	-	-	-	*8380	*8380	3.12
	7.5 m	-	-	-	-	*6890	*6890	-	-	-	-	*6680	*6680	5.46
	6 m	-	-	-	-	*7210	*7210	*6880	5940	-	-	*6230	4920	6.72
	4.5 m	-	-	*11790	*11790	*8700	*8700	*7430	5790	-	-	*6200	4080	7.47
	3 m	-	-	-	-	*10880	8440	*8380	5540	*7220	3980	*6460	3690	7.87
	1.5 m	-	-	-	-	*12700	7940	*9290	5300	*7610	3860	*7010	3540	7.96
	0 m	-	-	-	-	*13390	7690	*9820	5130	*7790	3780	*7490	3600	7.77
	-1.5 m	-	-	*11650	*11650	*13040	7630	*9720	5070	-	-	*7740	3930	7.26
	-3 m	-	-	*15910	15230	*11700	7720	*8660	5130	-	-	*7950	4750	6.36
-4.5 m	-	-	*11740	*11740	*8570	7990	-	-	-	-	*7760	7160	4.85	
<b>Boom: 5.7 m Dipper arm: 2.9 m Shoe: 600 mm Counterweight: 6200 kg D/Blade Down</b>	9 m	-	-	-	-	-	-	-	-	-	-	*5830	*5830	4.03
	7.5 m	-	-	-	-	*6150	*6150	*4920	*4920	-	-	*4830	*4830	6.02
	6 m	-	-	-	-	*6530	*6530	*6380	6010	-	-	*4530	4450	7.18
	4.5 m	-	-	*10230	*10230	*8010	*8010	*7000	5840	*6170	4100	*4490	3770	7.88
	3 m	-	-	-	-	*10230	8570	*8000	5580	*6940	3990	*4650	3420	8.26
	1.5 m	-	-	-	-	*12250	8010	*9020	5320	*7410	3860	*4990	3290	8.35
	0 m	-	-	*6180	*6180	*13250	7690	*9680	5120	*7720	3760	*5610	3340	8.17
	-1.5 m	*6750	*6750	*10980	*10980	*13190	7590	*9770	5030	*7580	3720	*6740	3610	7.68
	-3 m	*11760	*11760	*17000	15060	*12150	7640	*9040	5060	-	-	*7560	4250	6.84
-4.5 m	-	-	*13310	*13310	*9670	7840	-	-	-	-	*7590	5940	5.47	

: Along undercarriage, : Across undercarriage, H : Lifting hook related to ground level

1. Machine in "Fine Mode-F" (Power Boost), for lifting capacities.
2. The above loads are in compliance with SAE and ISO Hydraulic Excavator Lift Capacity Standards.
3. Rated loads do not exceed 87% of hydraulic lifting capacity or 75% of tipping load.
4. Rated loads marked with an asterisk ( \* ) are limited by hydraulic capacity rather than tipping load.



**Specifications**  
**Lifting capacities**      **381**

	H	1.5 m		3.0 m		4.5 m		6.0 m		7.5 m		Max. Reach		
														Max.
		kg	kg	kg	kg	kg	kg	kg	kg	kg	kg	kg	kg	m
<b>Boom: 5.76 m</b> <b>Dipper arm: 2.5 m</b> <b>Shoe: 600 mm</b> <b>Counterweight: 6200 kg</b> <b>Without D/Blade</b>	9 m	-	-	*9840	*9840	-	-	-	-	-	-	*8670	*8670	3.57
	7.5 m	-	-	*8290	*8290	*8730	8620	-	-	-	-	*6830	5680	5.73
	6 m	-	-	*7680	*7680	*8800	8480	8460	5290	-	-	*6280	4120	6.93
	4.5 m	-	-	-	-	*11340	8030	8270	5130	5740	3580	5530	3440	7.67
	3 m	-	-	-	-	*12760	7400	7980	4870	5640	3480	5040	3110	8.05
	1.5 m	-	-	-	-	12180	6900	7710	4630	5520	3380	4880	2990	8.14
	0 m	-	-	-	-	11920	6690	7540	4480	5440	3310	5010	3060	7.95
	-1.5 m	-	-	*9780	*9780	*10700	6680	7500	4440	-	-	5500	3340	7.46
	-3 m	-	-	-	-	*7710	6810	*5820	4530	-	-	-	-	6.59
<b>Boom: 5.76 m</b> <b>Dipper arm: 2.9 m</b> <b>Shoe: 600 mm</b> <b>Counterweight: 6200 kg</b> <b>Without D/Blade</b>	9 m	-	-	*7890	*7890	-	-	-	-	-	-	*5990	*5990	4.41
	7.5 m	-	-	-	-	*7010	*7010	*5930	5360	-	-	*4920	*4920	6.28
	6 m	-	-	*6060	*6060	*7010	*7010	*7170	5360	-	-	*4550	3730	7.40
	4.5 m	-	-	*9910	*9910	*9130	8160	8340	5180	5780	3610	*4440	3160	8.09
	3 m	-	-	-	-	*12360	7530	8030	4910	5660	3500	*4520	2880	8.45
	1.5 m	-	-	-	-	12270	6970	7730	4640	5520	3370	4540	2770	8.54
	0 m	-	-	-	-	11920	6680	7530	4460	5420	3280	4640	2820	8.36
	-1.5 m	-	-	*9410	*9410	*11330	6620	7450	4400	5400	3260	5040	3060	7.89
	-3 m	-	-	-	-	*8660	6720	*6620	4450	-	-	*4660	3600	7.07
<b>Boom: 5.76 m</b> <b>Dipper arm: 2.5 m</b> <b>Shoe: 600 mm</b> <b>Counterweight: 6200 kg</b> <b>D/Blade Down</b>	9 m	-	-	*9840	*9840	-	-	-	-	-	-	*8670	*8670	3.57
	7.5 m	-	-	*8290	*8290	*8730	*8730	-	-	-	-	*6830	6310	5.73
	6 m	-	-	*7680	*7680	*8800	*8800	*8660	5880	-	-	*6280	4590	6.93
	4.5 m	-	-	-	-	*11340	8930	*9040	5710	*7290	4000	*6140	3850	7.67
	3 m	-	-	-	-	*12760	8300	*9570	5450	*7760	3910	*6280	3500	8.05
	1.5 m	-	-	-	-	*13350	7790	*9840	5200	*7710	3800	*6680	3370	8.14
	0 m	-	-	-	-	*12570	7570	*9490	5050	*7210	3730	*6450	3450	7.95
	-1.5 m	-	-	*9780	*9780	*10700	7560	*8290	5010	-	-	*5810	3770	7.46
	-3 m	-	-	-	-	*7710	7700	*5820	5110	-	-	-	-	6.59
<b>Boom: 5.76 m</b> <b>Dipper arm: 2.9 m</b> <b>Shoe: 600 mm</b> <b>Counterweight: 6200 kg</b> <b>D/Blade Down</b>	9 m	-	-	*7890	*7890	-	-	-	-	-	-	*5990	*5990	4.41
	7.5 m	-	-	-	-	*7010	*7010	*5930	5930	-	-	*4920	*4920	6.28
	6 m	-	-	*6060	*6060	*7010	*7010	*7170	5950	-	-	*4550	4160	7.40
	4.5 m	-	-	*9910	*9910	*9130	9070	*8480	5760	*6780	4040	*4440	3550	8.09
	3 m	-	-	-	-	*12360	8430	*9360	5490	*7660	3920	*4520	3240	8.45
	1.5 m	-	-	-	-	*13270	7860	*9770	5220	*7710	3790	*4760	3130	8.54
	0 m	-	-	-	-	*12890	7570	*9610	5040	*7400	3700	*5240	3190	8.36
	-1.5 m	-	-	*9410	*9410	*11330	7500	*8660	4970	*6370	3680	*5610	3450	7.89
	-3 m	-	-	-	-	*8660	7600	*6620	5020	-	-	*4660	4060	7.07

: Along undercarriage, : Across undercarriage, H : Lifting hook related to ground level

1. Machine in "Fine Mode-F" (Power Boost), for lifting capacities.
2. The above loads are in compliance with SAE and ISO Hydraulic Excavator Lift Capacity Standards.
3. Rated loads do not exceed 87% of hydraulic lifting capacity or 75% of tipping load.
4. Rated loads marked with an asterisk ( \* ) are limited by hydraulic capacity rather than tipping load.



## Specifications 382 Lifting capacities

	H	1.5 m		3.0 m		4.5 m		6.0 m		7.5 m		Max. Reach		
														Max.
		kg	kg	kg	kg	kg	kg	kg	kg	kg	kg	kg	kg	m
<b>Boom: 5.7 m Dipper arm: 2.5 m Shoe: 700 mm Counterweight: 6200 kg Without D/Blade</b>	9 m	-	-	*8380	*8380	-	-	-	-	-	-	*8380	*8380	3.12
	7.5 m	-	-	-	-	*6890	*6890	-	-	-	-	*6680	6350	5.46
	6 m	-	-	-	-	*7210	*7210	*6880	5460	-	-	*6230	4510	6.72
	4.5 m	-	-	*11790	*11790	*8700	8280	*7430	5310	-	-	5920	3730	7.47
	3 m	-	-	-	-	*10880	7690	8190	5060	5790	3630	5370	3360	7.87
	1.5 m	-	-	-	-	12520	7190	7920	4820	5670	3520	5180	3220	7.96
	0 m	-	-	-	-	12230	6950	7740	4660	5580	3440	5310	3270	7.77
	-1.5 m	-	-	*11650	*11650	12170	6900	7670	4600	-	-	5820	3570	7.26
	-3 m	-	-	*15910	13610	*11700	6980	7740	4660	-	-	7110	4320	6.36
-4.5 m	-	-	*11740	*11740	*8570	7250	-	-	-	-	*7760	6510	4.85	
<b>Boom: 5.7 m Dipper arm: 2.9 m Shoe: 700 mm Counterweight: 6200 kg Without D/Blade</b>	9 m	-	-	-	-	-	-	-	-	-	-	*5830	*5830	4.03
	7.5 m	-	-	-	-	*6150	*6150	*4920	*4920	-	-	*4830	*4830	6.02
	6 m	-	-	-	-	*6530	*6530	*6380	5520	-	-	*4530	4080	7.18
	4.5 m	-	-	*10230	*10230	*8010	*8010	*7000	5360	5930	3750	*4490	3440	7.88
	3 m	-	-	-	-	*10230	7810	*8000	5100	5810	3640	*4650	3120	8.26
	1.5 m	-	-	-	-	*12250	7260	7950	4840	5670	3510	4820	2990	8.35
	0 m	-	-	*6180	*6180	12240	6950	7730	4650	5560	3410	4920	3030	8.17
	-1.5 m	*6750	*6750	*10980	*10980	12120	6850	7630	4560	5520	3380	5340	3270	7.68
	-3 m	*11760	*11760	*17000	13440	*12150	6900	7660	4580	-	-	6330	3860	6.84
-4.5 m	-	-	*13310	*13310	*9670	7100	-	-	-	-	*7590	5390	5.47	
<b>Boom: 5.7 m Dipper arm: 2.5 m Shoe: 700 mm Counterweight: 6200 kg D/Blade Down</b>	9 m	-	-	*8380	*8380	-	-	-	-	-	-	*8380	*8380	3.12
	7.5 m	-	-	-	-	*6890	*6890	-	-	-	-	*6680	*6680	5.46
	6 m	-	-	-	-	*7210	*7210	*6880	6150	-	-	*6230	5090	6.72
	4.5 m	-	-	*11790	*11790	*8700	*8700	*7430	5990	-	-	*6200	4240	7.47
	3 m	-	-	-	-	*10880	8770	*8380	5750	*7220	4130	*6460	3830	7.87
	1.5 m	-	-	-	-	*12700	8260	*9290	5500	*7610	4020	*7010	3680	7.96
	0 m	-	-	-	-	*13390	8010	*9820	5340	*7790	3930	*7490	3750	7.77
	-1.5 m	-	-	*11650	*11650	*13040	7950	*9720	5270	-	-	*7740	4090	7.26
	-3 m	-	-	*15910	*15910	*11700	8040	*8660	5330	-	-	*7950	4940	6.36
-4.5 m	-	-	*11740	*11740	*8570	8310	-	-	-	-	*7760	7450	4.85	
<b>Boom: 5.7 m Dipper arm: 2.9 m Shoe: 700 mm Counterweight: 6200 kg D/Blade Down</b>	9 m	-	-	-	-	-	-	-	-	-	-	*5830	*5830	4.03
	7.5 m	-	-	-	-	*6150	*6150	*4920	*4920	-	-	*4830	*4830	6.02
	6 m	-	-	-	-	*6530	*6530	*6380	6220	-	-	*4530	*4530	7.18
	4.5 m	-	-	*10230	*10230	*8010	*8010	*7000	6050	*6170	4250	*4490	3910	7.88
	3 m	-	-	-	-	*10230	8890	*8000	5790	*6940	4140	*4650	3560	8.26
	1.5 m	-	-	-	-	*12250	8330	*9020	5520	*7410	4010	*4990	3420	8.35
	0 m	-	-	*6180	*6180	*13250	8010	*9680	5330	*7720	3910	*5610	3470	8.17
	-1.5 m	*6750	*6750	*10980	*10980	*13190	7910	*9770	5240	*7580	3870	*6740	3750	7.68
	-3 m	*11760	*11760	*17000	15750	*12150	7950	*9040	5260	-	-	*7560	4420	6.84
-4.5 m	-	-	*13310	*13310	*9670	8160	-	-	-	-	*7590	6170	5.47	

: Along undercarriage, : Across undercarriage, H : Lifting hook related to ground level

1. Machine in "Fine Mode-F" (Power Boost), for lifting capacities.
2. The above loads are in compliance with SAE and ISO Hydraulic Excavator Lift Capacity Standards.
3. Rated loads do not exceed 87% of hydraulic lifting capacity or 75% of tipping load.
4. Rated loads marked with an asterisk ( \* ) are limited by hydraulic capacity rather than tipping load.





**Specifications**  
**Lifting capacities**      **383**

	H	1.5 m		3.0 m		4.5 m		6.0 m		7.5 m		Max. Reach		
														Max.
		kg	kg	kg	kg	kg	kg	kg	kg	kg	kg	kg	kg	m
<b>Boom: 5.76 m</b> <b>Dipper arm: 2.5 m</b> <b>Shoe: 700 mm</b> <b>Counterweight: 6200 kg</b> <b>Without D/Blade</b>	9 m	-	-	*9840	*9840	-	-	-	-	-	-	*8670	*8670	3.57
	7.5 m	-	-	*8290	*8290	*8730	*8730	-	-	-	-	*6830	5790	5.73
	6 m	-	-	*7680	*7680	*8800	8620	8620	5390	-	-	*6280	4200	6.93
	4.5 m	-	-	-	-	*11340	8170	8430	5220	5860	3650	5640	3510	7.67
	3 m	-	-	-	-	*12760	7540	8140	4960	5760	3560	5140	3170	8.05
	1.5 m	-	-	-	-	12430	7040	7870	4720	5640	3450	4990	3060	8.14
	0 m	-	-	-	-	12170	6830	7700	4570	5560	3380	5120	3120	7.95
	-1.5 m	-	-	*9780	*9780	*10700	6820	7660	4540	-	-	5620	3420	7.46
-3 m	-	-	-	-	*7710	6950	*5820	4630	-	-	-	-	6.59	
<b>Boom: 5.76 m</b> <b>Dipper arm: 2.9 m</b> <b>Shoe: 700 mm</b> <b>Counterweight: 6200 kg</b> <b>Without D/Blade</b>	9 m	-	-	*7890	*7890	-	-	-	-	-	-	*5990	*5990	4.41
	7.5 m	-	-	-	-	*7010	*7010	*5930	5460	-	-	*4920	*4920	6.28
	6 m	-	-	*6060	*6060	*7010	*7010	*7170	5460	-	-	*4550	3800	7.40
	4.5 m	-	-	*9910	*9910	*9130	8300	*8480	5280	5900	3680	*4440	3230	8.09
	3 m	-	-	-	-	*12360	7670	8190	5000	5770	3570	*4520	2940	8.45
	1.5 m	-	-	-	-	12520	7110	7890	4740	5640	3440	4640	2830	8.54
	0 m	-	-	-	-	12170	6820	7690	4560	5530	3350	4740	2890	8.36
	-1.5 m	-	-	*9410	*9410	*11330	6760	7610	4490	5510	3330	5150	3120	7.89
-3 m	-	-	-	-	*8660	6860	*6620	4550	-	-	*4660	3680	7.07	
<b>Boom: 5.76 m</b> <b>Dipper arm: 2.5 m</b> <b>Shoe: 700 mm</b> <b>Counterweight: 6200 kg</b> <b>D/Blade Down</b>	9 m	-	-	*9840	*9840	-	-	-	-	-	-	*8670	*8670	3.57
	7.5 m	-	-	*8290	*8290	*8730	*8730	-	-	-	-	*6830	6530	5.73
	6 m	-	-	*7680	*7680	*8800	*8800	*8660	6090	-	-	*6280	4760	6.93
	4.5 m	-	-	-	-	*11340	9260	*9040	5910	*7290	4150	*6140	4000	7.67
	3 m	-	-	-	-	*12760	8620	*9570	5650	*7760	4060	*6280	3630	8.05
	1.5 m	-	-	-	-	*13350	8110	*9840	5410	*7710	3950	*6680	3510	8.14
	0 m	-	-	-	-	*12570	7890	*9490	5260	*7210	3880	*6450	3590	7.95
	-1.5 m	-	-	*9780	*9780	*10700	7880	*8290	5220	-	-	*5810	3920	7.46
-3 m	-	-	-	-	*7710	*7710	*5820	5310	-	-	-	-	6.59	
<b>Boom: 5.76 m</b> <b>Dipper arm: 2.9 m</b> <b>Shoe: 700 mm</b> <b>Counterweight: 6200 kg</b> <b>D/Blade Down</b>	9 m	-	-	*7890	*7890	-	-	-	-	-	-	*5990	*5990	4.41
	7.5 m	-	-	-	-	*7010	*7010	*5930	*5930	-	-	*4920	*4920	6.28
	6 m	-	-	*6060	*6060	*7010	*7010	*7170	6160	-	-	*4550	4320	7.40
	4.5 m	-	-	*9910	*9910	*9130	*9130	*8480	5970	*6780	4190	*4440	3680	8.09
	3 m	-	-	-	-	*12360	8750	*9360	5700	*7660	4070	*4520	3370	8.45
	1.5 m	-	-	-	-	*13270	8180	*9770	5430	*7710	3950	*4760	3260	8.54
	0 m	-	-	-	-	*12890	7890	*9610	5240	*7400	3850	*5240	3320	8.36
	-1.5 m	-	-	*9410	*9410	*11330	7820	*8660	5180	*6370	3830	*5610	3590	7.89
-3 m	-	-	-	-	*8660	7920	*6620	5230	-	-	*4660	4230	7.07	

: Along undercarriage, : Across undercarriage, H : Lifting hook related to ground level

1. Machine in "Fine Mode-F" (Power Boost), for lifting capacities.
2. The above loads are in compliance with SAE and ISO Hydraulic Excavator Lift Capacity Standards.
3. Rated loads do not exceed 87% of hydraulic lifting capacity or 75% of tipping load.
4. Rated loads marked with an asterisk ( \* ) are limited by hydraulic capacity rather than tipping load.



# 384 Specifications Lifting capacities

	H	1.5 m		3.0 m		4.5 m		6.0 m		7.5 m		Max. Reach		
														Max.
		kg	kg	kg	kg	kg	kg	kg	kg	kg	kg	kg	kg	m
<b>Boom: 5.7 m Dipper arm: 2.5 m Shoe: 800 mm Counterweight: 6200 kg Without D/Blade</b>	9 m	-	-	*8380	*8380	-	-	-	-	-	-	*8380	*8380	3.12
	7.5 m	-	-	-	-	*6890	*6890	-	-	-	-	*6680	6410	5.46
	6 m	-	-	-	-	*7210	*7210	*6880	5520	-	-	*6230	4560	6.72
	4.5 m	-	-	*11790	*11790	*8700	8360	*7430	5360	-	-	5990	3780	7.47
	3 m	-	-	-	-	*10880	7780	8290	5120	5860	3670	5430	3400	7.87
	1.5 m	-	-	-	-	12670	7280	8020	4880	5740	3560	5250	3260	7.96
	0 m	-	-	-	-	12380	7030	7830	4710	5650	3480	5370	3310	7.77
	-1.5 m	-	-	*11650	*11650	12310	6980	7760	4650	-	-	5900	3610	7.26
	-3 m	-	-	*15910	13760	*11700	7060	7830	4710	-	-	7190	4370	6.36
-4.5 m	-	-	*11740	*11740	*8570	7330	-	-	-	-	*7760	6580	4.85	
<b>Boom: 5.7 m Dipper arm: 2.9 m Shoe: 800 mm Counterweight: 6200 kg Without D/Blade</b>	9 m	-	-	-	-	-	-	-	-	-	-	*5830	*5830	4.03
	7.5 m	-	-	-	-	*6150	*6150	*4920	*4920	-	-	*4830	*4830	6.02
	6 m	-	-	-	-	*6530	*6530	*6380	5580	-	-	*4530	4130	7.18
	4.5 m	-	-	*10230	*10230	*8010	*8010	*7000	5410	6000	3790	*4490	3480	7.88
	3 m	-	-	-	-	*10230	7900	*8000	5160	5880	3680	*4650	3150	8.26
	1.5 m	-	-	-	-	*12250	7350	8040	4900	5740	3560	4880	3030	8.35
	0 m	-	-	*6180	*6180	12390	7040	7830	4710	5630	3460	4980	3070	8.17
	-1.5 m	*6750	*6750	*10980	*10980	12270	6940	7730	4620	5590	3420	5400	3310	7.68
	-3 m	*11760	*11760	*17000	13600	*12150	6980	7750	4640	-	-	6410	3900	6.84
-4.5 m	-	-	*13310	*13310	*9670	7190	-	-	-	-	*7590	5460	5.47	
<b>Boom: 5.7 m Dipper arm: 2.5 m Shoe: 800 mm Counterweight: 6200 kg D/Blade Down</b>	9 m	-	-	*8380	*8380	-	-	-	-	-	-	*8380	*8380	3.12
	7.5 m	-	-	-	-	*6890	*6890	-	-	-	-	*6680	*6680	5.46
	6 m	-	-	-	-	*7210	*7210	*6880	6320	-	-	*6230	5240	6.72
	4.5 m	-	-	*11790	*11790	*8700	*8700	*7430	6160	-	-	*6200	4360	7.47
	3 m	-	-	-	-	*10880	9030	*8380	5910	*7220	4250	*6460	3940	7.87
	1.5 m	-	-	-	-	*12700	8520	*9290	5670	*7610	4140	*7010	3790	7.96
	0 m	-	-	-	-	*13390	8270	*9820	5500	*7790	4060	*7490	3860	7.77
	-1.5 m	-	-	*11650	*11650	*13040	8210	*9720	5440	-	-	*7740	4220	7.26
	-3 m	-	-	*15910	*15910	*11700	8300	*8660	5500	-	-	*7950	5090	6.36
-4.5 m	-	-	*11740	*11740	*8570	8570	-	-	-	-	*7760	7680	4.85	
<b>Boom: 5.7 m Dipper arm: 2.9 m Shoe: 800 mm Counterweight: 6200 kg D/Blade Down</b>	9 m	-	-	-	-	-	-	-	-	-	-	*5830	*5830	4.03
	7.5 m	-	-	-	-	*6150	*6150	*4920	*4920	-	-	*4830	*4830	6.02
	6 m	-	-	-	-	*6530	*6530	*6380	*6380	-	-	*4530	*4530	7.18
	4.5 m	-	-	*10230	*10230	*8010	*8010	*7000	6220	*6170	4370	*4490	4020	7.88
	3 m	-	-	-	-	*10230	9160	*8000	5950	*6940	4260	*4650	3660	8.26
	1.5 m	-	-	-	-	*12250	8590	*9020	5690	*7410	4130	*4990	3530	8.35
	0 m	-	-	*6180	*6180	*13250	8270	*9680	5490	*7720	4030	*5610	3580	8.17
	-1.5 m	*6750	*6750	*10980	*10980	*13190	8170	*9770	5400	*7580	3990	*6740	3870	7.68
	-3 m	*11760	*11760	*17000	16340	*12150	8220	*9040	5430	-	-	*7560	4560	6.84
-4.5 m	-	-	*13310	*13310	*9670	8430	-	-	-	-	*7590	6360	5.47	

: Along undercarriage, : Across undercarriage, H : Lifting hook related to ground level

1. Machine in "Fine Mode-F" (Power Boost), for lifting capacities.
2. The above loads are in compliance with SAE and ISO Hydraulic Excavator Lift Capacity Standards.
3. Rated loads do not exceed 87% of hydraulic lifting capacity or 75% of tipping load.
4. Rated loads marked with an asterisk ( \* ) are limited by hydraulic capacity rather than tipping load.



**Specifications**  
**Lifting capacities 385**

	H	1.5 m		3.0 m		4.5 m		6.0 m		7.5 m		Max. Reach		
														Max.
		kg	kg	kg	kg	kg	kg	kg	kg	kg	kg	kg	kg	m
<b>Boom: 5.76 m Dipper arm: 2.5 m Shoe: 800 mm Counterweight: 6200 kg Without D/Blade</b>	9 m	-	-	*9840	*9840	-	-	-	-	-	-	*8670	*8670	3.57
	7.5 m	-	-	*8290	*8290	*8730	*8730	-	-	-	-	*6830	5840	5.73
	6 m	-	-	*7680	*7680	*8800	8700	*8660	5450	-	-	*6280	4250	6.93
	4.5 m	-	-	-	-	*11340	8250	8520	5280	5930	3690	5710	3550	7.67
	3 m	-	-	-	-	*12760	7620	8230	5020	5830	3600	5210	3210	8.05
	1.5 m	-	-	-	-	12580	7120	7960	4780	5710	3490	5050	3100	8.14
	0 m	-	-	-	-	12320	6910	7790	4630	5630	3420	5180	3160	7.95
	-1.5 m	-	-	*9780	*9780	*10700	6900	7750	4590	-	-	5690	3460	7.46
	-3 m	-	-	-	-	*7710	7030	*5820	4690	-	-	-	-	6.59
<b>Boom: 5.76 m Dipper arm: 2.9 m Shoe: 800 mm Counterweight: 6200 kg Without D/Blade</b>	9 m	-	-	*7890	*7890	-	-	-	-	-	-	*5990	*5990	4.41
	7.5 m	-	-	-	-	*7010	*7010	*5930	5520	-	-	*4920	*4920	6.28
	6 m	-	-	*6060	*6060	*7010	*7010	*7170	5520	-	-	*4550	3840	7.40
	4.5 m	-	-	*9910	*9910	*9130	8390	*8480	5330	5970	3730	*4440	3270	8.09
	3 m	-	-	-	-	*12360	7750	8290	5060	5840	3610	*4520	2980	8.45
	1.5 m	-	-	-	-	12670	7190	7990	4800	5700	3490	4690	2870	8.54
	0 m	-	-	-	-	12320	6910	7780	4620	5600	3390	4800	2920	8.36
	-1.5 m	-	-	*9410	*9410	*11330	6840	7710	4550	5580	3370	5210	3160	7.89
	-3 m	-	-	-	-	*8660	6940	*6620	4600	-	-	*4660	3730	7.07
<b>Boom: 5.76 m Dipper arm: 2.5 m Shoe: 800 mm Counterweight: 6200 kg D/Blade Down</b>	9 m	-	-	*9840	*9840	-	-	-	-	-	-	*8670	*8670	3.57
	7.5 m	-	-	*8290	*8290	*8730	*8730	-	-	-	-	*6830	6710	5.73
	6 m	-	-	*7680	*7680	*8800	*8800	*8660	6260	-	-	*6280	4900	6.93
	4.5 m	-	-	-	-	*11340	9530	*9040	6080	*7290	4280	*6140	4120	7.67
	3 m	-	-	-	-	*12760	8890	*9570	5820	*7760	4180	*6280	3740	8.05
	1.5 m	-	-	-	-	*13350	8370	*9840	5580	*7710	4070	*6680	3620	8.14
	0 m	-	-	-	-	*12570	8160	*9490	5420	*7210	4000	*6450	3700	7.95
	-1.5 m	-	-	*9780	*9780	*10700	8150	*8290	5390	-	-	*5810	4040	7.46
	-3 m	-	-	-	-	*7710	*7710	*5820	5480	-	-	-	-	6.59
<b>Boom: 5.76 m Dipper arm: 2.9 m Shoe: 800 mm Counterweight: 6200 kg D/Blade Down</b>	9 m	-	-	*7890	*7890	-	-	-	-	-	-	*5990	*5990	4.41
	7.5 m	-	-	-	-	*7010	*7010	*5930	*5930	-	-	*4920	*4920	6.28
	6 m	-	-	*6060	*6060	*7010	*7010	*7170	6330	-	-	*4550	4440	7.40
	4.5 m	-	-	*9910	*9910	*9130	*9130	*8480	6140	*6780	4310	*4440	3800	8.09
	3 m	-	-	-	-	*12360	9020	*9360	5870	*7660	4200	*4520	3480	8.45
	1.5 m	-	-	-	-	*13270	8450	*9770	5600	*7710	4070	*4760	3360	8.54
	0 m	-	-	-	-	*12890	8150	*9610	5410	*7400	3980	*5240	3430	8.36
	-1.5 m	-	-	*9410	*9410	*11330	8090	*8660	5340	*6370	3960	*5610	3710	7.89
	-3 m	-	-	-	-	*8660	8180	*6620	5400	-	-	*4660	4360	7.07

: Along undercarriage, : Across undercarriage, H : Lifting hook related to ground level

1. Machine in "Fine Mode-F" (Power Boost), for lifting capacities.
2. The above loads are in compliance with SAE and ISO Hydraulic Excavator Lift Capacity Standards.
3. Rated loads do not exceed 87% of hydraulic lifting capacity or 75% of tipping load.
4. Rated loads marked with an asterisk ( \* ) are limited by hydraulic capacity rather than tipping load.



# Specifications 386 Lifting capacities

For North America

	H	5ft		10ft		15ft		20ft		25ft		Max. Reach			
															Max.
		lb	lb	lb	lb	lb	lb	lb	lb	lb	lb	lb	lb	lb	ft
<b>Boom: 18' 8"</b> <b>Dipper arm: 8' 2"</b> <b>Shoe: 24"</b> <b>Counterweight: 13669 lb</b> <b>Without D/Blade</b>	30 ft	-	-	-	-	-	-	-	-	-	-	-	-	-	
	25 ft	-	-	-	-	*15310	*15310	-	-	-	-	*14870	14320	17.50	
	20 ft	-	-	-	-	*15730	*15730	*15140	11540	-	-	*13780	9920	21.85	
	15 ft	-	-	*25070	*25070	*18800	17560	*16200	11230	-	-	12880	8130	24.44	
	10 ft	-	-	-	-	*23450	16320	17300	10720	12220	7660	11620	7280	25.80	
	5 ft	-	-	-	-	26370	15230	16720	10200	11970	7430	11190	6950	26.14	
	0 ft	-	-	-	-	25720	14680	16320	9850	11790	7260	11460	7070	25.50	
	-5 ft	-	-	*26580	*26580	25570	14560	16170	9720	-	-	12600	7720	23.79	
	-10 ft	-	-	*34520	28600	*25290	14750	16340	9860	-	-	15490	9410	20.75	
-15 ft	-	-	*25040	*25040	*18000	15370	-	-	-	-	*17040	14530	15.61		
<b>Boom: 18' 8"</b> <b>Dipper arm: 9' 6"</b> <b>Shoe: 24"</b> <b>Counterweight: 13669 lb</b> <b>Without D/Blade</b>	30 ft	-	-	-	-	-	-	-	-	-	-	*13290	*13290	12.30	
	25 ft	-	-	-	-	*13650	*13650	-	-	-	-	*10750	*10750	19.36	
	20 ft	-	-	-	-	*14270	*14270	*14020	11680	-	-	*10010	8960	23.36	
	15 ft	-	-	*21800	*21800	*17330	*17330	*15250	11340	*12460	7900	*9900	7480	25.79	
	10 ft	-	-	-	-	*22050	16570	*17370	10800	12260	7690	*10220	6750	27.09	
	5 ft	-	-	-	-	*26460	15380	16770	10240	11970	7420	10410	6460	27.41	
	0 ft	-	-	*14270	*14270	25740	14690	16310	9830	11740	7210	10620	6540	26.80	
	-5 ft	*15120	*15120	*24960	*24960	25470	14460	16090	9640	11660	7140	11540	7070	25.18	
	-10 ft	*26420	*26420	*36850	28250	25600	14570	16160	9690	-	-	13780	8390	22.34	
-15 ft	-	-	*28510	*28510	*20590	15040	-	-	-	-	*16710	11940	17.67		
<b>Boom: 18' 8"</b> <b>Dipper arm: 8' 2"</b> <b>Shoe: 24"</b> <b>Counterweight: 13669 lb</b> <b>D/Blade Down</b>	30 ft	-	-	-	-	-	-	-	-	-	-	-	-	-	
	25 ft	-	-	-	-	*15310	*15310	-	-	-	-	*14870	*14870	17.50	
	20 ft	-	-	-	-	*15730	*15730	*15140	12780	-	-	*13780	11020	21.85	
	15 ft	-	-	*25070	*25070	*18800	*18800	*16200	12480	-	-	*13670	9070	24.44	
	10 ft	-	-	-	-	*23450	18230	*18180	11960	*15770	8570	*14200	8150	25.80	
	5 ft	-	-	-	-	*27450	17130	*20150	11430	*16550	8340	*15420	7810	26.14	
	0 ft	-	-	-	-	*29020	16570	*21300	11080	*16890	8170	*16510	7950	25.50	
	-5 ft	-	-	*26580	*26580	*28290	16450	*21060	10940	-	-	*17090	8690	23.79	
	-10 ft	-	-	*34520	32620	*25290	16630	*18550	11090	-	-	*17530	10570	20.75	
-15 ft	-	-	*25040	*25040	*18000	17260	-	-	-	-	*17040	16310	15.61		
<b>Boom: 18' 8"</b> <b>Dipper arm: 9' 6"</b> <b>Shoe: 24"</b> <b>Counterweight: 13669 lb</b> <b>D/Blade Down</b>	30 ft	-	-	-	-	-	-	-	-	-	-	*13290	*13290	12.30	
	25 ft	-	-	-	-	*13650	*13650	-	-	-	-	*10750	*10750	19.36	
	20 ft	-	-	-	-	*14270	*14270	*14020	12930	-	-	*10010	9960	23.36	
	15 ft	-	-	*21800	*21800	*17330	*17330	*15250	12590	*12460	8820	*9900	8360	25.79	
	10 ft	-	-	-	-	*22050	18490	*17370	12040	*15140	8600	*10220	7570	27.09	
	5 ft	-	-	-	-	*26460	17280	*19550	11470	*16130	8330	*10990	7260	27.41	
	0 ft	-	-	*14270	*14270	*28700	16580	*21000	11060	*16750	8120	*12380	7370	26.80	
	-5 ft	*15120	*15120	*24960	*24960	*28610	16350	*21180	10860	*16330	8050	*14900	7970	25.18	
	-10 ft	*26420	*26420	*36850	32250	*26290	16450	*19470	10920	-	-	*16680	9440	22.34	
-15 ft	-	-	*28510	*28510	*20590	16930	-	-	-	-	*16710	13410	17.67		

: Along undercarriage, : Across undercarriage, H : Lifting hook related to ground level

1. Machine in "Fine Mode-F" (Power Boost), for lifting capacities.
2. The above loads are in compliance with SAE and ISO Hydraulic Excavator Lift Capacity Standards.
3. Rated loads do not exceed 87% of hydraulic lifting capacity or 75% of tipping load.
4. Rated loads marked with an asterisk ( \* ) are limited by hydraulic capacity rather than tipping load.



Specifications  
Lifting capacities **387**

	H	5ft		10ft		15ft		20ft		25ft		Max. Reach		
														Max.
		lb	lb	lb	lb	lb	lb	lb	lb	lb	lb	lb	lb	ft
<b>Boom: 18' 10"</b> <b>Dipper arm: 8' 2"</b> <b>Shoe: 24"</b> <b>Counterweight: 13669 lb</b> <b>Without D/Blade</b>	30 ft	-	-	*21210	*21210	-	-	-	-	-	-	*20010	*20010	10.67
	25 ft	-	-	*18600	*18600	*19240	18490	-	-	-	-	*15220	13000	18.39
	20 ft	-	-	*16960	*16960	*19360	18250	18170	11390	-	-	*13880	9230	22.56
	15 ft	-	-	*34990	34090	*24540	17320	17800	11050	12330	7680	12260	7630	25.07
	10 ft	-	-	-	-	27480	16000	17190	10510	12140	7510	11130	6870	26.40
	5 ft	-	-	-	-	26170	14900	16600	9990	11900	7280	10770	6600	26.74
	0 ft	-	-	-	-	25590	14420	16230	9660	11740	7140	11050	6740	26.11
	-5 ft	-	-	*22430	*22430	*23260	14390	16150	9590	-	-	12150	7390	24.44
	-10 ft	-	-	-	-	*16590	14690	*12220	9810	-	-	-	-	21.50
<b>Boom: 18' 10"</b> <b>Dipper arm: 9' 6"</b> <b>Shoe: 24"</b> <b>Counterweight: 13669 lb</b> <b>Without D/Blade</b>	30 ft	-	-	*17480	*17480	-	-	-	-	-	-	*13660	*13660	13.66
	25 ft	-	-	-	-	*15500	*15500	*11710	11460	-	-	*10960	*10960	20.24
	20 ft	-	-	*13420	*13420	*15460	*15460	*15600	11540	-	-	*10060	8330	24.09
	15 ft	-	-	*20360	*20360	*19600	17610	17940	11170	12430	7760	*9800	7020	26.46
	10 ft	-	-	-	-	*26720	16260	17290	10590	12180	7530	*9950	6360	27.72
	5 ft	-	-	-	-	26360	15050	16650	10020	11890	7270	10010	6120	28.04
	0 ft	-	-	-	-	25590	14410	16210	9630	11680	7080	10240	6230	27.44
	-5 ft	-	-	*21470	*21470	*24610	14270	16050	9490	11650	7050	11130	6760	25.86
	-10 ft	-	-	-	-	*18670	14470	*14080	9620	-	-	*10180	8010	23.10
<b>Boom: 18' 10"</b> <b>Dipper arm: 8' 2"</b> <b>Shoe: 24"</b> <b>Counterweight: 13669 lb</b> <b>D/Blade Down</b>	30 ft	-	-	*21210	*21210	-	-	-	-	-	-	*20010	*20010	10.67
	25 ft	-	-	*18600	*18600	*19240	*19240	-	-	-	-	*15220	14420	18.39
	20 ft	-	-	*16960	*16960	*19360	*19360	*18910	12640	-	-	*13880	10290	22.56
	15 ft	-	-	-	-	*24540	19270	*19650	12300	*13970	8600	*13550	8550	25.07
	10 ft	-	-	-	-	*27590	17920	*20770	11750	*16850	8420	*13830	7730	26.40
	5 ft	-	-	-	-	*28950	16810	*21340	11230	*16680	8200	*14690	7440	26.74
	0 ft	-	-	-	-	*27350	16320	*20580	10900	*15500	8050	*14220	7610	26.11
	-5 ft	-	-	*22430	*22430	*23260	16290	*17900	10820	-	-	*12780	8330	24.44
	-10 ft	-	-	-	-	*16590	*16590	*12220	11050	-	-	-	-	21.50
<b>Boom: 18' 10"</b> <b>Dipper arm: 9' 6"</b> <b>Shoe: 24"</b> <b>Counterweight: 13669 lb</b> <b>D/Blade Down</b>	30 ft	-	-	*17480	*17480	-	-	-	-	-	-	*13660	*13660	13.66
	25 ft	-	-	-	-	*15500	*15500	*11710	*11710	-	-	*10960	*10960	20.24
	20 ft	-	-	*13420	*13420	*15460	*15460	*15600	12800	-	-	*10060	9300	24.09
	15 ft	-	-	*20360	*20360	*19600	19560	*18370	12420	*14110	8680	*9800	7870	26.46
	10 ft	-	-	-	-	*26720	18190	*20310	11840	*16630	8450	*9950	7160	27.72
	5 ft	-	-	-	-	*28760	16960	*21180	11270	*16710	8180	*10490	6910	28.04
	0 ft	-	-	-	-	*28000	16310	*20840	10870	*15970	7990	*11530	7040	27.44
	-5 ft	-	-	*21470	*21470	*24610	16160	*18720	10720	*13530	7960	*12350	7630	25.86
	-10 ft	-	-	-	-	*18670	16370	*14080	10860	-	-	*10180	9020	23.10

: Along undercarriage, : Across undercarriage, H : Lifting hook related to ground level

1. Machine in "Fine Mode-F" (Power Boost), for lifting capacities.
2. The above loads are in compliance with SAE and ISO Hydraulic Excavator Lift Capacity Standards.
3. Rated loads do not exceed 87% of hydraulic lifting capacity or 75% of tipping load.
4. Rated loads marked with an asterisk ( \* ) are limited by hydraulic capacity rather than tipping load.



# 388 Specifications Lifting capacities

	H	5ft		10ft		15ft		20ft		25ft		Max. Reach		
														Max.
		lb	lb	lb	lb	lb	lb	lb	lb	lb	lb	lb	lb	ft
<b>Boom: 18' 8"</b> <b>Dipper arm: 8' 2"</b> <b>Shoe: 28"</b> <b>Counterweight: 13669 lb</b> <b>Without D/Blade</b>	30 ft	-	-	-	-	-	-	-	-	-	-	-	-	-
	25 ft	-	-	-	-	*15310	*15310	-	-	-	-	*14870	14560	17.50
	20 ft	-	-	-	-	*15730	*15730	*15140	11740	-	-	*13780	10110	21.85
	15 ft	-	-	*25070	*25070	*18800	17860	*16200	11440	-	-	13140	8290	24.44
	10 ft	-	-	-	-	*23450	16620	17640	10920	12470	7810	11860	7430	25.80
	5 ft	-	-	-	-	26910	15530	17060	10410	12220	7580	11430	7100	26.14
	0 ft	-	-	-	-	26250	14980	16660	10050	12040	7420	11700	7220	25.50
	-5 ft	-	-	*26580	*26580	26100	14860	16520	9920	-	-	12870	7890	23.79
	-10 ft	-	-	*34520	29160	*25290	15050	16680	10070	-	-	15820	9600	20.75
-15 ft	-	-	*25040	*25040	*18000	15670	-	-	-	-	*17040	14810	15.61	
<b>Boom: 18' 8"</b> <b>Dipper arm: 9' 6"</b> <b>Shoe: 28"</b> <b>Counterweight: 13669 lb</b> <b>Without D/Blade</b>	30 ft	-	-	-	-	-	-	-	-	-	-	*13290	*13290	12.30
	25 ft	-	-	-	-	*13650	*13650	-	-	-	-	*10750	*10750	19.36
	20 ft	-	-	-	-	*14270	*14270	*14020	11890	-	-	*10010	9130	23.36
	15 ft	-	-	*21800	*21800	*17330	*17330	*15250	11550	*12460	8060	*9900	7630	25.79
	10 ft	-	-	-	-	*22050	16870	*17370	11010	12510	7840	*10220	6890	27.09
	5 ft	-	-	-	-	*26460	15680	17120	10450	12220	7580	10630	6600	27.41
	0 ft	-	-	*14270	*14270	26280	14990	16650	10030	11990	7370	10850	6680	26.80
	-5 ft	*15120	*15120	*24960	*24960	26010	14760	16440	9840	11910	7300	11790	7230	25.18
	-10 ft	*26420	*26420	*36850	28810	26130	14870	16500	9900	-	-	14080	8570	22.34
-15 ft	-	-	*28510	*28510	*20590	15340	-	-	-	-	*16710	12180	17.67	
<b>Boom: 18' 8"</b> <b>Dipper arm: 8' 2"</b> <b>Shoe: 28"</b> <b>Counterweight: 13669 lb</b> <b>D/Blade Down</b>	30 ft	-	-	-	-	-	-	-	-	-	-	-	-	-
	25 ft	-	-	-	-	*15310	*15310	-	-	-	-	*14870	*14870	17.50
	20 ft	-	-	-	-	*15730	*15730	*15140	13230	-	-	*13780	11410	21.85
	15 ft	-	-	*25070	*25070	*18800	*18800	*16200	12920	-	-	*13670	9410	24.44
	10 ft	-	-	-	-	*23450	18920	*18180	12400	*15770	8890	*14200	8460	25.80
	5 ft	-	-	-	-	*27450	17810	*20150	11880	*16550	8660	*15420	8120	26.14
	0 ft	-	-	-	-	*29020	17250	*21300	11520	*16890	8490	*16510	8270	25.50
	-5 ft	-	-	*26580	*26580	*28290	17130	*21060	11380	-	-	*17090	9040	23.79
	-10 ft	-	-	*34520	34090	*25290	17320	*18550	11530	-	-	*17530	10990	20.75
-15 ft	-	-	*25040	*25040	*18000	17950	-	-	-	-	*17040	16950	15.61	
<b>Boom: 18' 8"</b> <b>Dipper arm: 9' 6"</b> <b>Shoe: 28"</b> <b>Counterweight: 13669 lb</b> <b>D/Blade Down</b>	30 ft	-	-	-	-	-	-	-	-	-	-	*13290	*13290	12.30
	25 ft	-	-	-	-	*13650	*13650	-	-	-	-	*10750	*10750	19.36
	20 ft	-	-	-	-	*14270	*14270	*14020	13380	-	-	*10010	*10010	23.36
	15 ft	-	-	*21800	*21800	*17330	*17330	*15250	13030	*12460	9140	*9900	8670	25.79
	10 ft	-	-	-	-	*22050	19180	*17370	12480	*15140	8920	*10220	7860	27.09
	5 ft	-	-	-	-	*26460	17970	*19550	11920	*16130	8650	*10990	7550	27.41
	0 ft	-	-	*14270	*14270	*28700	17260	*21000	11500	*16750	8440	*12380	7660	26.80
	-5 ft	*15120	*15120	*24960	*24960	*28610	17030	*21180	11300	*16330	8370	*14900	8290	25.18
	-10 ft	*26420	*26420	*36850	33720	*26290	17140	*19470	11360	-	-	*16680	9820	22.34
-15 ft	-	-	*28510	*28510	*20590	17620	-	-	-	-	*16710	13940	17.67	

: Along undercarriage, : Across undercarriage, H : Lifting hook related to ground level

1. Machine in "Fine Mode-F" (Power Boost), for lifting capacities.
2. The above loads are in compliance with SAE and ISO Hydraulic Excavator Lift Capacity Standards.
3. Rated loads do not exceed 87% of hydraulic lifting capacity or 75% of tipping load.
4. Rated loads marked with an asterisk ( \* ) are limited by hydraulic capacity rather than tipping load.



Specifications  
Lifting capacities **389**

	H	5ft		10ft		15ft		20ft		25ft		Max. Reach		
														Max.
		lb	lb	lb	lb	lb	lb	lb	lb	lb	lb	lb	lb	ft
<b>Boom: 18' 10"</b> <b>Dipper arm: 8' 2"</b> <b>Shoe: 28"</b> <b>Counterweight: 13669 lb</b> <b>Without D/Blade</b>	30 ft	-	-	*21210	*21210	-	-	-	-	-	-	*20010	*20010	10.67
	25 ft	-	-	*18600	*18600	*19240	18790	-	-	-	-	*15220	13230	18.39
	20 ft	-	-	*16960	*16960	*19360	18550	18520	11590	-	-	*13880	9410	22.56
	15 ft	-	-	-	-	*24540	17620	18140	11260	12580	7830	12520	7790	25.07
	10 ft	-	-	-	-	*27590	16300	17530	10710	12390	7660	11370	7020	26.40
	5 ft	-	-	-	-	26700	15200	16940	10200	12150	7440	11000	6750	26.74
	0 ft	-	-	-	-	26120	14720	16570	9870	11990	7300	11290	6890	26.11
	-5 ft	-	-	*22430	*22430	*23260	14690	16490	9790	-	-	12410	7550	24.44
	-10 ft	-	-	-	-	*16590	14990	*12220	10020	-	-	-	-	21.50
<b>Boom: 18' 10"</b> <b>Dipper arm: 9' 6"</b> <b>Shoe: 28"</b> <b>Counterweight: 13669 lb</b> <b>Without D/Blade</b>	30 ft	-	-	*17480	*17480	-	-	-	-	-	-	*13660	*13660	13.66
	25 ft	-	-	-	-	*15500	*15500	*11710	11670	-	-	*10960	*10960	20.24
	20 ft	-	-	*13420	*13420	*15460	*15460	*15600	11740	-	-	*10060	8500	24.09
	15 ft	-	-	*20360	*20360	*19600	17910	18280	11370	12680	7920	*9800	7160	26.46
	10 ft	-	-	-	-	*26720	16560	17640	10800	12430	7690	*9950	6500	27.72
	5 ft	-	-	-	-	26890	15350	16990	10230	12140	7420	10230	6260	28.04
	0 ft	-	-	-	-	26120	14710	16550	9840	11930	7230	10460	6370	27.44
	-5 ft	-	-	*21470	*21470	*24610	14570	16390	9690	11900	7200	11370	6910	25.86
	-10 ft	-	-	-	-	*18670	14770	*14080	9820	-	-	*10180	8180	23.10
<b>Boom: 18' 10"</b> <b>Dipper arm: 8' 2"</b> <b>Shoe: 28"</b> <b>Counterweight: 13669 lb</b> <b>D/Blade Down</b>	30 ft	-	-	*21210	*21210	-	-	-	-	-	-	*20010	*20010	10.67
	25 ft	-	-	*18600	*18600	*19240	*19240	-	-	-	-	*15220	14930	18.39
	20 ft	-	-	*16960	*16960	*19360	*19360	*18910	13090	-	-	*13880	10670	22.56
	15 ft	-	-	-	-	*24540	19970	*19650	12750	*13970	8930	*13550	8880	25.07
	10 ft	-	-	-	-	*27590	18610	*20770	12200	*16850	8750	*13830	8030	26.40
	5 ft	-	-	-	-	*28950	17500	*21340	11670	*16680	8530	*14690	7740	26.74
	0 ft	-	-	-	-	*27350	17000	*20580	11340	*15500	8380	*14220	7910	26.11
	-5 ft	-	-	*22430	*22430	*23260	16970	*17900	11270	-	-	*12780	8670	24.44
	-10 ft	-	-	-	-	*16590	*16590	*12220	11490	-	-	-	-	21.50
<b>Boom: 18' 10"</b> <b>Dipper arm: 9' 6"</b> <b>Shoe: 28"</b> <b>Counterweight: 13669 lb</b> <b>D/Blade Down</b>	30 ft	-	-	*17480	*17480	-	-	-	-	-	-	*13660	*13660	13.66
	25 ft	-	-	-	-	*15500	*15500	*11710	*11710	-	-	*10960	*10960	20.24
	20 ft	-	-	*13420	*13420	*15460	*15460	*15600	13250	-	-	*10060	9650	24.09
	15 ft	-	-	*20360	*20360	*19600	*19600	*18370	12870	*14110	9010	*9800	8170	26.46
	10 ft	-	-	-	-	*26720	18890	*20310	12290	*16630	8780	*9950	7450	27.72
	5 ft	-	-	-	-	*28760	17650	*21180	11710	*16710	8510	*10490	7190	28.04
	0 ft	-	-	-	-	*28000	16990	*20840	11310	*15970	8320	*11530	7330	27.44
	-5 ft	-	-	*21470	*21470	*24610	16850	*18720	11170	*13530	8290	*12350	7950	25.86
	-10 ft	-	-	-	-	*18670	17060	*14080	11300	-	-	*10180	9390	23.10

: Along undercarriage, : Across undercarriage, H : Lifting hook related to ground level

1. Machine in "Fine Mode-F" (Power Boost), for lifting capacities.
2. The above loads are in compliance with SAE and ISO Hydraulic Excavator Lift Capacity Standards.
3. Rated loads do not exceed 87% of hydraulic lifting capacity or 75% of tipping load.
4. Rated loads marked with an asterisk ( \* ) are limited by hydraulic capacity rather than tipping load.



# 390 Specifications Lifting capacities

	H	5ft		10ft		15ft		20ft		25ft		Max. Reach		
														Max.
		lb	lb	lb	lb	lb	lb	lb	lb	lb	lb	lb	lb	ft
<b>Boom: 18' 8"</b> <b>Dipper arm: 8' 2"</b> <b>Shoe: 32"</b> <b>Counterweight: 13669 lb</b> <b>Without D/Blade</b>	30 ft	-	-	-	-	-	-	-	-	-	-	-	-	
	25 ft	-	-	-	-	*15310	*15310	-	-	-	-	*14870	14710	17.50
	20 ft	-	-	-	-	*15730	*15730	*15140	11870	-	-	*13780	10220	21.85
	15 ft	-	-	*25070	*25070	*18800	18040	*16200	11560	-	-	13290	8390	24.44
	10 ft	-	-	-	-	*23450	16800	17850	11050	12620	7900	12000	7520	25.80
	5 ft	-	-	-	-	27220	15710	17270	10530	12370	7680	11570	7190	26.14
	0 ft	-	-	-	-	26560	15160	16870	10180	12190	7510	11850	7310	25.50
	-5 ft	-	-	*26580	*26580	26420	15040	16720	10050	-	-	13030	7990	23.79
	-10 ft	-	-	*34520	29500	*25290	15230	16880	10190	-	-	16010	9720	20.75
	-15 ft	-	-	*25040	*25040	*18000	15840	-	-	-	-	*17040	14980	15.61
<b>Boom: 18' 8"</b> <b>Dipper arm: 9' 6"</b> <b>Shoe: 32"</b> <b>Counterweight: 13669 lb</b> <b>Without D/Blade</b>	30 ft	-	-	-	-	-	-	-	-	-	-	*13290	*13290	12.30
	25 ft	-	-	-	-	*13650	*13650	-	-	-	-	*10750	*10750	19.36
	20 ft	-	-	-	-	*14270	*14270	*14020	12010	-	-	*10010	9230	23.36
	15 ft	-	-	*21800	*21800	*17330	*17330	*15250	11670	*12460	8150	*9900	7720	25.79
	10 ft	-	-	-	-	*22050	17050	*17370	11130	12660	7930	*10220	6970	27.09
	5 ft	-	-	-	-	*26460	15860	17320	10570	12370	7670	10770	6680	27.41
	0 ft	-	-	*14270	*14270	26590	15170	16850	10160	12140	7460	10980	6770	26.80
	-5 ft	*15120	*15120	*24960	*24960	26320	14940	16640	9960	12060	7390	11940	7320	25.18
	-10 ft	*26420	*26420	*36850	29140	*26290	15050	16700	10020	-	-	14250	8680	22.34
	-15 ft	-	-	*28510	*28510	*20590	15520	-	-	-	-	*16710	12320	17.67
<b>Boom: 18' 8"</b> <b>Dipper arm: 8' 2"</b> <b>Shoe: 32"</b> <b>Counterweight: 13669 lb</b> <b>D/Blade Down</b>	30 ft	-	-	-	-	-	-	-	-	-	-	-	-	
	25 ft	-	-	-	-	*15310	*15310	-	-	-	-	*14870	*14870	17.50
	20 ft	-	-	-	-	*15730	*15730	*15140	13600	-	-	*13780	11730	21.85
	15 ft	-	-	*25070	*25070	*18800	*18800	*16200	13290	-	-	*13670	9680	24.44
	10 ft	-	-	-	-	*23450	19490	*18180	12760	*15770	9160	*14200	8710	25.80
	5 ft	-	-	-	-	*27450	18370	*20150	12240	*16550	8920	*15420	8360	26.14
	0 ft	-	-	-	-	*29020	17810	*21300	11870	*16890	8760	*16510	8520	25.50
	-5 ft	-	-	*26580	*26580	*28290	17690	*21060	11740	-	-	*17090	9320	23.79
	-10 ft	-	-	*34520	*34520	*25290	17880	*18550	11890	-	-	*17530	11330	20.75
	-15 ft	-	-	*25040	*25040	*18000	*18000	-	-	-	-	*17040	*17040	15.61
<b>Boom: 18' 8"</b> <b>Dipper arm: 9' 6"</b> <b>Shoe: 32"</b> <b>Counterweight: 13669 lb</b> <b>D/Blade Down</b>	30 ft	-	-	-	-	-	-	-	-	-	-	*13290	*13290	12.30
	25 ft	-	-	-	-	*13650	*13650	-	-	-	-	*10750	*10750	19.36
	20 ft	-	-	-	-	*14270	*14270	*14020	13740	-	-	*10010	*10010	23.36
	15 ft	-	-	*21800	*21800	*17330	*17330	*15250	13400	*12460	9410	*9900	8920	25.79
	10 ft	-	-	-	-	*22050	19750	*17370	12850	*15140	9190	*10220	8100	27.09
	5 ft	-	-	-	-	*26460	18530	*19550	12280	*16130	8920	*10990	7780	27.41
	0 ft	-	-	*14270	*14270	*28700	17820	*21000	11860	*16750	8700	*12380	7900	26.80
	-5 ft	*15120	*15120	*24960	*24960	*28610	17590	*21180	11660	*16330	8630	*14900	8550	25.18
	-10 ft	*26420	*26420	*36850	34970	*26290	17700	*19470	11720	-	-	*16680	10130	22.34
	-15 ft	-	-	*28510	*28510	*20590	18180	-	-	-	-	*16710	14370	17.67

: Along undercarriage, : Across undercarriage, H : Lifting hook related to ground level

1. Machine in "Fine Mode-F" (Power Boost), for lifting capacities.
2. The above loads are in compliance with SAE and ISO Hydraulic Excavator Lift Capacity Standards.
3. Rated loads do not exceed 87% of hydraulic lifting capacity or 75% of tipping load.
4. Rated loads marked with an asterisk ( \* ) are limited by hydraulic capacity rather than tipping load.





Specifications  
Lifting capacities **391**

	H	5ft		10ft		15ft		20ft		25ft		Max. Reach		
														Max.
		lb	lb	lb	lb	lb	lb	lb	lb	lb	lb	lb	lb	ft
<b>Boom: 18' 10"</b> <b>Dipper arm: 8' 2"</b> <b>Shoe: 32"</b> <b>Counterweight: 13669 lb</b> <b>Without D/Blade</b>	30 ft	-	-	*21210	*21210	-	-	-	-	-	-	*20010	*20010	10.67
	25 ft	-	-	*18600	*18600	*19240	18970	-	-	-	-	*15220	13370	18.39
	20 ft	-	-	*16960	*16960	*19360	18730	18720	11710	-	-	*13880	9510	22.56
	15 ft	-	-	-	-	*24540	17800	18340	11380	12730	7930	12660	7880	25.07
	10 ft	-	-	-	-	*27590	16470	17730	10840	12540	7750	11510	7110	26.40
	5 ft	-	-	-	-	27020	15380	17150	10320	12300	7530	11140	6830	26.74
	0 ft	-	-	-	-	26440	14900	16780	9990	12140	7390	11430	6980	26.11
	-5 ft	-	-	*22430	*22430	*23260	14870	16690	9920	-	-	12570	7650	24.44
	-10 ft	-	-	-	-	*16590	15160	*12220	10140	-	-	-	-	21.50
<b>Boom: 18' 10"</b> <b>Dipper arm: 9' 6"</b> <b>Shoe: 32"</b> <b>Counterweight: 13669 lb</b> <b>Without D/Blade</b>	30 ft	-	-	*17480	*17480	-	-	-	-	-	-	*13660	*13660	13.66
	25 ft	-	-	-	-	*15500	*15500	*11710	*11710	-	-	*10960	*10960	20.24
	20 ft	-	-	*13420	*13420	*15460	*15460	*15600	11870	-	-	*10060	8590	24.09
	15 ft	-	-	*20360	*20360	*19600	18090	*18370	11490	12830	8010	*9800	7250	26.46
	10 ft	-	-	-	-	*26720	16740	17840	10920	12580	7780	*9950	6580	27.72
	5 ft	-	-	-	-	27210	15520	17200	10350	12290	7520	10360	6340	28.04
	0 ft	-	-	-	-	26440	14890	16750	9960	12080	7320	10590	6450	27.44
	-5 ft	-	-	*21470	*21470	*24610	14740	16590	9820	12050	7290	11520	7000	25.86
	-10 ft	-	-	-	-	*18670	14950	*14080	9950	-	-	*10180	8280	23.10
<b>Boom: 18' 10"</b> <b>Dipper arm: 8' 2"</b> <b>Shoe: 32"</b> <b>Counterweight: 13669 lb</b> <b>D/Blade Down</b>	30 ft	-	-	*21210	*21210	-	-	-	-	-	-	*20010	*20010	10.67
	25 ft	-	-	*18600	*18600	*19240	*19240	-	-	-	-	*15220	*15220	18.39
	20 ft	-	-	*16960	*16960	*19360	*19360	*18910	13460	-	-	*13880	10970	22.56
	15 ft	-	-	-	-	*24540	20550	*19650	13120	*13970	9190	*13550	9140	25.07
	10 ft	-	-	-	-	*27590	19190	*20770	12570	*16850	9020	*13830	8280	26.40
	5 ft	-	-	-	-	*28950	18060	*21340	12040	*16680	8790	*14690	7980	26.74
	0 ft	-	-	-	-	*27350	17570	*20580	11700	*15500	8650	*14220	8160	26.11
	-5 ft	-	-	*22430	*22430	*23260	17540	*17900	11630	-	-	*12780	8940	24.44
	-10 ft	-	-	-	-	*16590	*16590	*12220	11850	-	-	-	-	21.50
<b>Boom: 18' 10"</b> <b>Dipper arm: 9' 6"</b> <b>Shoe: 32"</b> <b>Counterweight: 13669 lb</b> <b>D/Blade Down</b>	30 ft	-	-	*17480	*17480	-	-	-	-	-	-	*13660	*13660	13.66
	25 ft	-	-	-	-	*15500	*15500	*11710	*11710	-	-	*10960	*10960	20.24
	20 ft	-	-	*13420	*13420	*15460	*15460	*15600	13620	-	-	*10060	9930	24.09
	15 ft	-	-	*20360	*20360	*19600	*19600	*18370	13240	*14110	9280	*9800	8420	26.46
	10 ft	-	-	-	-	*26720	19470	*20310	12650	*16630	9050	*9950	7680	27.72
	5 ft	-	-	-	-	*28760	18220	*21180	12070	*16710	8780	*10490	7420	28.04
	0 ft	-	-	-	-	*28000	17560	*20840	11670	*15970	8580	*11530	7560	27.44
	-5 ft	-	-	*21470	*21470	*24610	17410	*18720	11530	*13530	8550	*12350	8200	25.86
	-10 ft	-	-	-	-	*18670	17630	*14080	11660	-	-	*10180	9680	23.10

: Along undercarriage, : Across undercarriage, H : Lifting hook related to ground level

1. Machine in "Fine Mode-F" (Power Boost), for lifting capacities.
2. The above loads are in compliance with SAE and ISO Hydraulic Excavator Lift Capacity Standards.
3. Rated loads do not exceed 87% of hydraulic lifting capacity or 75% of tipping load.
4. Rated loads marked with an asterisk ( \* ) are limited by hydraulic capacity rather than tipping load.



## 392 Specifications Lifting capacities

	H	5ft		10ft		15ft		20ft		25ft		Max. Reach		
														Max.
		lb	lb	lb	lb	lb	lb	lb	lb	lb	lb	lb	lb	ft
<b>Boom: 18' 8"</b> <b>Dipper arm: 8' 2"</b> <b>Shoe: 35"</b> <b>Counterweight: 13669 lb</b> <b>Without D/Blade</b>	30 ft	-	-	-	-	-	-	-	-	-	-	-	-	
	25 ft	-	-	-	-	*15310	*15310	-	-	-	-	*14870	14860	17.50
	20 ft	-	-	-	-	*15730	*15730	*15140	12000	-	-	*13780	10330	21.85
	15 ft	-	-	*25070	*25070	*18800	18230	*16200	11690	-	-	13460	8490	24.44
	10 ft	-	-	-	-	*23450	16990	18060	11180	12780	8000	12160	7610	25.80
	5 ft	-	-	-	-	*27450	15900	17480	10660	12530	7780	11720	7280	26.14
	0 ft	-	-	-	-	26900	15350	17080	10310	12350	7610	12000	7410	25.50
	-5 ft	-	-	*26580	*26580	26760	15230	16940	10180	-	-	13200	8090	23.79
	-10 ft	-	-	*34520	29850	*25290	15420	17100	10320	-	-	16210	9840	20.75
	-15 ft	-	-	*25040	*25040	*18000	16040	-	-	-	-	*17040	15160	15.61
<b>Boom: 18' 8"</b> <b>Dipper arm: 9' 6"</b> <b>Shoe: 35"</b> <b>Counterweight: 13669 lb</b> <b>Without D/Blade</b>	30 ft	-	-	-	-	-	-	-	-	-	-	*13290	*13290	12.30
	25 ft	-	-	-	-	*13650	*13650	-	-	-	-	*10750	*10750	19.36
	20 ft	-	-	-	-	*14270	*14270	*14020	12140	-	-	*10010	9340	23.36
	15 ft	-	-	*21800	*21800	*17330	*17330	*15250	11800	*12460	8250	*9900	7820	25.79
	10 ft	-	-	-	-	*22050	17240	*17370	11260	12820	8030	*10220	7060	27.09
	5 ft	-	-	-	-	*26460	16050	17540	10700	12530	7770	10910	6770	27.41
	0 ft	-	-	*14270	*14270	26930	15360	17070	10290	12300	7560	11130	6860	26.80
	-5 ft	*15120	*15120	*24960	*24960	26660	15130	16860	10090	12220	7490	12100	7410	25.18
	-10 ft	*26420	*26420	*36850	29490	*26290	15240	16920	10150	-	-	14440	8790	22.34
	-15 ft	-	-	*28510	*28510	*20590	15710	-	-	-	-	*16710	12480	17.67
<b>Boom: 18' 8"</b> <b>Dipper arm: 8' 2"</b> <b>Shoe: 35"</b> <b>Counterweight: 13669 lb</b> <b>D/Blade Down</b>	30 ft	-	-	-	-	-	-	-	-	-	-	-	-	
	25 ft	-	-	-	-	*15310	*15310	-	-	-	-	*14870	*14870	17.50
	20 ft	-	-	-	-	*15730	*15730	*15140	13740	-	-	*13780	11860	21.85
	15 ft	-	-	*25070	*25070	*18800	*18800	*16200	13430	-	-	*13670	9790	24.44
	10 ft	-	-	-	-	*23450	19700	*18180	12900	*15770	9260	*14200	8820	25.80
	5 ft	-	-	-	-	*27450	18580	*20150	12380	*16550	9030	*15420	8460	26.14
	0 ft	-	-	-	-	*29020	18020	*21300	12020	*16890	8860	*16510	8630	25.50
	-5 ft	-	-	*26580	*26580	*28290	17900	*21060	11880	-	-	*17090	9430	23.79
	-10 ft	-	-	*34520	*34520	*25290	18090	*18550	12030	-	-	*17530	11460	20.75
	-15 ft	-	-	*25040	*25040	*18000	*18000	-	-	-	-	*17040	*17040	15.61
<b>Boom: 18' 8"</b> <b>Dipper arm: 9' 6"</b> <b>Shoe: 35"</b> <b>Counterweight: 13669 lb</b> <b>D/Blade Down</b>	30 ft	-	-	-	-	-	-	-	-	-	-	*13290	*13290	12.30
	25 ft	-	-	-	-	*13650	*13650	-	-	-	-	*10750	*10750	19.36
	20 ft	-	-	-	-	*14270	*14270	*14020	13890	-	-	*10010	*10010	23.36
	15 ft	-	-	*21800	*21800	*17330	*17330	*15250	13540	*12460	9520	*9900	9030	25.79
	10 ft	-	-	-	-	*22050	19960	*17370	12990	*15140	9290	*10220	8190	27.09
	5 ft	-	-	-	-	*26460	18740	*19550	12420	*16130	9020	*10990	7880	27.41
	0 ft	-	-	*14270	*14270	*28700	18030	*21000	12000	*16750	8810	*12380	8000	26.80
	-5 ft	*15120	*15120	*24960	*24960	*28610	17800	*21180	11800	*16330	8740	*14900	8660	25.18
	-10 ft	*26420	*26420	*36850	35370	*26290	17910	*19470	11860	-	-	*16680	10250	22.34
	-15 ft	-	-	*28510	*28510	*20590	18390	-	-	-	-	*16710	14540	17.67

: Along undercarriage, : Across undercarriage, H : Lifting hook related to ground level

1. Machine in "Fine Mode-F" (Power Boost), for lifting capacities.
2. The above loads are in compliance with SAE and ISO Hydraulic Excavator Lift Capacity Standards.
3. Rated loads do not exceed 87% of hydraulic lifting capacity or 75% of tipping load.
4. Rated loads marked with an asterisk ( \* ) are limited by hydraulic capacity rather than tipping load.



Specifications  
Lifting capacities **393**

	H	5ft		10ft		15ft		20ft		25ft		Max. Reach		
														Max.
		lb	lb	lb	lb	lb	lb	lb	lb	lb	lb	lb	lb	ft
<b>Boom: 18' 10"</b> <b>Dipper arm: 8' 2"</b> <b>Shoe: 35"</b> <b>Counterweight: 13669 lb</b> <b>Without D/Blade</b>	30 ft	-	-	*21210	*21210	-	-	-	-	-	-	*20010	*20010	10.67
	25 ft	-	-	*18600	*18600	*19240	19160	-	-	-	-	*15220	13510	18.39
	20 ft	-	-	*16960	*16960	*19360	18920	*18910	11840	-	-	*13880	9620	22.56
	15 ft	-	-	-	-	*24540	17990	18560	11510	12890	8020	12820	7980	25.07
	10 ft	-	-	-	-	*27590	16660	17950	10970	12700	7850	11660	7200	26.40
	5 ft	-	-	-	-	27350	15570	17360	10450	12460	7630	11280	6920	26.74
	0 ft	-	-	-	-	26780	15090	16990	10120	12300	7490	11580	7070	26.11
	-5 ft	-	-	*22430	*22430	*23260	15060	16910	10050	-	-	12730	7750	24.44
	-10 ft	-	-	-	-	*16590	15360	*12220	10270	-	-	-	-	21.50
<b>Boom: 18' 10"</b> <b>Dipper arm: 9' 6"</b> <b>Shoe: 35"</b> <b>Counterweight: 13669 lb</b> <b>Without D/Blade</b>	30 ft	-	-	*17480	*17480	-	-	-	-	-	-	*13660	*13660	13.66
	25 ft	-	-	-	-	*15500	*15500	*11710	*11710	-	-	*10960	*10960	20.24
	20 ft	-	-	*13420	*13420	*15460	*15460	*15600	12000	-	-	*10060	8700	24.09
	15 ft	-	-	*20360	*20360	*19600	18280	*18370	11620	12990	8110	*9800	7340	26.46
	10 ft	-	-	-	-	*26720	16930	18060	11050	12740	7880	*9950	6670	27.72
	5 ft	-	-	-	-	27540	15710	17410	10480	12450	7620	*10490	6420	28.04
	0 ft	-	-	-	-	26780	15080	16970	10090	12240	7420	10730	6540	27.44
	-5 ft	-	-	*21470	*21470	*24610	14940	16810	9950	12210	7390	11670	7090	25.86
	-10 ft	-	-	-	-	*18670	15140	*14080	10080	-	-	*10180	8390	23.10
<b>Boom: 18' 10"</b> <b>Dipper arm: 8' 2"</b> <b>Shoe: 35"</b> <b>Counterweight: 13669 lb</b> <b>D/Blade Down</b>	30 ft	-	-	*21210	*21210	-	-	-	-	-	-	*20010	*20010	10.67
	25 ft	-	-	*18600	*18600	*19240	*19240	-	-	-	-	*15220	*15220	18.39
	20 ft	-	-	*16960	*16960	*19360	*19360	*18910	13600	-	-	*13880	11100	22.56
	15 ft	-	-	-	-	*24540	20760	*19650	13260	*13970	9300	*13550	9250	25.07
	10 ft	-	-	-	-	*27590	19400	*20770	12710	*16850	9120	*13830	8380	26.40
	5 ft	-	-	-	-	*28950	18270	*21340	12180	*16680	8900	*14690	8080	26.74
	0 ft	-	-	-	-	*27350	17780	*20580	11850	*15500	8750	*14220	8270	26.11
	-5 ft	-	-	*22430	*22430	*23260	17750	*17900	11770	-	-	*12780	9050	24.44
	-10 ft	-	-	-	-	*16590	*16590	*12220	12000	-	-	-	-	21.50
<b>Boom: 18' 10"</b> <b>Dipper arm: 9' 6"</b> <b>Shoe: 35"</b> <b>Counterweight: 13669 lb</b> <b>D/Blade Down</b>	30 ft	-	-	*17480	*17480	-	-	-	-	-	-	*13660	*13660	13.66
	25 ft	-	-	-	-	*15500	*15500	*11710	*11710	-	-	*10960	*10960	20.24
	20 ft	-	-	*13420	*13420	*15460	*15460	*15600	13760	-	-	*10060	10040	24.09
	15 ft	-	-	*20360	*20360	*19600	*19600	*18370	13380	*14110	9390	*9800	8520	26.46
	10 ft	-	-	-	-	*26720	19670	*20310	12800	*16630	9150	*9950	7780	27.72
	5 ft	-	-	-	-	*28760	18420	*21180	12220	*16710	8880	*10490	7510	28.04
	0 ft	-	-	-	-	*28000	17770	*20840	11820	*15970	8690	*11530	7660	27.44
	-5 ft	-	-	*21470	*21470	*24610	17620	*18720	11670	*13530	8660	*12350	8300	25.86
	-10 ft	-	-	-	-	*18670	17840	*14080	11800	-	-	*10180	9800	23.10

: Along undercarriage, : Across undercarriage, H : Lifting hook related to ground level

1. Machine in "Fine Mode-F" (Power Boost), for lifting capacities.
2. The above loads are in compliance with SAE and ISO Hydraulic Excavator Lift Capacity Standards.
3. Rated loads do not exceed 87% of hydraulic lifting capacity or 75% of tipping load.
4. Rated loads marked with an asterisk ( \* ) are limited by hydraulic capacity rather than tipping load.



394 Specifications  
Service history

## Service history

Service 500 hours		Type of service	Signature and stamp
Date	Hours	<input type="checkbox"/> First 500 hours <input type="checkbox"/> Service and maintenance	
Service 1000 hours		Type of service	Signature and stamp
Date	Hours	<input type="checkbox"/> Service and maintenance	
Service 1500 hours		Type of service	Signature and stamp
Date	Hours	<input type="checkbox"/> Service and maintenance	
Service 2000 hours		Type of service	Signature and stamp
Date	Hours	<input type="checkbox"/> Service and maintenance	
Service 2500 hours		Type of service	Signature and stamp
Date	Hours	<input type="checkbox"/> Service and maintenance	
Service 3000 hours		Type of service	Signature and stamp
Date	Hours	<input type="checkbox"/> Service and maintenance	
Service 3500 hours		Type of service	Signature and stamp
Date	Hours	<input type="checkbox"/> Service and maintenance	
Service 4000 hours		Type of service	Signature and stamp
Date	Hours	<input type="checkbox"/> Service and maintenance	
Service 4500 hours		Type of service	Signature and stamp
Date	Hours	<input type="checkbox"/> Service and maintenance	



Specifications  
**Service history**     **395**

Service 5000 hours		Type of service <input type="checkbox"/> Service and maintenance	Signature and stamp
Date	Hours		
Service 5500 hours		Type of service <input type="checkbox"/> Service and maintenance	Signature and stamp
Date	Hours		
Service 6000 hours		Type of service <input type="checkbox"/> Service and maintenance	Signature and stamp
Date	Hours		
Service 6500 hours		Type of service <input type="checkbox"/> Service and maintenance	Signature and stamp
Date	Hours		
Service 7000 hours		Type of service <input type="checkbox"/> Service and maintenance	Signature and stamp
Date	Hours		
Service 7500 hours		Type of service <input type="checkbox"/> Service and maintenance	Signature and stamp
Date	Hours		
Service 8000 hours		Type of service <input type="checkbox"/> Service and maintenance	Signature and stamp
Date	Hours		
Service 8500 hours		Type of service <input type="checkbox"/> Service and maintenance	Signature and stamp
Date	Hours		
Service 9000 hours		Type of service <input type="checkbox"/> Service and maintenance	Signature and stamp
Date	Hours		



**396**      Specifications  
**Service history**

Service 9500 hours		Type of service <input type="checkbox"/> Service and maintenance	Signature and stamp
Date	Hours		
Service 10000 hours		Type of service <input type="checkbox"/> Service and maintenance	Signature and stamp
Date	Hours		
Service 10500 hours		Type of service <input type="checkbox"/> Service and maintenance	Signature and stamp
Date	Hours		
Service 11000 hours		Type of service <input type="checkbox"/> Service and maintenance	Signature and stamp
Date	Hours		
Service 11500 hours		Type of service <input type="checkbox"/> Service and maintenance	Signature and stamp
Date	Hours		
Service 12000 hours		Type of service <input type="checkbox"/> Service and maintenance	Signature and stamp
Date	Hours		



## Alphabetical index

### A

Accidents.....	168
Accumulator, emergency operation.....	333
Accumulator, handling.....	333
Accumulator, pressure releasing.....	334
AdBlue®/DEF.....	351
AdBlue®/DEF information.....	10
AdBlue®/DEF tank, draining.....	314
AdBlue®/DEF, filling.....	312
Air conditioning filter, cleaning and replacing.....	298, 306
Air conditioning filter, cleaning and replacing.....	298, 306
Alarm texts.....	66
Alternative fuels.....	345
Arrival Inspection.....	277
Attachment quick coupler.....	221, 230
Attachment quick coupler.....	221, 230
Attachments.....	219
Attachments, connecting and disconnecting.....	221
Audio system.....	126
Auxiliary heater.....	135, 144
Auxiliary heater.....	135, 144

### B

Batteries.....	274
Batteries, charging.....	316
Battery condition, check.....	302
Battery disconnect switch.....	264
Before service, read.....	261
Boom and dipper arm.....	373
Boom float position, description.....	219
Bucket teeth, replacing.....	328, 330
Bucket teeth, replacing.....	328, 330
Buckets.....	237

### C

Cab.....	13, 107, 360
Cab.....	13, 107, 360
Cab.....	13, 107, 360
Carbon dioxide emissions.....	356
CareTrack.....	18
CareTrack with anti-theft.....	70
CE-marking, EMC-directive.....	20
Change capacities.....	353
Change intervals.....	354
Cleaning engine compartment.....	320
Cleaning machine.....	318
Climate control system.....	117
Communication equipment, installation..	23
Control lockout system.....	111
Control types for X1 and X3 operation....	79

Controls.....	96
Coolant.....	307, 342
Coolant.....	307, 342
Coolant level, checking.....	325

### D

Delivery Inspection.....	277
Delivery Instructions.....	277
Demolition work.....	217
Digging forces.....	378
Dimensions.....	370
Display unit.....	44
Door.....	121

### E

Electrical distribution box.....	264
Electrical system.....	12, 357
Electrical system.....	12, 357
Emergency exit.....	125
Emission compliance.....	187
Engine.....	9, 356
Engine.....	9, 356
Engine air cleaner.....	321
Engine air cleaner cover, cleaning.....	325
Engine air cleaner primary filter, cleaning and replacing.....	321
Engine air cleaner primary filter, replacing.....	306
Engine air cleaner secondary filter, replacing.....	309, 324
Engine air cleaner secondary filter, replacing.....	309, 324
Engine block heater.....	174
Engine oil.....	341
Engine oil level, checking.....	289, 310
Engine oil level, checking.....	289, 310
Engine, specifications.....	356
Entering, leaving and climbing the machine.....	267
Entering, leaving and climbing the machine.....	267
Environmental requirements.....	9
Equipment.....	17
Excavator unit, greasing.....	288, 294
Excavator unit, greasing.....	288, 294
Exhaust aftertreatment system.....	11, 180
Exhaust aftertreatment system.....	11, 180
Exhaust aftertreatment system, alarms requiring special actions.....	188

### F

Fire extinguisher, location.....	125
Fire prevention.....	268
Fuel.....	345
Fuel system.....	345
Fuel system, bleeding.....	315



Alphabetical index

398

Fuel, filling.....	310	Measures before operating.....	171
<b>G</b>		<b>O</b>	
Grease.....	344	Operating.....	179
Ground pressure.....	366	Operating on public roads.....	170
<b>H</b>		Operator comfort.....	112
Hammer.....	239	Operator obligations.....	166
Hammer (hydraulic breaker).....	239	Operator safety.....	168
Handling hazardous materials.....	271	Operator seat.....	112
Handling line, tubes and hoses.....	276	Operator's manual, storage.....	124
High voltage overhead power line.....	208	Overload warning.....	254, 304
Hose rupture valves.....	246	Overload warning.....	254, 304
Hour meter.....	123	<b>P</b>	
Hydraulic oil.....	266, 343	Paint finish maintenance.....	319
Hydraulic oil.....	266, 343	Parking.....	193
Hydraulic oil level, checking.....	290	Product plates.....	25
Hydraulic system.....	15, 265, 362	<b>R</b>	
Hydraulic system.....	15, 265, 362	Radiator and coolers, cleaning.....	300, 325
Hydraulic system.....	15, 265, 362	Radiator and coolers, cleaning.....	300, 325
Hydraulic system, releasing pressure...	332	Rain shield.....	122
Hydraulic system, warming up.....	177	Recommended bucket sizes.....	376
<b>I</b>		Recommended intervals for critical	
Information and warning decals.....	27	parts.....	335
Instrument panel, front.....	38	Recommended lubricants.....	338
Instrument panel, left.....	36	Recommended lubricants.....	338
Instrument panel, rear.....	94	Refrigerant.....	275, 361
Instrument panel, right.....	80	Refrigerant.....	275, 361
Intended use.....	9	Regeneration.....	180
<b>L</b>		Retrieving and towing.....	195
Lifting capacities.....	380	Reversible fan.....	218
Lifting machine.....	201	Roof.....	123
Lifting objects.....	250	Rules for digging.....	205
Logged machine data.....	18	Running-in instructions.....	160
Lubrication.....	279	<b>S</b>	
Lubrication and service chart 277, 279, 281		Safety components.....	24
Lubrication and service chart 277, 279, 281		Safety rules when operating.....	166
Lubrication and service chart 277, 279, 281		Seat belt.....	116
<b>M</b>		Selecting track shoes.....	248
Machine view.....	19	Service capacities and change intervals	353
Machine weights.....	364	Service history.....	277, 394
Maintenance service, every 10 hours...	287	Service history.....	277, 394
Maintenance service, every 1000 hours	303	Service position.....	260
Maintenance service, every 2000 hours	306	Service Programme.....	278
Maintenance service, every 250 hours.	296	Signalling diagram.....	256
Maintenance service, every 4000 hours	309	Starting engine.....	172
Maintenance service, every 50 hours...	289	Starting engine in cold weather.....	173
Maintenance service, every 500 hours.	300	Starting with booster batteries.....	175
Maintenance service, when required...	310	Stopping.....	192
Maintenance under special		Storage compartment.....	123
environmental conditions.....	336	Sun shade.....	122
Measurements before transporting		Sun shield.....	122
machine.....	197	Swing bath, grease checking.....	304
		Swing drive unit.....	296





---

Swing drive unit, checking oil level.....	297
Swing gear bearing, greasing.....	298
Symbol key.....	280
<b>T</b>	
Touch-up painting.....	319
Track drive unit.....	303
Track drive unit, checking oil level.....	304
Track unit, adjusting tension.....	327
Track unit, checking shoe screws.....	287
Track unit, checking tension.....	292
Transporting machine.....	197
Tying down machine.....	199
<b>U</b>	
Underground cables and pipes.....	212
<b>V</b>	
Visibility.....	161
Vision system.....	130
Volvo Smart View.....	132
<b>W</b>	
Warming up.....	176
Washer reservoir.....	288
Water separator, draining.....	314
Welding.....	317
Whole-body vibrations.....	203
Windows.....	120
Working in cold weather.....	216
Working in water and on boggy ground	215
Working on slopes.....	213
Working ranges.....	374
Working with buckets.....	238
Working with long range attachments...	245
Working within dangerous areas.....	208



A series of horizontal dotted lines for writing, consisting of 20 lines.



A series of horizontal dotted lines for writing, consisting of 20 lines spaced evenly down the page.



Alphabetical index

402

---